

BAUMALIGHT™



BAUMALIGHT™

**BRUSH CUTT
CSC744 And CSC760 CUTTER
OPERATOR'S MANUAL**

Issue Date: Jan 2018

TABLE OF CONTENTS

1 INTRODUCTION	1
1.1 Overview.....	1
1.2 Intended Use And Foreseeable Misuse	1
2 SAFETY	2
2.1 Safety Alert Symbol And Safety Words	2
2.2 Operational Hazards.....	2
Prepare for Emergencies	3
Replace Safety Signs	3
Do Not Allow Riders	3
Lower Operating Speed	4
Avoid Rollover	4
Avoid Powerlines & Underground Utilities	4
Detach Cutter Safely.....	4
Hazards From Modifying Equipment	4
2.3 Maintenance Hazards.....	5
3 SAFETY SIGNS	6
4 OPERATION	8
4.1 Preparation For Use	8
4.2 Hydraulic Connections	8
4.3 Machine Components	9
4.4 Attach Brush Cutter.....	9
4.5 Transporting.....	10
4.6 First Time User Tips	10
4.7 Field Operation	11
4.8 Detach Brush Cutter.....	13
5 SERVICE AND MAINTENANCE	14
5.1 Daily	14
5.2 First Hour Of Use.....	14
5.3 Every Four Hours	14
5.4 Replace Cutting Teeth.....	15
700 Series Teeth.....	15
500 Series Teeth (Optional).....	15
6 TROUBLESHOOTING	16
7 WARRANTY	17

1 INTRODUCTION

1.1 Overview

Congratulations on your choice of a Baumalight Brush Cutt to complement your brush cutting operation. This equipment has been designed and manufactured to meet the needs of a discriminating buyer for efficient brush cutting.

The unique rotor design reduces the brush to mulch. Controlling the brush cutter is done completely from the skid steer providing the ability for precise control and operator comfort.

Skid steer must have suitable safety equipment properly installed.

Safe, efficient and trouble free operation of your Brush Cutt requires that you and anyone else who will be operating or maintaining the Brush Cutt, read and understand the Safety, Operation, Maintenance and Troubleshooting information contained within the Operator's Manual.

This manual covers the Baumalight CSC744 and CSC760 Brush Cutt. Use the Table of Contents as a guide to locate required information.

Keep this manual handy for frequent reference and to pass on to new operators or owners. Call your Baumalight dealer, distributor or the factory if you need assistance, information or additional copies of the manuals.

OPERATOR ORIENTATION - The directions left, right, front and rear, as mentioned throughout this manual, are as seen from the driver's seat and facing in the direction of travel.

1.2 Intended Use And Foreseeable Misuse

The cutter is designed to be used by an experienced operator. Operator must be trained in the safe operation of a skid steer and hazards related to using the brush cutter and the safe use of the brush cutter for the intended purpose. Operators will require personal protective equipment to reduce the risk from some hazards that cannot be completely eliminated or controlled by the design of the cutter.

Care is required to ensure that the brush cutter will not come in contact with metallic objects, stones or other materials.

Brush cutters are not designed for use in hazardous atmospheres where there is a risk of fire or explosion due to flammable gases or vapors. Use in hazardous, explosive atmospheres is prohibited. Serious injury or death of the operator or bystanders may be caused if cutter is misused. Misuse may also cause damage to the machine carrying the cutter.

2 SAFETY

2.1 Safety Alert Symbol And Safety Words

You must read, understand and follow the instructions given by the skid steer manufacturers, as well as the instructions in this manual.

The safety information in this manual is denoted by the safety alert symbol:



This symbol means ATTENTION! BECOME ALERT! YOUR SAFETY IS INVOLVED!

The level of risk is indicated by the following signal words:

⚠ DANGER
DANGER - Indicates a hazardous situation, which, if not avoided, WILL result in death or serious injury.

⚠ WARNING
WARNING - Indicates a hazardous situation, which, if not avoided, could result in death or serious injury.

⚠ CAUTION
CAUTION - Indicates a hazardous situation, which, if not avoided, could result in minor or moderate injury.

NOTICE
NOTICE - Indicates a situation that could result in damage to the equipment or other property.

2.2 Operational Hazards

⚠ WARNING
Prevent death or serious injury.
Read and understand this manual before operating cutter.
Always stop engine and remove key before leaving operators seat.
Never allow anyone near the cutter during operation.
Travel at a safe speed.

⚠ WARNING
Prevent death or serious injury from moving parts.
Moving parts can crush and dismember.
Do not operate without guards and shields in place.
Disconnect and lockout power source before adjusting or servicing.

⚠ WARNING
Use cutter only for the designed applications.
Any other use may result in personal injury, damage to equipment and may void the warranty.

⚠ WARNING

Prevent death or serious injury.

Verify cutter is locked to skid steer before operation or transport.

⚠ WARNING

Protect from flying debris.

Wear proper safety glasses, goggles, or a face shield to protect from flying debris.

Carefully read all safety messages in this manual and on equipment safety signs. Keep safety signs in good condition and replace missing or damaged safety signs.

New equipment components and repair parts must include the current safety decal.

Learn how to properly operate equipment. NEVER operate or work around this equipment without proper instruction, while fatigued or under the influence of alcohol, prescription or non-prescription medication or if feeling ill.

Keep your equipment in proper working condition. Know the regulations and laws that apply to you and your industry. This manual is not to replace any regulations or laws. Additional information may be found at: www.asae.org or www.osha.gov. If you do not understand any part of this manual, contact Baumalight at 866-820-7603.

Prepare for Emergencies

- Be prepared in case of emergencies.
- Keep a fire extinguisher and first aid kit close to the machine.
- Keep emergency phone numbers close to your phone.
- Know your address so emergency services can locate you if an emergency arises.

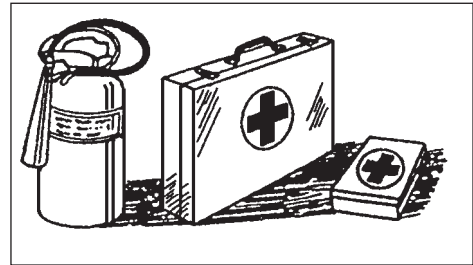

Replace Safety Signs

- Replace missing or damaged safety signs.
- Safety signs are identified in Section 3 of this manual.
- Replacement safety signs are available from your Baumalight dealer.

Do Not Allow Riders

- NEVER lift or carry anyone on cutter.
- NEVER use cutter as a work platform.
- NEVER allow passengers on cutter.

Lower Operating Speed

Keep cutter low and move at slow speeds on rough or uneven terrain.

Lower operating speed while operating in heavy conditions.

Avoid Rollover

The equipment may rollover, resulting in death or serious injury. To help prevent rollover:

- Travel at a slow speed.
- Avoid sharp turns & sudden movement on slopes.
- Carry cutter close to the ground.
- Avoid holes, ditches and other obstructions which may cause equipment to rollover.
- Balance load so weight is evenly distributed and load is stable.
- Use caution when operating on slopes and do not operate on excessively steep slopes.
- Do not exceed load capacity of equipment.

Avoid Powerlines & Underground Utilities

DANGER

Prevent electrocution.

Death or serious injury can result if equipment comes near or contacts power lines.

Electrocution can occur without direct contact.

- Check clearance before raising equipment.
- Have local utilities locate and mark under ground wires, cables, pipelines and other hazards before operation.

DO NOT leave the operator's seat if any part of the equipment contacts electric lines or cables.

Detach Cutter Safely

Detach cutter on a firm and level surface. Be sure people, livestock and pets are clear of machinery.

Raised Attachment

WARNING

Crushing hazard.

Raised, unsupported cutter can fall, resulting in death or serious injury.

Never enter the area under a raised cutter.

A raised cutter can lower unexpectedly, resulting in death or serious injury.

NEVER enter area under a raised cutter.

Lower cutter to ground, engage parking brake, shut off engine and remove key before servicing.

Hazards From Modifying Equipment

Do not make any alterations to your cutter. Altering may cause your equipment to be unsafe and may void the manufacturers' warranty.

Avoid Loud Noise

WARNING

Prolonged exposure to loud noise can cause impairment or loss of hearing.

Wear a suitable hearing protective device such as earmuffs or earplugs to protect against objectionable or uncomfortable loud noises.

Stay Clear Of Moving Parts

WARNING

Moving parts can cause serious injury or death.

Keep shields and guards in place at all times. **DO NOT** operate without shields and guards.

DO NOT wear loose fitting clothing.

Avoid Wood Dust Inhalation

WARNING

Wear an approved respirator (N95 Type as a minimum).

Follow local, state and federal regulations.

The health effects from exposure to wood dust are due to chemicals in the wood or chemical substances in the wood created by bacteria, fungi, or molds.

2.3 Maintenance Hazards

Before servicing, park machine on a firm and level surface, set parking brake and place a "Do Not Operate" tag on control panel. Read and understand this manual. If you do not understand any part of the manual, contact Baumalight at 866-820-7603.

Always wear face and/or eye protection, safety shoes, and other protective equipment appropriate for the job.

Do not make unauthorized modifications. Contact Baumalight at 866-820-7603. Before you weld, cut/drill holes, or make any other modifications.

Always use Baumalight replacement parts.

3 SAFETY SIGNS

WARNING

Moving parts can entangle and cut.

Keep clear of moving parts.

Follow lockout procedure before servicing.

WARNING

Crushing hazard.

Before performing inspections, service or maintenance:

Park machine on firm, level surface.

Engage parking brake.

Turn engine off and remove key.

Place "Do Not Operate" tag on control panel.

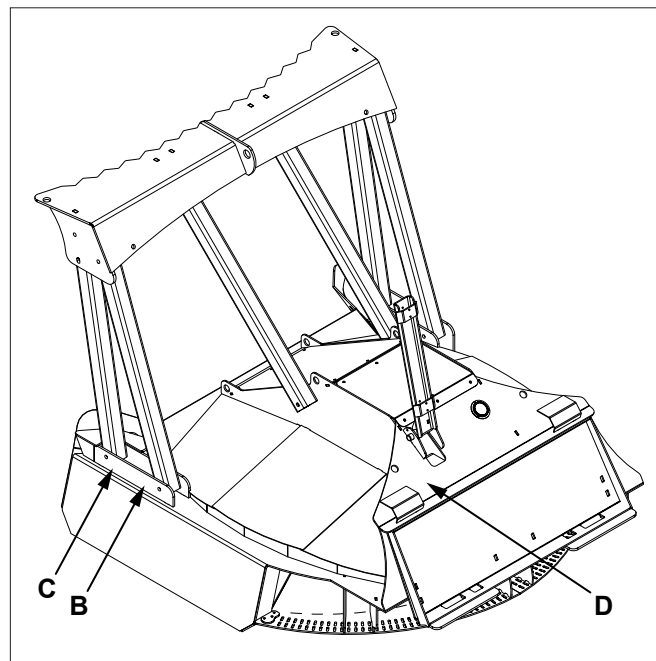
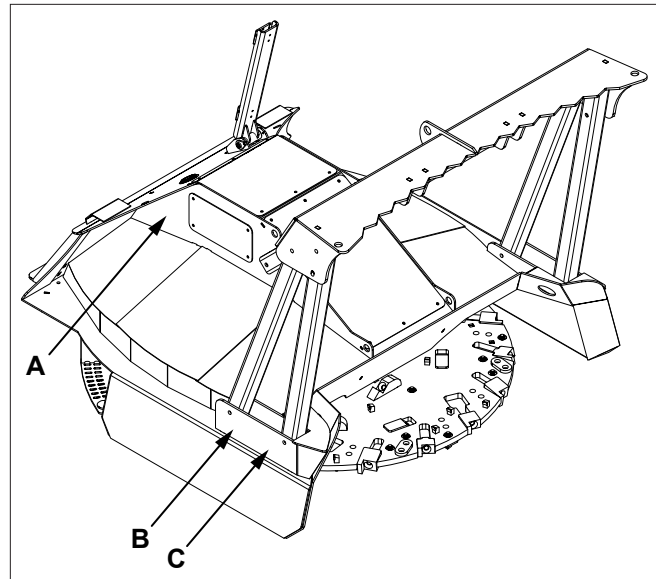

A. MTB-175 Safety Sign

CAUTION

- Read and understand the operator's manual before starting. Review safety instructions annually.
- Do not permit rider on the carrier or equipment. Never carry children on the machine.
- Do not allow children to operate the equipment.
- Operate only with guards installed and in good condition.
- Keep away from moving parts.
- Before operating, clear debris away from production area.
- Do not operate in unsafe position.
- Turn machine off, lower machine to ground, stop engine, set park brake, remove ignition key and wait for all moving parts to stop before servicing, repairing, adjusting or unplugging.
- Support equipment securely before working beneath unit.
- Wear Personal Protective Equipment (PPE) including but not limited to hard hat, safety shoes with slip resistant soles, safety goggles or face shield and hearing protection whenever operating equipment.
- Transport with clean reflectors, SMV and working lights as required by federal, provincial and local laws.

MTB-175

B. MTB-176 Safety Sign

DANGER

ROTATING BLADES - KEEP AWAY

To prevent serious injury or death:

- Never allow riders; especially children on carrier or cutter.
- Do not operate with bystanders in cutting area.
- Do not operate with deflectors or guards removed.
- Do not place hands or feet near intake or under shield.

MTB-176

C. MTB-177 Safety Sign

DANGER

THROWN OBJECT HAZARD

To prevent serious injury or death:

- Do not operate unless all guards are installed.
- Stop blade rotation if bystanders come within several hundred feet of machine.

MTB-177

D. MTB-182 Safety Sign

WARNING

HIGH PRESSURE FLUID HAZARD

To prevent serious injury or death from high pressure fluid:

- Relieve pressure on system before repairing or adjusting.
- Wear proper head and eye protection when searching for leaks. Use wood or cardboard instead of hands.
- Keep all components in good repair.

MTB-182

4 OPERATION

4.1 Preparation For Use

Although the cutter has been carefully inspected and checked prior to shipment from manufacturer, it is recommended that the unit be thoroughly inspected.

Check all bolts for tightness and remove all shipping tags, bags, skids, and blocking.

Remove any masking materials affixed during painting. Inspect equipment to verify that nameplates and all safety warning, caution signs and decals provided with the equipment are in place and clearly visible.

Visually inspect the cutter before each start up. Check for loose or missing parts and any damage that may have occurred during moving or shipping.

Review all skid steer pre-start instructions, and verify that all recommended steps and procedures have been followed.

Be sure you have the correct cutting teeth installed for the operation. The standard 700 series ripper teeth are for general mulching where rocks may be present. The optional 500 series planer teeth will provide a finer mulch, but are not to be used where rocks may be present.

4.2 Hydraulic Connections

WARNING

Pressurized fluids can penetrate the skin.

Disconnect and lock out power source before disconnecting and/or connecting hydraulic hoses.

The cutter is equipped with three hoses. You must connect the pressure, return and case drain hoses from cutter to skid steer hydraulic couplers.

Identify the pressure port hose and connect your hoses to the mulcher hoses. Skid steer hoses must be the same size as the mulcher hoses. Using smaller diameter hoses will decrease hydraulic flow.

Motor pressure port is B port on block (A port on motor).

Maximum allowable case pressure is 100 psi, case drain is required.

4.3 Machine Components

- A. Quick Attach
- B. Hydraulic Pressure Gauge
- C. Hydraulic Hose Holder
- D. Hydraulic Motor
- E. Push Bar
- F. Rotor
- G. Standard 700 Series Cutting Tooth
- H. Optional 500 Series Cutting Tooth

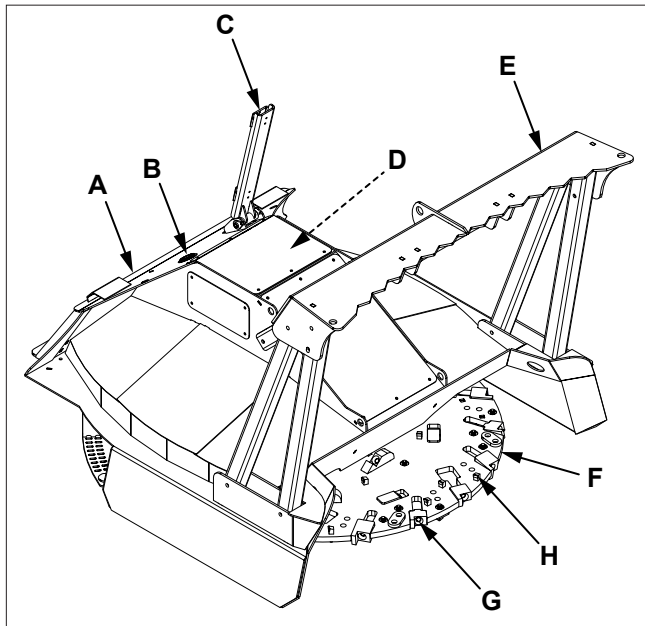

4.4 Attach Brush Cutter

⚠ WARNING

To prevent injury or machine damage put transmission in park.

Never position yourself between skid steer and cutter.

Only experienced and properly trained operator may operate skid steer and cutter.

1. Read and follow all safety instructions.
2. Attach skid steer to cutter. See skid steer operator's manual.
3. Connect hydraulic hoses. Verify hydraulic hoses are clear of pinch areas and moving parts.
4. Move to a clear open area to test functions.

4.5 Transporting

1. Verify all reflectors and Slow Moving Vehicle (SMV) sign are visible.
2. Verify hydraulics to cutter are disengaged.
3. Raise cutter slightly off the ground.
4. Travel at a reasonable and safe speed.

4.6 First Time User Tips

Operate all functions in a clear area low speed to get a good feel for the controls before you actually move into any brush.

Choose low density brush and move into it slowly, do not expect to get the first area done fast.

Operate with cutter slightly raised until you have a better feel how much the unit can take.

Use push bar to push brush or small trees over and allow cutter teeth to contact lower portion of brush and mulch it or cut it off. The rest of the plant will be mulched as the machine moves through the working area.

Each operator must experiment to find a technique that works for them in their application.

Although it is best to mulch when it is dry, the machine works well in wet conditions. However, you must travel slower to do the same quality mulching. It will also be necessary to clean the machine more frequently to prevent clogging.

WARNING

Always stop engine and remove key before leaving operators seat.

4.7 Field Operation

⚠ WARNING

Prevent serious injury or death caused by unexpected movement:

1. Park on a level surface.
2. Lower cutter to ground.
3. Engage parking brake.
4. Shut off engine and remove key.

⚠ WARNING

Keep shields and guards in place at all times. Do not operate without shields and guards.

Do not wear loose fitting clothing.

⚠ WARNING

Never operate brush cutter when other people are in the vicinity.

Debris can be thrown from cutting area.

Do not allow riders.

⚠ WARNING

Clean machine thoroughly before service or maintenance procedures.

The health effects from exposure to wood dust are due to chemicals or chemical substances in the wood created by bacteria, fungi, or molds.

1. Inspect work area to verify there are no rocks, metal or other debris before cutting.
2. Attach cutter to skid steer.

⚠ WARNING

Prevent serious injury or death.

Skid steer must be equipped with a forestry guard to protect the operator.

3. Lower cutter so skid plates are close to, or on the ground.
4. Set engine speed to low idle and engage cutter.
5. Slowly increase engine speed to high idle.
6. Monitor pressure gauge (A) closely during startup and throughout the cutting process.

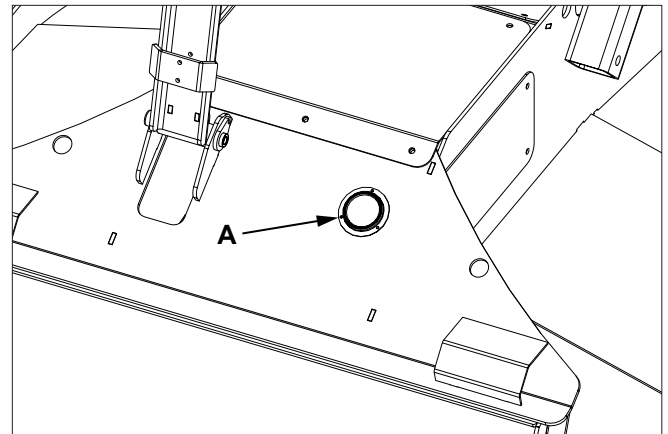

When first starting the cutter, hydraulic pressure on gauge (A) will jump from zero to maximum as the motor works to speed up the rotor. It can take up to thirty seconds for the rotor to reach operational speed. Do not attempt to use the cutter before operational speed is reached. The spinning momentum of the rotor provides the cutting power.

As operational speed is reached, pressure will drop to 2000 - 3000 psi. Monitor pressure gauge during operation. Maximum cutting performance is with hydraulic pressure between 2000 - 3000 psi.

7. Verify cutter is operating smoothly and start travel. When mulching standing brush, angle cutter up and away from cab. This will protect the operator and carrier from flying debris. The rotor should not be visible from the operator compartment. Attempting to mulch top-down by raising the rotor horizontally will result in the cutter throwing debris towards the operator.

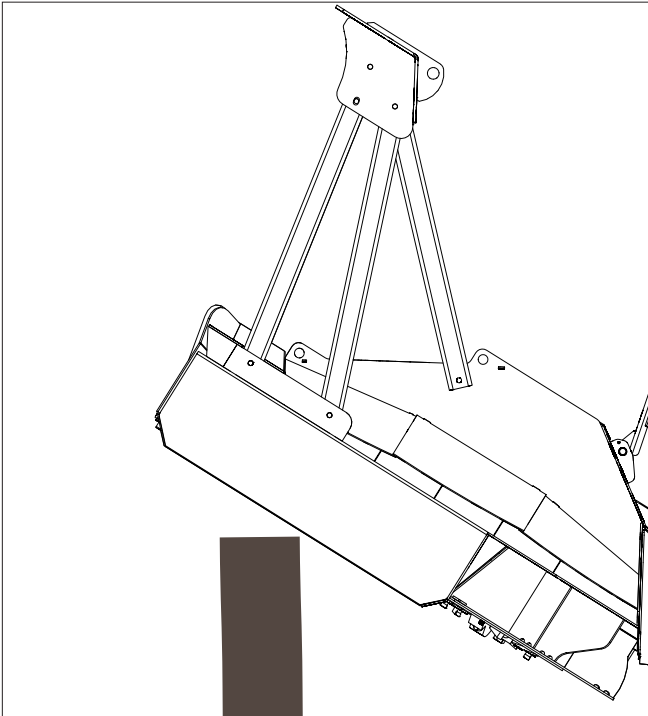

Correct Angle For Standing Brush

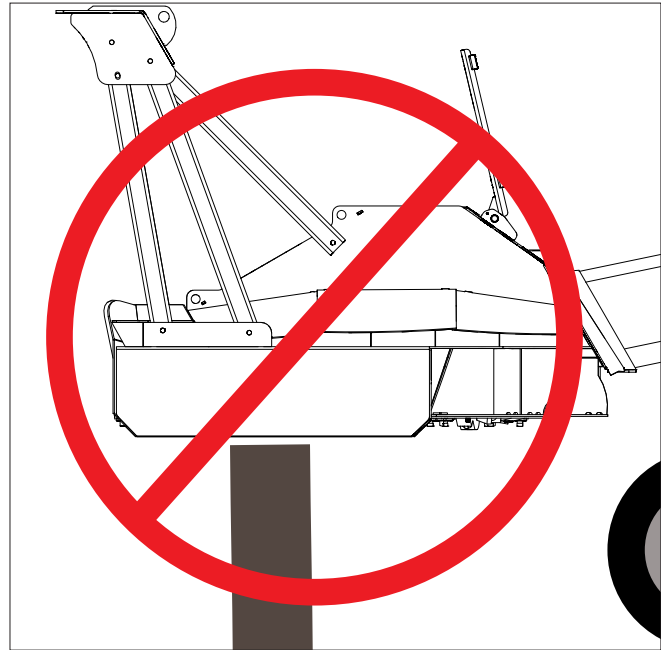

Incorrect Raised Position For Standing Brush

8. If cutter stalls, stop movement, slightly raise cutter and allow rotor to regain speed. Slow ground speed to prevent further stalling.

⚠ WARNING

Moving parts can crush and cut.

Keep clear of moving components.

Lockout skid steer before clearing jams.

9. Rotor will continue to spin freely when hydraulic power is disengaged. The rotor can be slowed by setting rotor against the soft ground and letting the friction stop the rotor. Do not set rotor on hard ground, stone or concrete. The cutter can be parked on the ground and the rotor will gradually slow to a stop.

4.8 Detach Brush Cutter

WARNING

Prevent death or serious injury caused by unexpected movement:

1. Park on a level surface.
 2. Lower cutter to ground.
 3. Engage parking brake.
 4. Shut off engine and remove key.
-
1. Park skid steer on a level surface.
 2. Lower cutter to the ground.
 3. Shut off engine and remove key.
 4. Disconnect hydraulic hoses.
 5. Detach skid steer from cutter. See skid steer Operator's Manual.

5 SERVICE AND MAINTENANCE

5.1 Daily

⚠ WARNING

Prevent serious injury or death caused by unexpected movement:

1. Park on a level surface.
2. Lower cutter to ground.
3. Engage parking brake.
4. Shut off engine and remove key.

Inspect the unit for buildup of dirt, mulch and debris. Clean out as needed.

5.2 First Hour Of Use

⚠ WARNING

Prevent serious injury or death caused by unexpected movement:

1. Park on a level surface.
2. Lower cutter to ground.
3. Engage parking brake.
4. Shut off engine and remove key.

The teeth bolts must be retighten every ten minutes for the first hour of use on a new cutter.

5.3 Every Four Hours

⚠ WARNING

Prevent serious injury or death caused by unexpected movement:

1. Park on a level surface.
2. Lower cutter to ground.
3. Engage parking brake.
4. Shut off engine and remove key.

Check cutting edge (A) of teeth for wear and damage. Keep cutting teeth in good condition. Unit will cut faster and remaining teeth will last longer if broken teeth are replaced.

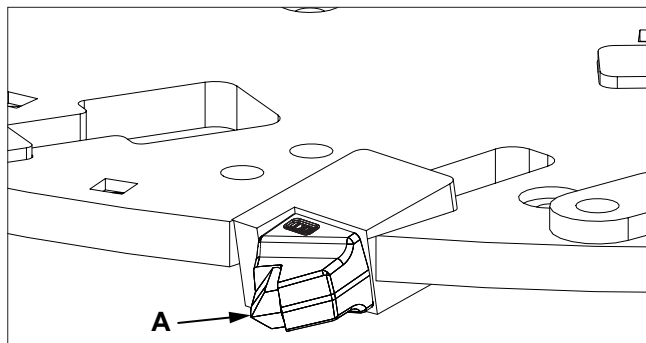

700 Series Teeth

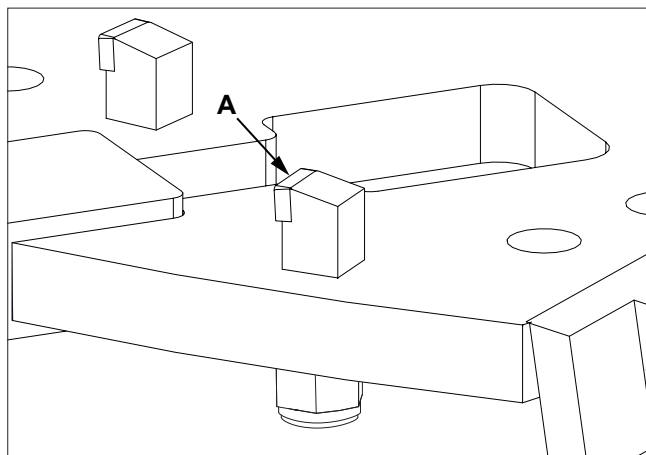

500 Series Teeth

5.4 Replace Cutting Teeth

700 Series Teeth

⚠ WARNING

Prevent serious injury or death caused by unexpected movement:

1. Park on a level surface.
2. Lower cutter to ground.
3. Engage parking brake.
4. Shut off engine and remove key.

1. Park skid steer and cutter on a level surface.
2. Lower cutter to the ground.
3. Shut off engine and remove key.
4. Inspect cutting teeth for damage and wear.
5. Replace individual teeth as needed.
6. Remove bolt and tooth (A). Install new tooth.
7. Install bolt and tighten to 170 lb/ft (230 Nm) of torque.

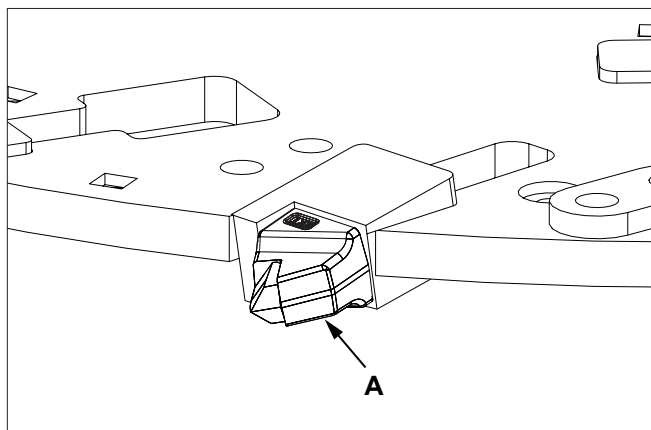

Note: Parts breakdown can be found on Baumalight's website. www.baumalight.com

500 Series Teeth (Optional)

⚠ WARNING

Prevent serious injury or death caused by unexpected movement:

1. Park on a level surface.
2. Lower cutter to ground.
3. Engage parking brake.
4. Shut off engine and remove key.

1. Park skid steer and cutter on a level surface.
2. Lower cutter to the ground.
3. Shut off engine and remove key.
4. Inspect cutting teeth for damage and wear.
5. Replace individual teeth as needed.
6. Remove locknut (A) and tooth (B). Install new tooth.
7. Tighten locknut (A) to 150 lb/ft (204 Nm) of torque.

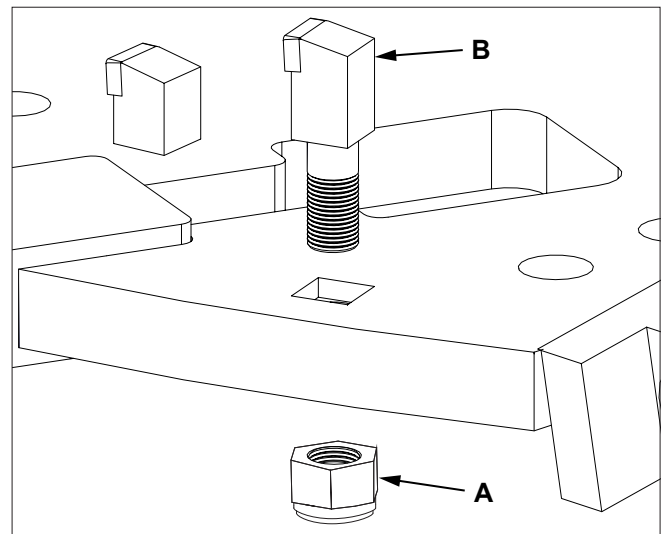

Note: Parts breakdown can be found on Baumalight's website. www.baumalight.com

6 TROUBLESHOOTING

PROBLEM	CHECK	SOLUTION
Rotor does not spin.	Rotor jammed.	Remove material from rotor / teeth.
	Verify hydraulic hoses are connected.	Connect hoses.
Skid steer is not able to lift cutter.	Skid steer is too small.	Use proper size skid steer.
Excessive vibration.	Cutting teeth worn or missing.	Replace worn, broken or missing cutting teeth.
	Debris packed on rotor / teeth.	Remove debris.

7 WARRANTY

This product is warranted to be free of defects in materials and workmanship under normal use and service, for a period of one year from the date of purchase, when operated and maintained in accordance with the Operating and Maintenance Instructions supplied with this unit. This warranty does not cover misuse or negligence.

Under no circumstances will the manufacturer be liable for any consequential damage or expense of any kind, including loss of profits. The manufacturer is under no circumstances liable for skid steer damage of any kind. The manufacturer is not liable for the maintenance of the product.

This warranty is extended only to the original purchaser. Warranty is void if repairs are attempted by anyone other than an Authorized Service Center.

If a difficulty develops with the product, you should contact your nearest Authorized Repair Center, or distributor. Only these locations are authorized to make repairs to the product or affect the replacement of defective parts, which will be done at no charge within a reasonable time after the receipt of the product. Units or parts should be returned at the customer's expense to the nearest repair location or Authorized Service Center. Pack unit in a strong carton and pad tightly to avoid damage. Damage in-transit is not covered by warranty. Include original purchase receipt with any claim (keeping a copy for your files).

The Manufacturer's Liability is limited to repair of the product and/or replacement of parts and is given to the purchaser in lieu of all other remedies including incidental and consequential charges. There are no warranties, expressed or implied other than those specified herein. For the nearest Authorized Service Center call the manufacturer.

Please note the following details and file this information in an appropriate place.

Model Number: _____ S/N: _____

Date of Purchase: _____ Owner's Name _____

MTB MFG INC.
CORPORATE HEADQUARTERS
4575 Powell Rd.,
Wallenstein, Ontario Canada
N0B 2S0
Phone - 519.698.9864
Toll Free - 866.820.7603
Fax - 519.698.1087
www.baumalight.com

