

BUFFALO TURBINE

180 Zoar Valley Road
Springville, NY 14141

TEL: 716 592 2700 FAX: 716 592 2460

EMAIL: info@buffaloturbine.com

WEBSITE: www.buffaloturbine.com

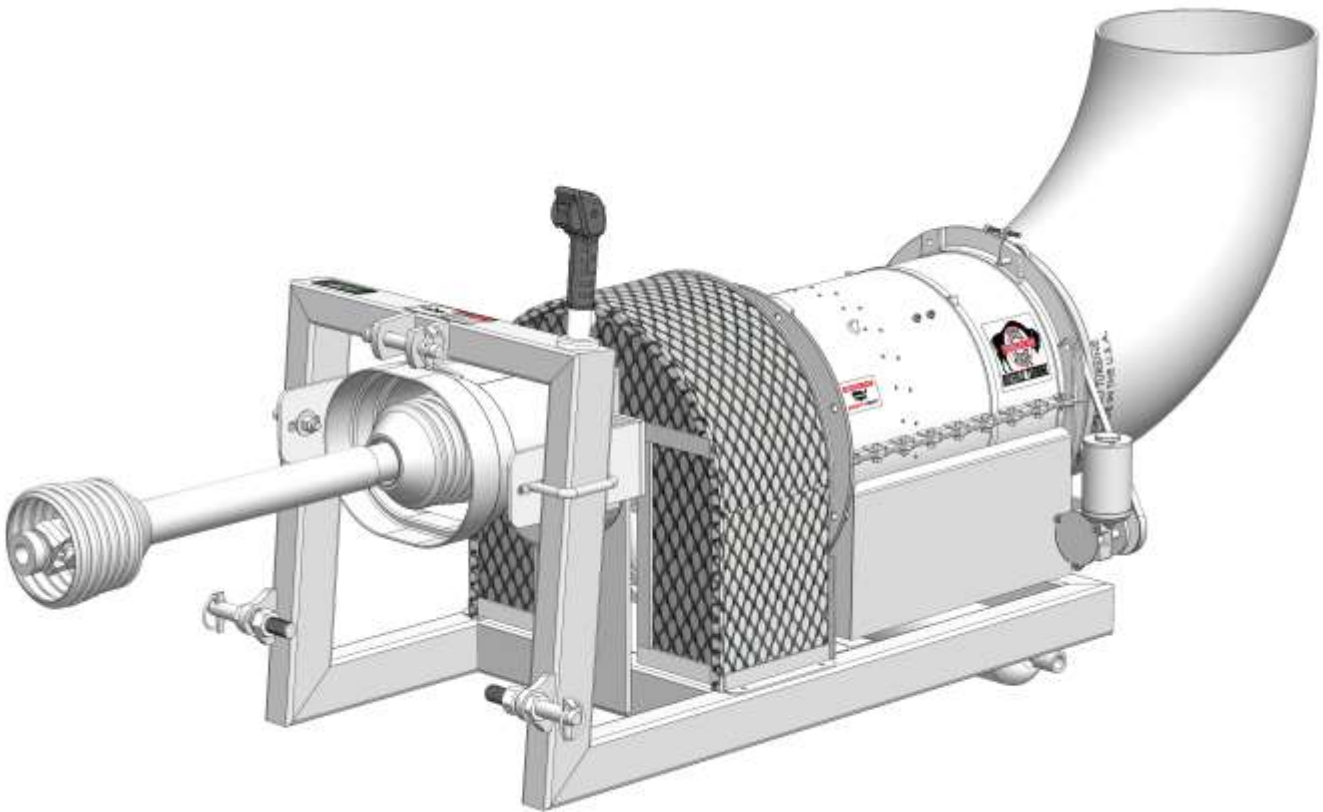

BUFFALO TURBINE'S BT-CPTOCE ORIGINAL INSTRUCTIONS AND PARTS MANUAL

TABLE OF CONTENTS

Ref. Number	Description	Page Number
1.0	Introduction	2
2.0	Safety	3
2.1	Safety Decals	4
2.2	General Safety	4
2.3	Operating Safety	4
2.4	Maintenance Safety	5
2.5	Transport Safety	5
2.6	Storage Safety	5
2.7	Sign-off Form	5
3.0	Warranty Information	6
3.1	Warranty Registration Form	7
4.0	Operations	8
4.1	To the new operator or owner	8
4.2	Break-in	8
4.3	Pre-Operation Checks	8
4.4	Attaching Blower to Tractor	9
4.5	Field Operation	9
4.6	Operating RPM	9
4.7	Storage	9
5.0	Troubleshooting	10
6.0	Machine Specification	10
7.0	Maintenance	11
7.1	Maintenance Safety	11
7.2	Fluids	11
7.3	Service Checklist	11
	Declaration of Conformity	12
	Moreflex Coupling Parts	13
	Moreflex Coupling Installation	14
	BT-CPTOCE Parts Reference (Before Serial # 29927)	15
	BT-CPTOCE Parts Reference (After Serial # 29927)	16
	BT-CPTOCE Parts Sub-Assemblies	17
	Wiring Schematic for Control Box	18
	Bill of Materials for BT-CPTOCE	19
	Gearbox Lubrication Information	20
	Nozzle Options	21
	Buffalo Turbine Additional Products	22

1.0 INTRODUCTION

Congratulations on your choice of a Buffalo Turbine Debris Blower. This equipment has been designed and manufactured to meet the needs of the Turf Care Industry.

Safe, efficient and trouble-free operation of your Buffalo Turbine Blower requires that you and anyone else, who will be operating or maintaining the Blower, read and understand all of the safety, operation, maintenance and troubleshooting information contained within this Operator's manual.

This Manual covers the BT-CPTOCE Turbine Blower.

Keep this manual handy for frequent reference and to pass on to new operators or owners. Call your Buffalo Turbine dealer or distributor if you need assistance, information, or additional copies of the manuals.

SERIAL NUMBER LOCATION

Always give your dealer the serial number of your Debris Blower when ordering parts or requesting service or other information.

The serial number plate(s) is located where indicated in the pictures below. Please document the number in the space provided for easy reference.

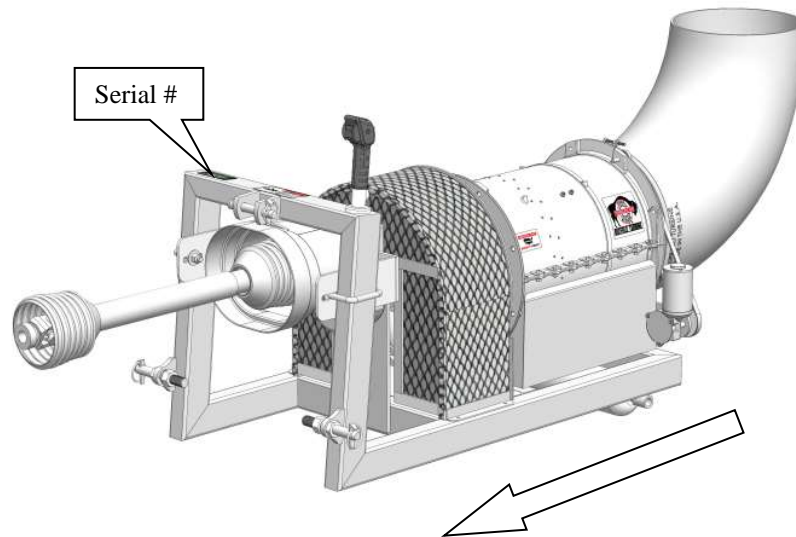

OPERATOR ORIENTATION – The directions left, right, front and rear, as mentioned throughout the manual, are as seen from the driver's seat and facing in the direction of travel.

MODEL BT-CPTOCE TOP SURFACE OF FRAME

Serial Number: _____

2.0 SAFETY

YOU are responsible for the **SAFE** operation and maintenance of your Buffalo Turbine Debris Blower. **YOU** must ensure that you and anyone else, who is going to operate, maintain or work around the Buffalo Turbine Blower be familiar with the operating and maintenance procedures and related **SAFETY** information contained in this manual. This manual will take you step-by-step through your working day and alerts you to all good safety practice while operating the Blower.

Remember **YOU** are the key to safety. Good safety practices not only protect you but also the people around you. Make these practices a working part of your safety program. Be certain that **EVERYONE** operating this machine is familiar with the procedures recommended and follows safety precautions. Remember most accidents can be prevented. Do not risk injury or death by ignoring good safety practices.

- Blower owners must give operating instructions to operators or employees before allowing them to operate the Blower, and at least annually thereafter.
- The most important safety device on this equipment is a **SAFE** operator. It is the operator's responsibility to read and understand ALL Safety and Operating instructions in the manual and to follow these. All accidents can be avoided.
- A person who has not read and understood all operating instructions is not qualified to operate the machine. An untrained operator exposes themselves and bystanders to possible serious injury or death.
- Do not modify the equipment in any way. Unauthorized modification may impair the function and/or safety which could affect the life of the equipment.
- Think **SAFETY!** Work **SAFELY!**

This Safety Alert symbol means **ATTENTION! BECOME ALERT! YOUR SAFETY IS INVOLVED!**

The Safety Alert symbol identifies important safety messages on the Buffalo Turbine Blower and in the manual. When you see this symbol, be alert to the possibility of personal injury or death. Follow the instructions in the safety message.

Why is **SAFETY** important to you?



**3 Big Reasons: Accidents Disable and Kill
Accidents Cost
Accidents Can Be Avoided**

SIGNAL WORDS: Note the use of the signal words **DANGER**, **WARNING** and **CAUTION** with the safety messages. The appropriate signal word for each message has been selected using the following guidelines

1. **DANGER** –injury or death if the proper precautions are not taken.
2. **WARNING** -- A specific hazard or unsafe practice that **COULD** result in severe personal injury or death if proper precautions are not taken.
3. **CAUTION** – Unsafe practices that **COULD** result in personal injury if proper practices are not taken, or as a reminder of good safety.

The Safety Alert symbol identifies important safety messages on the Buffalo Turbine Blower and in the manual. When you see this symbol, be alert to the possibility of personal injury or death. Follow the instructions in the safety message.

2.1 SAFETY DECALS

The types of decals on the blower unit are shown below. Good safety requires that you familiarize yourself with the various Safety Decals, the type of warning and the area, or particular function related to that area that requires your **SAFETY AWARENESS.* THINK SAFETY! WORK SAFELY!**

!ATTENTION!

1. **KEEP HANDS, FEET AND CLOTHING AWAY FROM POWER DRIVEN PARTS.**
2. **STOP ENGINE AND REMOVE KEY BEFORE LEAVING OPERATOR'S POSITION.**
3. **MACHINE MUST COME TO A COMPLETE STOP BEFORE ANY MAINTENANCE, TO INCLUDE ADJUSTING, LUBRICATING OR CLEANING, IS PERFORMED.**
4. **KEEP PEOPLE AND PETS AT SAFE DISTANCE FROM MACHINE.**
5. **KEEP ALL GUARDS AND SHIELDS IN PLACE.**

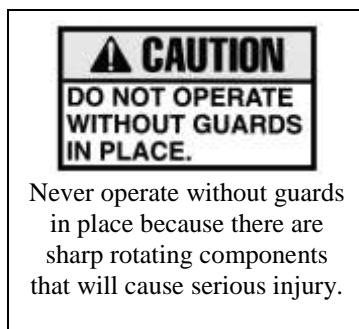
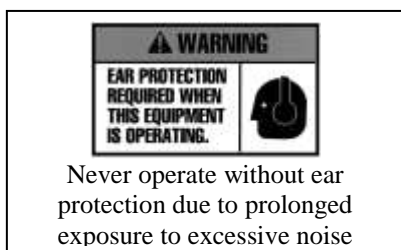
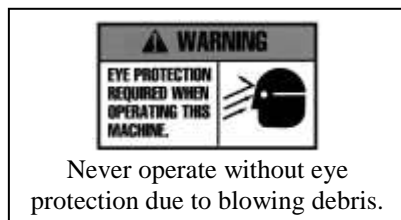

REMEMBER – If safety decals have been damaged, removed, become illegible or parts replaced without decals, new decals must be applied. New decals are available from your authorized dealer.

2.2 GENERAL SAFETY

1. Read and understand the Operator's Manual and all safety signs before operating, maintaining, and adjusting.
2. Provide a first-aid kit for use in case of an accident. Store in a highly visible place.
3. Provide a fire extinguisher for use in case of an accident. Store in a highly visible place.
4. Wear appropriate protective gear. This list includes but is not limited to:
 - A hard hat
 - Protective shoes with slip resistant soles
 - Protective glasses or goggles
 - Heavy gloves
 - Wet weather gear
 - Hearing protection
5. Do not operate without guards or shields properly installed.
6. Do not allow riders.
7. **Wear appropriate ear protection for prolonged exposure to excessive noise.**
8. **(All Models) Set Blower on the ground, stop engine, set park brake, remove ignition key and wait for all moving parts to stop before dismounting to service or adjust.**
9. Clear the area of people, especially small children, before starting the unit.
10. Review all safety related items annually with all personnel who will be operating or maintaining the Blower.
11. Keep hands, feet, hair and clothing away from moving parts. Operate equipment only while seated in the operator's seat.

2.3 OPERATING SAFETY

1. Read and understand the Operator's Manual and all safety signs before operating, servicing or adjusting.
2. Before servicing or repairing, **Set blower on the ground, disengage PTO, stop engine, set park brake, Turn Off Tractor Engine, remove key, and wait for all moving parts to stop.**

Buffalo Turbine Warranty Policy

3.0 MACHINE WARRANTY INFORMATION

Buffalo Turbine warrants the DEBRIS BLOWER, to the original owner, to be free from defects in material and workmanship, under normal use and service. **All machines must have a completed registration form sent to Buffalo Turbine within 30 days of purchase for warranty to apply.** Obligation under this warranty shall extend for a period of 10 years from date of purchase and, at the option of Buffalo Turbine, replacement of any parts found, upon inspection by Buffalo Turbine, to be defective. Any parts replaced under warranty will have the remainder of the warranty from the original date of purchase.

Warranty parts during first 2 years will be shipped free of charge via standard ground shipping

If expedited shipping is required charges will be paid by the end user

Year 1: parts and labor

Year 2: parts only

Customer will be required to pay shipping charges for years 3-10

Year 3: Engine, per engine manufacturer's standard / Turbine Assembly / Frame (parts only)

Year 4-10: Turbine Assembly / Frame (parts will be prorated)

Buffalo Turbine reserves the right to incorporate improvements in material and design of its products without notice and is not obligated to make the same improvements to equipment previously manufactured.

ALL WARRANTY REPAIRS NEED PRE-APPROVAL BY A FACTORY PERSON (FROM BUFFALO TURBINE) PRIOR TO COMMENCING WITH A WARRANTY REPAIR TO INCLUDE SERIAL NUMBER AND HOURS FROM HOUR METER (IF EQUIPPED). PRE-APPROVAL WILL BE REQUIRED BY THE END USER AND DEALER/DISTRIBUTOR LEVEL.

Factory ordered Buffalo Turbine parts must be used when filing a warranty claim.

LIMITATIONS OF LIABILITY

This warranty is expressly in lieu of all other warranties expressed or implied and all other obligations or liabilities on our part of any kind or character, including liabilities for alleged representations or negligence. We neither assume nor authorize any other person to assume on our behalf, any liability in connection with the subsequent sale of the **DEBRIS BLOWER**. This warranty shall not apply to any DEBRIS BLOWER, which has been altered outside the factory in any way so as, in the judgment of Buffalo Turbine, to affect its operation or reliability, or which has been subject to misuse, neglect, or accident. This warranty does not cover parts and accessories, which are under separate guarantee from the manufacturers and service can be, obtained from their service facilities. No warranty is extended to regular service items such as lubricants, belts, paint and the like.

Original Instruction Manual

The Purchaser acknowledges having receiving training in the safe operation of the DEBRIS BLOWER and further acknowledges that Buffalo Turbine does not assume any liability resulting from the operation of the DEBRIS BLOWER in any manner other than described in the Operator's Manual supplied at the time of purchase.

WARRANTY VOID IF NOT REGISTERED (see Page 2 for warranty registration form)

DO NOT SPLIT THE TURBINE HOUSING FOR ANY REASON.

DO NOT ATTEMPT TO SERVICE OR DISASSEMBLE THE TURBINE BLOWER.

DO NOT USE THE TOP OF THE TURBINE HOUSING TO STRAP OR TIE DOWN BLOWER UNITS.

Unauthorized service work on the Turbine Blower will null and void all warranties.

If there are any questions regarding any of our products call Buffalo Turbine at 716 592 2700.

3.1 Warranty Registration Form

BUFFALO TURBINE

WARRANTY REGISTRATION FORM & INSPECTION REPORT

Any units not registered with Buffalo Turbine are not eligible for warranty claims
This form must be filled out by the dealer and signed by both the dealer and the customer at the time of delivery

Customer's Name _____ Dealer's Name _____

Address _____ Address _____

City, State, Zip, Country _____ City, State, Zip, Country _____

Email Address (important) _____ Email Address _____

Telephone Number _____

Blower Model _____

Circle one:

Serial Number _____

Commercial Use

Delivery Date _____

Private Use

DEALER INSPECTION REPORT

SAFETY CHECKS

_____ Tire Pressure Check -- Model KB

_____ All Decals Installed

_____ Wheel Bolts

_____ Review Operating and Safety Instructions

_____ Belt Tension

_____ Lubricate Machine

_____ Guards in Place

_____ Fasteners Tight

_____ Trailer assembly bolts properly installed and tightened

ALL 3 POINT HITCH MODELS: PTO SHAFTS MUST TELESCOPE IN EVERY POSITION

I have thoroughly instructed the buyer on the above described equipment which reviews the included Operator's Manual content, equipment care, adjustments, safe operation and applicable warranty policy.

Date _____

Dealer's Rep. Signature _____

The above equipment and Operator's Manual has been received by me and I have been thoroughly instructed as to the care, adjustments, safe operation and applicable warranty policy.

Date _____

Owner's Signature _____

PLEASE EMAIL TO BUFFALO TURBINE AT - service@buffaloturbine.com

Or fax to 716 592 2460

4.0 OPERATIONS

4.1 TO THE NEW OPERATOR OR OWNER

Buffalo Turbine Debris Blowers are designed to quickly and efficiently, blow away leaves, cuttings and other debris. The material is conveyed on a stream of high volume and velocity of air to remove it from the area of concern. When the material is removed, it gives a neat, professional look to the working area.

Many of the features incorporated into the machine are the result of suggestions made by customers like you. Read the manual carefully to learn to operate the machine safely and how to set it to provide maximum efficiency. The manual will take you step-by-step through your working day. By following the operating instructions in conjunction with a good maintenance program, your Blower will provide many years of trouble-free service.

Potential Mechanical Hazards while operating your machine:

Never operate the debris blower around others to prevent the possibility of being run over by equipment.

Never ride on your debris blower to prevent the possibility of being thrown off the machine or hurt severely.

Potential Crushing Hazards while operating your machine:

- Between tractor arms and blower frame arms
- Between tractor deck and blower guard shroud
- Between tractor deck and tractor arms
- Between Pin at the end of the mounting arms
- Between caster wheels and the ground



WARNING:

This Product can expose you to chemicals which are known to the State of California to cause cancer and birth defects or other reproductive harm.
For more information go to www.P65Warnings.ca.gov.

4.2 BREAK-IN

Although there are no operational restrictions on the Blower when it is used for the first time, it is recommended that the following mechanical items be checked:

A. Operating for first ½ hour

1. Re-torque all other fasteners and hardware.
2. Check that the driveline turns freely and that it can easily telescope without bottoming out.
3. Check set screw (nozzle pulley) to ensure it tightened.

B. Operating for first 5 hours

1. Re-torque all hardware and fasteners.
2. Check set screw (nozzle pulley) to ensure it tightened.
3. Go to the normal servicing and maintenance schedule as defined in the Maintenance Section of the manual.

C. Operating for first 50 hours

1. Change gearbox oil (SEE PG. 24)

4.3 PRE-OPERATION CHECKS

Efficient and safe operation of the Buffalo Turbine Blower requires that each operator reads and understands the operating procedures and all related safety precautions outlined in this section. A pre-operation checklist is provided for the operator. It is important for both personal safety and maintaining the good mechanical condition of the machine that this checklist is followed.

Before Operating the Blower and each time thereafter, the following areas should be checked off.

1. Make sure all guards and shields are in place, secured and functioning as designed.
2. Lubricate machine per maintenance schedule.
3. Ensure that the machine is properly attached to the (appropriate) power unit attaching arms and that the mounting pins are secured in position.
4. Ensure the PTO driveline is securely attached and can telescope easily.
5. Check that all clamp bands are secure.
6. Check the belts and pulleys for proper tension and alignment.

4.4 Attaching Blower to Tractor

1. Make sure the tractor has proper HP and is in good working order, including mounting brackets, PTO output shaft, and safety equipment.
2. Make sure there is enough room to safely drive up to the blower. Align mounting pins of the blower unit to match the tractor mounting brackets of the tractor. Engage into the mounting brackets and secure pins. (See Tractor attachment installation instructions)
3. Connect PTO shaft. **NEVER attempt to maintain or attach PTO shaft while tractor is running!**
4. Check Upper and lower limits.
5. Connect the remote nozzle control to a 12 volt system only. Red wire needs to be connected to positive terminal of battery. White wire needs to be connected to negative terminal of battery. (wiring schematic on PG. 18)
6. To unhook the blower unit from the tractor, reverse the above procedures. Always park the Blower unit and tractor in a dry, level area.

4.5 FIELD OPERATION

1. Do not direct debris blower towards people, pets, autos, windows, etc.
2. **Starting blower unit:** Always engage the tractor PTO control at a lower engine speed with nozzle pointed down or away.
3. The air stream direction is changed (in either direction) by moving the rocker switch located on the hand control box. The nozzle will stop turning by releasing the rocker switch. **ALWAYS CHECK THE GROUND CLEARANCE WHEN OPERATING THE NOZZLE IN THE DOWN VERTICAL POSITION.**
4. **Stopping blower unit:** Gradually slow the tractor RPM down to a lower speed using the throttle.
5. Disengage PTO and allow the blower fan speed to come to a stop.

NOTE: Make sure the control box wire harness is clear of all moving parts including the PTO shaft.

4.6 Operating RPM (All Models)

The manufacturer's tractor section normally recommends the unit be run at a RPM that will insure efficient attachment operation and hydrostatic drive functioning. The Blower can operate at a slower RPM if it can effectively move the debris. Vary ground speed with the hydrostatic transmission. Increase engine RPM to improve tractor efficiency.

Moving light material, such as dry leaves, requires much less wind than wet or heavier material.

Always try to blow with the wind. The Blower can be used for a wide variety of applications to move leaves, grass clippings, aeration plugs and debris. Drying wet areas has been another use with these powerful Debris Blowers.

4.7 Storage

At the end of the working season or before storing the blower unit, prepare the machine by following this procedure:

1. Select a storage area that is dry, level and free of debris.
2. Thoroughly wash the machine with a water hose to remove all debris and residue.
3. Run the machine at low RPM to dry the Blower Components.
4. Touch up all paint chips and scratches to prevent rusting.
5. Inspect for worn or failed components. Order the replacement parts and repair the blower unit when time allows. This will eliminate unnecessary down time at the start of next season.
6. Store in an enclosed building. If space is not available, cover with a waterproof tarpaulin and tie it down securely.
7. Store the machine away from areas of human activity.
8. Do not allow children to play around the stored unit.

5.0 TROUBLE SHOOTING

The Buffalo Turbine Debris Blower uses a high volume and velocity of air to move material from one place to another. The system is simple and reliable requiring minimal maintenance.

If you encounter a problem that is difficult to solve, even after reading through this trouble shooting section, please call your local dealer or distributor. **Before calling, please have this Operator’s Manual and the serial number from your Blower ready.**

In the following section, we have listed causes and solutions to the problems that you may have encountered.

TURN OFF ENGINE, REMOVE KEY, AND DISCONNECT BATTERY BEFORE SERVICING BLOWER UNITS. INSTALL GUARDS BEFORE OPERATING.

PROBLEM	CAUSE	SOLUTION
No air flow	Buildup of debris inside turbine	Remove nozzle and clean debris from inside turbine
	Broken coupling	Replace coupling
No air flow	Blower fan not turning	See solutions above
Reduced or no air flow	Blower fan turns	Air intake or exhaust restricted Shut off engine Blower or tractor – remove restrictions Debris cannot be allowed to build up between the blower fan and stationary vanes
Machine vibrates or Unusual sounds	Bearing or coupling failure Out-of-balance	Replace bearings or coupling Have your dealer check blower for damaged blades. Wash and clean blower fan blades

6.0 Machine Specifications

Model CPTOCE Series

Length: 63” With nozzle
44” Without nozzle

Width: 22”
Height: 24”
Weight: 285 lbs

Electrical System: 12 Volt
Input Power: PTO
Input RPM: Up to 3780 RPM

Outlet Size: Approximately 12”
Gearbox: Use Oil that covers SAE 90 EP **ONLY.**

7.0

MAINTENANCE SECTION

7.1 Maintenance Safety

1. Set Blower on a level surface, stop engine, set park brake, remove ignition key and wait for all moving parts to stop before dismounting to service, adjust or repair.
2. Reinstall and secure all guards removed for servicing before starting to use machine again. *We recommend wearing gloves when removing or installing the guard to avoid getting cut*
3. Securely support machine with blocks or safety stands when changing tires or working beneath it.

7.2 Fluids

Gearbox requires Oil that covers SAE 90 with EP additive (SEE PG. 21)

A Teflon spray type lubricant on the nozzle base and slides provides for freer rotation.

7.3 SERVICE CHECKLIST

See Lubrication and Maintenance sections for details of service. Copy this page to continue record.

TURN OFF TRACTOR, REMOVE KEY & DISCONNECT WIRE HARNESS BEFORE SERVICING BLOWER UNIT

CODE: LUBRICATE-(L) / CHECK-(*) / CHANGE-(C) / REPLACE-(B) / CLEAN-(CL)

SCHEDULED MAINTENANCE HOURS _____

SERVICED BY _____

MAINTENANCE

8 hrs or daily

(*) Remove all debris that has settled between the blower wheel fan and the stationary vanes.

Helps maintain peak performance.

(L) PTO Driveline

(*) Check Clamp Band Bolt for tightness

40 hours or weekly

(*) Check condition of belts

(L) Nozzle base slides (Teflon spray)

(*) Check set screw (nozzle pulley) to ensure it is tightened

(*) Check set screw (nozzle pulley) to ensure it is tightened

(*) Wash and Clean any dirt or grime build up that has accumulated on blower wheel fan blades. Helps to minimize vibration balance and maintain peak performance.

(*) Check condition of coupling (center section # 1256) connecting bolts and nuts during each oil change or when experiencing vibration or unusual noises

200hrs or annually

(CL) Machine

(CL) & (L) Driveline shield

(*) PTO Shaft U-Joints

500hrs

(C) Change gearbox oil (See PG.20)

DO NOT OPERATE BLOWER UNIT WITHOUT GUARDS SECURELY ATTACHED

*Debris Blowers, Vector Sprayers, Dusters
and Dust Control Systems*

Declaration of Conformity

According to EC Machinery Directive 2006/42/EC, Annex II B

We, Buffalo Turbine of Springville, New York, USA herewith declare, that the following described machine/machinery part is to be incorporated into a(n) machine/assembly with other machinery to make one machine and that its setting into operation is prohibited unless the machine, which shall be incorporated into the lower mentioned, complies with the requirement of the EC Machinery Directive 2006/42/EC.

Product: Debris blower

Type: BT-CPTOCE

Applicable EC Directives: Machinery Directive 2006/42/EC

Applicable Harmonized Standards: BSENISO 12100:2010

INSTALLATION INSTRUCTIONS & PARTS FOR THE MOREFLEX COUPLING

ALIGNMENT OF TURBINE SHAFT WITH SHAFT OF ENGINE IS CRITICAL

1. Install keys in both shafts.
2. Slide coupling flanges on both shafts (engine and turbine shafts)
3. Place Moreflex coupling CENTER SECTION between coupling flanges and secure with 4 bolts and TOPLOC nuts. The bolt heads are positioned against the coupling in alternating directions. Tighten all 4 bolts. DO NOT TIGHTEN SET SCREWS AT THIS TIME.
4. Check key for proper position under the set screw hole on both shafts.
5. Place several drops of Loctite 271 into these two holes only. Set screws and tapped screw holes must be free of dirt and oil for Loctite to work properly.
6. Install the set screws over the keys and tighten firmly.
7. Using a drill point, dimple each shaft through the other 2 set screw holes. Clean drill chips, oil and dirt before applying Loctite.
8. Place several drops of Loctite 271 in these 2 holes.
9. Install and tighten set screws in these 2 holes.
10. Check and retighten the 4 bolts that hold the coupling center section in place.
11. Visually inspect the unit and replace the guard. DO NOT OPERATE WITHOUT THE GUARDS IN PLACE.

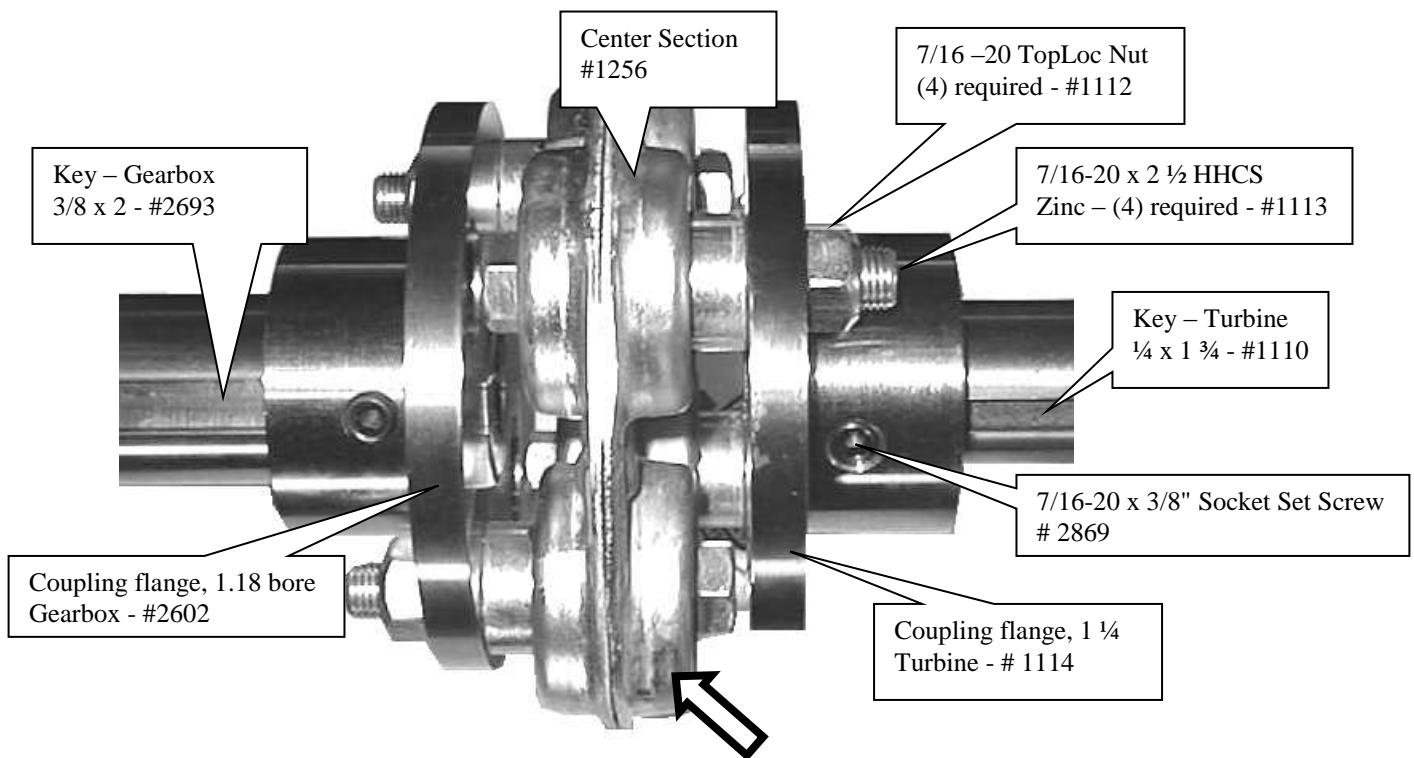

Part # 1256 (center section) is a "**WEAR**" item that should be visually checked each time the engine oil is changed. This coupling is equipped with special lock nuts. Occasionally check that all 4 nuts are securely fastened. LOOK FOR CRACKS IN THE RUBBER COMPOSITION THAT SURROUNDS THE 4 BUSHINGS. **Replace the center section when the rubber composition begins to show ANY signs of cracking OR an increase in vibration OR unusual sounds. When in doubt, call our Service Department.**

MOUNTING BLOWER ASSEMBLY ONTO FRAME **AND ALIGNMENT RECOMMENDATIONS**

1. Install blower assembly onto frame and tighten all of the bolts.
2. Remove all burrs and oil from the shafts and keyways (engine and blower shafts).
3. Using the supplied gauge, align the shafts parallel to each other (very important).
4. Check in four places around the shafts at 90° to each other.
5. When properly aligned, gauge should have little to no gap between itself and the shafts at any point along the gauge.
6. To adjust, move the engine. The 2 mounting brackets have tapped holes in each corner to help support and adjust the position of the engine. The 4 roll pins may need to be repositioned after alignment is completed and bolts are tightened.
7. Tighten all engine bolts and recheck alignment. Drill and install 4 roll pins in new position.

ACCEPTABLE

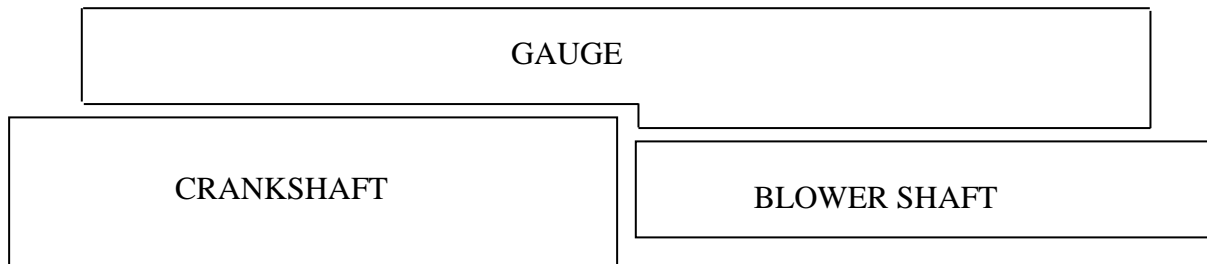

NOT ACCEPTABLE

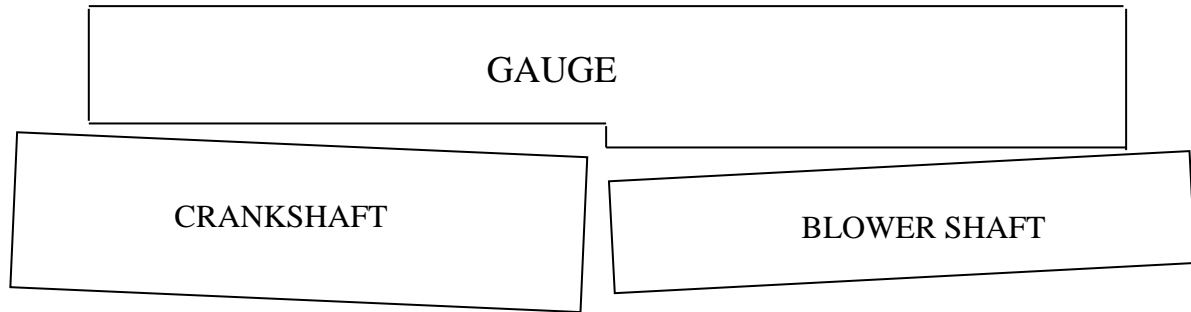

SECURELY ATTACH GUARDS BEFORE OPERATING BLOWER UNITS

BT-CPTOCE PARTS REFERENCE

(BEFORE SERIAL #29927)

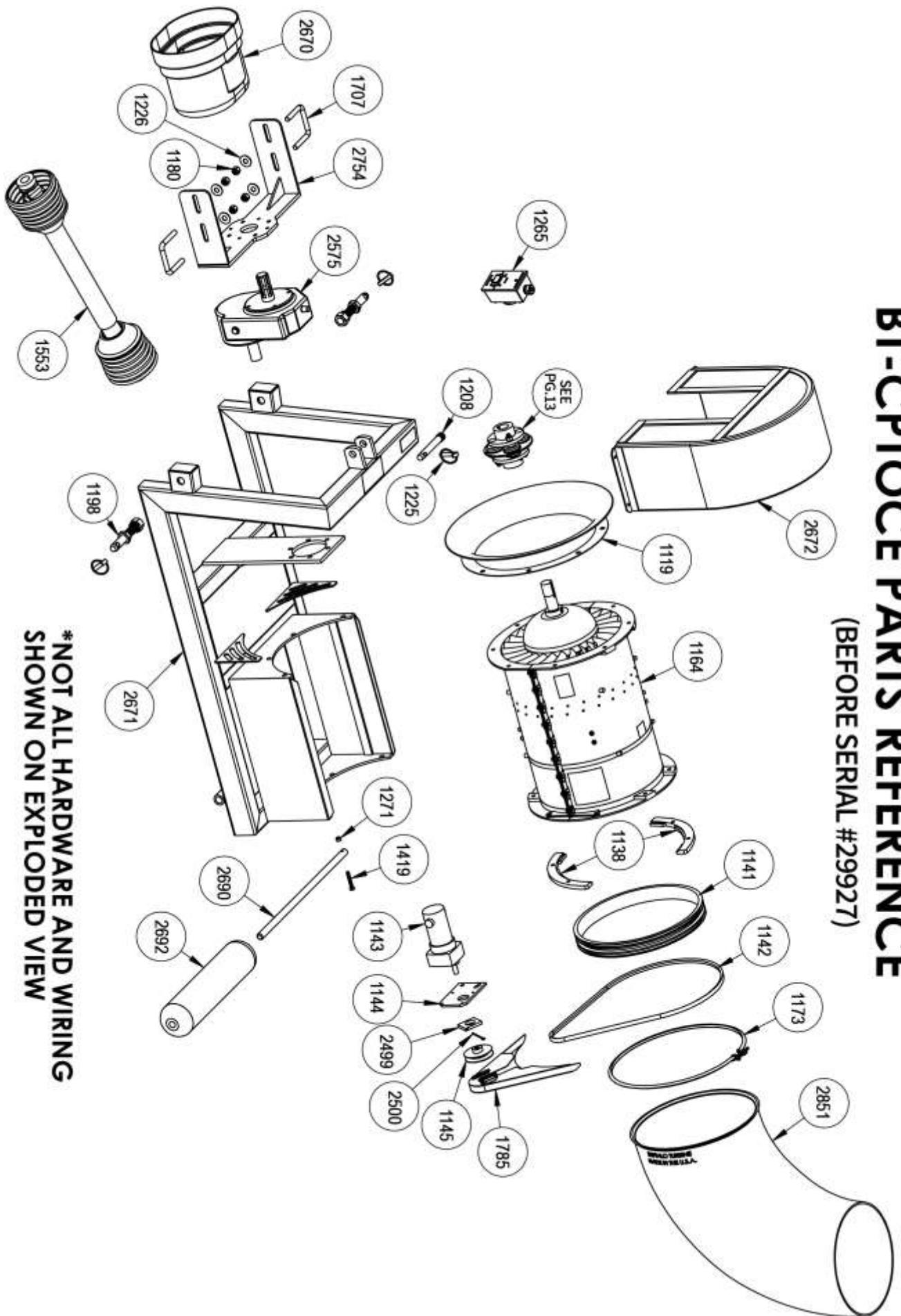

***NOT ALL HARDWARE AND WIRING SHOWN ON EXPLODED VIEW**

BT-CPTOCE PARTS REFERENCE

(BEGINNING WITH SERIAL #29927)

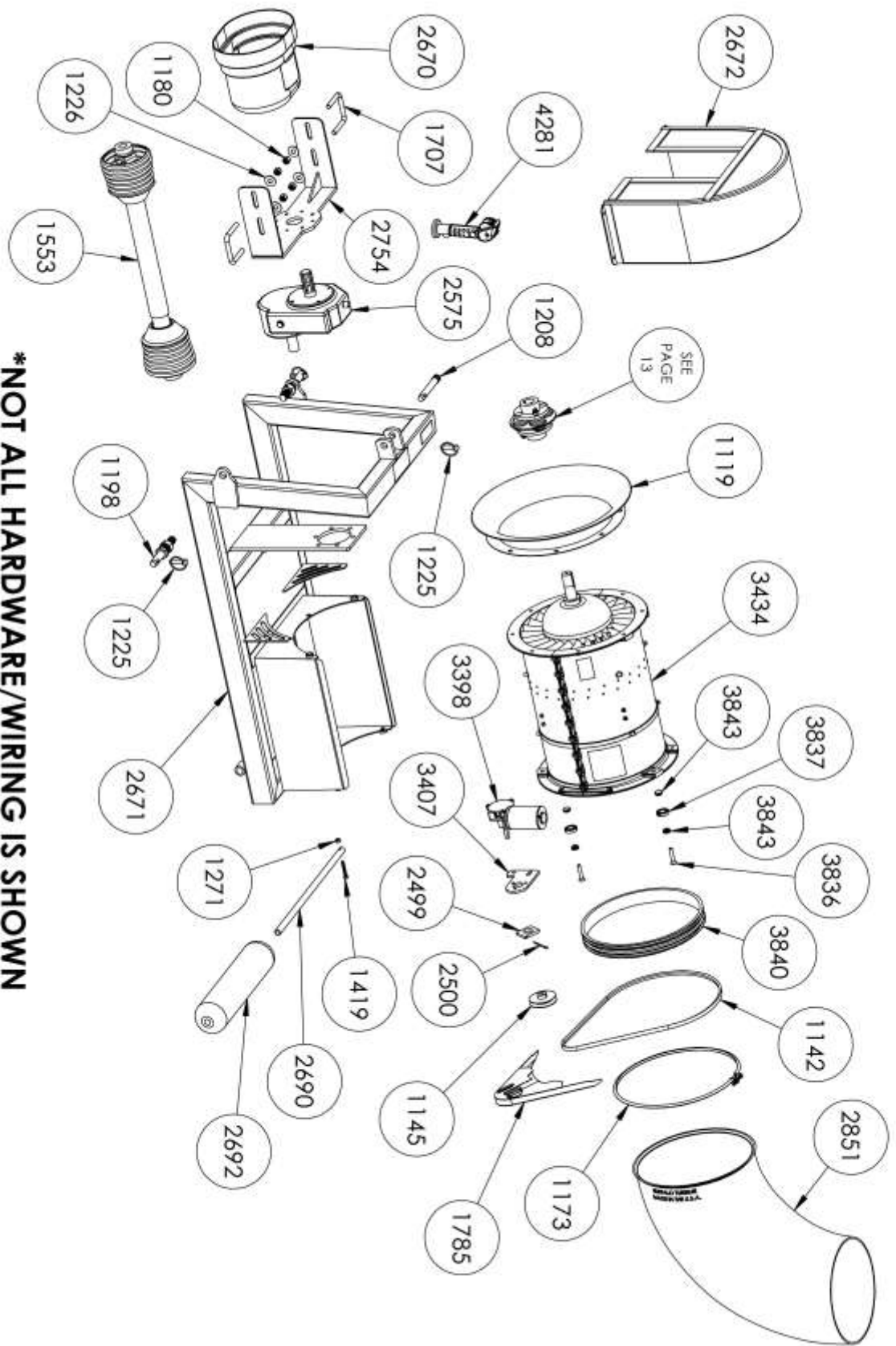

***NOT ALL HARDWARE/WIRING IS SHOWN**

BT-CPTOCE SUB ASSEMBLIES PARTS REFERENCE

PART # 1265 : WIRING HARNESS			
Ref #	Qty.	Description	Part #
1	2	6-32 PHILLIPS FLAT HEAD SCREW	1279
2	1	ROCKER SWITCH	1769
3	1	NOZZLE CONTROL BOX COVER	1304
4	1	1/4-20 NUT PLATE	1302
5	2	BOX FITTING	1295
6	2	2 WIRE BUSHING	1287
7	2	2 AND 4 WIRE NUT	1286
8	1	MAGNET	1300
9	1	1/4-20 X 3/4 HHCS	1258
10	1	CONTROL BOX HOUSING	1281

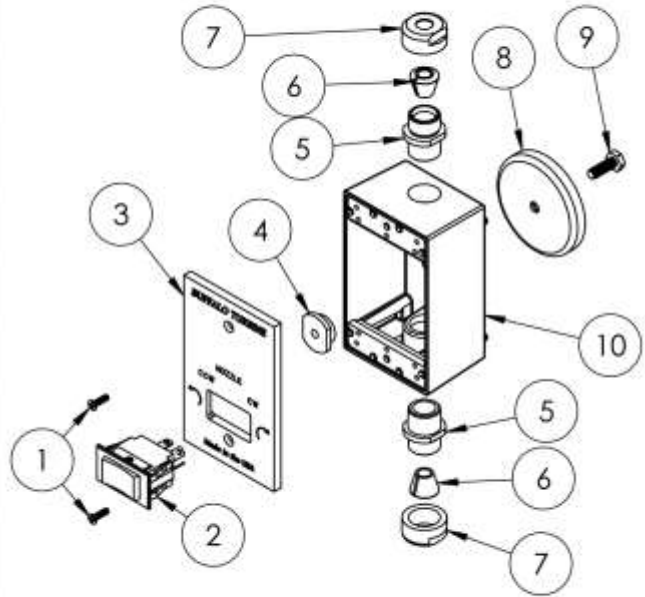

NOTE: NOT SHOWN BUT INCLUDED WITH PART #1265

Part #	Description	Qty.
1177	1/4 BLACK HEAT SHRINK	4
1178	3/8 BLACK HEAT SHRINK	8
1282	QUICK CONNECT FLAG TERMINAL	4
1283	BUTT CONNECTOR	3
1293	FUSE HOLDER	1
1294	20 AMP FUSE	1
1537	16-2 SJOOW CORD	156 in.
2023	16/14 FULLY INSULATED MALE QUICK DISCONNECT	2
2084	11172-03, CONNECTER PLUG, 2 POLE	1
2085	11172-02, CONNECTER PLUG, 2 POLE	1

WIRING SCHEMATIC CONTROL BOX

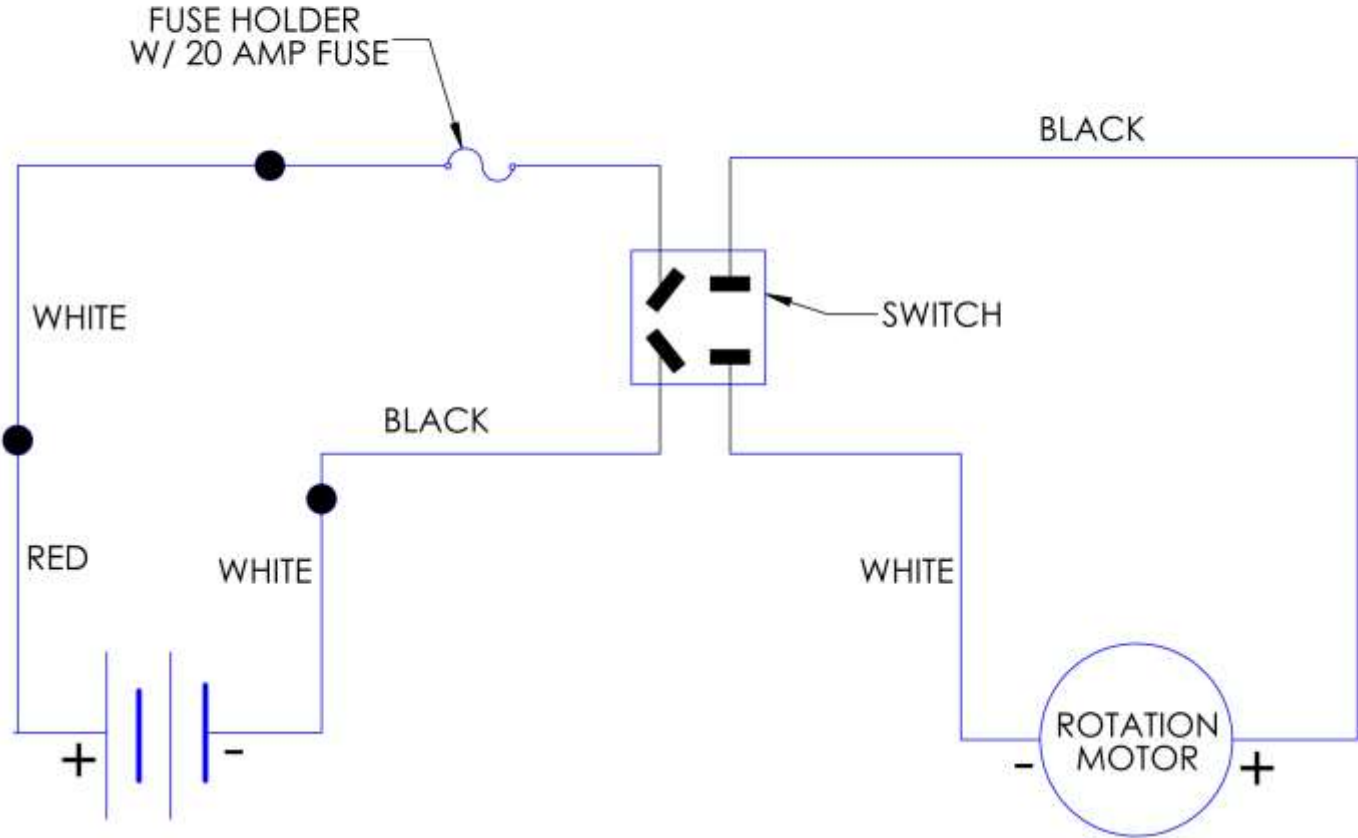

BILL OF MATERIALS FOR BT-CPTOCE			
REF PAGE #	PN	DESCRIPTION	QTY
	1100	3/8-24 X 1-1/4 HHCS ZINC GR 5	6
	1101	3/8-24 X 1-1/2 HHCS ZINC GRADE 5	3
	1102	3/8-24 X 1-3/4 HHCS ZINC	3
	1105	3/8-24 HEX NUT ZINC PLATED GRADE 5	14
	1106	SPACER-3/8 X 3/16 THICK WASHER	4
	1107	3/8 LOCK WASHER ZINC PLATED	16
	1108	3/8 FLAT WASHER ZINC PLATED	10
	1110	KEY, 1/4 X 1-1/2	1
	1112	7/16-20 TOPLOC NUT ZINC GRADE 5	4
	1113	7/16-20 X 2-1/2 HHCS ZINC GRADE 5	4
	1114	COUPLING FLANGE 1-1/4 BORE	1
16	1119	14-221-D1 BELLMOUTH	1
	1123	M8 X 1.25 X 3/4 HHCS PLATED	4
	1130	5/16-18 X 3/8 SET SCREW	1
16	1142	A-54 V-BELT	1
16	1145	SHEAVE AK32 X 1/2	1
	1156	SERIAL TAG	1
16	3434	KB BLOWER ASSEMBLY	1
	1169	3/4-20 X 1 HHCS ZINC	4
16	1173	CLAMP BAND W/ BOLT & NUT	1
16	1180	1/2-13 NYLOC NUT ZINC	4
16	1198	LIFT PINS WITH NUTS AND LOCKWASHERS	2
16	1208	TOP PIN, UPPER	1
16	1225	7/16" LYNCH PIN	3
16	1226	1/2 FLAT WASHER	4
	1228	ROTATING DRIVE HAZARD DECAL	1
	1256	MOREFLEX CENTER SECTION	1
	1259	1/4 LOCKWASHER	4
16	1271	5/16-18 HEX NYLOC NUT	1
16	1419	5/16-18 X 2 HHCS GR5 ZINC	1
	1540	5/16 LOCKWASHER ZINC	8
	1541	5/16 FLAT WASHER	4
16	1553	PTO SHAFT	1
	1669	3/4-20 X .055 HEAD INSERT	4
16	1707	U-BOLT	2
	1783	CE LABEL	1
16	1785	GUARD ROTATION MOTOR BELT	1
	1819	BLACK CABLE TIES	1
	1820	5/16-18 X 3/4" LONG HHCS ZINC	4
16	2499	PLASTIC BELT GUARD MOUNT	1
16	2500	1/8 X 2 1/2" COTTER PIN	1
16	2575	CPTO GEARBOX	1
	2602	COUPLING FLANGE 1.18 BORE (GEARBOX)	1
16	2670	PLASTIC END BELL, IIC SHIELD	1
16	2671	FRAME,BT-CPTO	1
16	2672	GUARD, BT-CPTO	1
	2680	10MM-1.5 X 25MM LONG HHCS ZINC GRADE 5	6
16	2690	MOUNTING SHAFT 21 3/8" FOR REAR ROLLER, CPTO	1
16	2692	REAR ROLLER ASSEMBLY	1
	2693	KEY, 5/16 X 1 1/2"	1
	2694	GEAR OIL	.171712
	2705	10MM SPLIT LOCKWASHER	6
16	2754	CPTO, RETRO-FIT SUPPORT BRACKET	1
16	2851	AEROSPACE POLYMER NOZZLE	1
	2869	7/16-20 x 3/8" SOCKET SET SCREW	4
	3177	CYCLONE PTO DECAL	2
	3221	CE PTO LABEL KIT	1
	3380	M10 SPLIT LOCKWASHER	6
	3384	NYLON SELF-RETAINING WASHER	1
16	3398	ROTATION MOTOR, RIGHT ANGLE, 12V, BI DIRECTIONAL	1
16	3407	ROTATION MOTOR BRACKET	1
16	3836	3/8"-24 X 2" LONG FHCS	4
16	3837	ELBOW BASE RING BEARING	4
16	3840	V-GROOVE BASE RING	1
16	3843	BEARING BUSHING	8
	4246	3/16" VINYL COATED LOOP CLAMP	2
16	4281	JOYSTICK CONTROLLER, 12' CORD	1

GEARBOX LUBRICATION INFORMATION

Type of Oil: A good quality SAE 90 EP gear oil is the basic requirement. A multi-grade gear oil may be used as long as the span includes the 90 weight (i.e. 75-90), and they have the EP (Extreme Pressure) additives.

Bima gearboxes are shipped to the manufacturer without oil. It is the responsibility of the manufacturer, dealer, or end user to properly fill the gearbox before initial use.

Filling: The gearbox should be filled while in a level position. Prior to filling the gearbox for the first time, the drain plug should be removed and coated with thread sealing compound (i.e. pipe dope) or Teflon tape, and then tightened firmly into the threads. Remove the level and fill plugs. Slowly pour the oil in the fill hole until it reaches the bottom of the level plug hole. Apply sealant to the level and fill plugs and replace in their respective holes. Oil required for Gearbox is approx. $\frac{3}{4}$ " quart (0.7 Liters).

Note that some gearboxes are equipped with sight plugs – these do not require removal, and oil should be added until it is just visible in the sight plug. Some gearboxes may be equipped with a dipstick on the fill plug – fill with oil until the level reaches the ring inscribed on the dipstick.

Changing: It is recommended that the oil be changed after the first 50 hours of use, and then after every 500 hours of use. The initial change is critical to remove fine metal particles produced as the gears polish their contact surfaces. Flushing the gearbox with a solvent is not required.

Checking: Remove the level plug and check if the oil is at the proper level (if equipped with a dipstick, check the level against the ring inscribed on the tube). Add oil as required.

If a gearbox loses oil during use, inspect oil seals for damage or leaking. If a gearbox repeatedly loses oil from its seals, it is an indication that the internal pressure is too high. Causes of high internal pressure may be:

- Overfilling with oil (especially when used at higher rpm's)
- Gearbox being used at too high a load or duty cycle
- Overheating
- Incorrectly installed oil seal
- Damage to sealing surface on shaft

A breather plug can sometimes help alleviate high internal pressures due to high loads and/or duty cycles, but is not a solution for an undersized gearbox.

If any covers are removed for inspection, scrape off any old sealant from all surfaces and re-seal with an oil resistant RTV sealant (Permatex Blue #80022 or equivalent).

OPTIONS PTO, HYDRAULIC, FRONT MOUNT, ELECTRIC

NOZZLES



Aerospace Polymer Nozzle - Part# 2851
Standard Clamp Band - Part# 1173



Flexible Nozzle Assembly - Part# 3345
Various lengths available.
Ideal for rough terrain.

Gyratory Atomizing Nozzle - Part# 2547
(Safety guard removed for clarity)



ALUMINUM NOZZLES

Optional aluminum nozzles **will not** connect to the standard Aerospace Polymer Nozzle (Part# 2851). Requires: **Two 45° elbow segments (Part# 1171)** and two additional clamp bands (Part# 1173).

- 12" Nozzle Extension - Part# 1468
- 15" Nozzle Extension - Part# 1842
- 20" Nozzle Extension - Part# 1845

10" Round Nozzle - Part# 1417
12" Round Nozzle - Part# 1172
Improves air velocity with lower horsepower and hydraulic blower units



12" Rectangular Nozzle - Part# 1469
19" Rectangular Nozzle - Part# 1425
5.5"x15" opening - extra length/more concentrated air flow. Uses - heavy wet debris, plugs, top dressing. No ground clearance in the vertical down position.



Fishtail Nozzle - Part# 1743
5"x30" (wide angle) opening. Distributes a large volume of air at a lower velocity over a wide area. Easily converts blower into a "Greens Fan". Adaptable to all models. Not as effective at moving debris.



1" HYDRAULIC HOSES

Part# 3922

For hydraulic machines with flow rates over 25gmp.
Quantity needed: 2



FORK POCKET

Part# 3894

Great for moving blowers around jobsites and bed mount / skid mount applications.



ROTATION BEARING KIT

Part# 3838

Increases rotation speed and reduces load on rotation motor.



BUFFALO TURBINE PRODUCTS

CYCLONE 8000

The Cyclone 8000 Debris Blower is strategically priced to fit most budgets. This little powerhouse is already proving its worthiness in saving Time and Labor.



MEGA

The word "MEGA" is defined as Impressive, Extreme and Mammoth. The NEW Buffalo Turbine MEGA lives up to its name!



CYCLONE PTO

The Cyclone PTO incorporates an "Advanced" direct drive gearbox which significantly reduces routine maintenance. At 238lbs, it's the lightest, meanest turbine style PTO blower available!



CYCLONE SQUARED

The Cyclone Squared with its "Twin Turbines", and wireless controlled dual independent nozzles, in most cases can handle twice the work in half the time. This versatile powerhouse is already a favorite on Golf courses, Racetracks, and the Paving Industry.



CYCLONE KB4

The Cyclone KB4 with its "More Powerful" CH740 Kohler Engine and a "State of the Art" Wireless Remote System is the most powerful KB unit to date.



HYDRAULIC

The Hydraulic debris blower features our built in "flow and pressure" control system and easily attaches to most skid steers. This handy attachment comes complete with mounting plate and hoses.

