

THE BEST HAS A NAME

ORSI

44° 41' 13" N
11° 20' 17" E



SIDE MULCHERS

WWW.ORSIGROUP.IT



HEADQUARTER

MASCARINO DI CASTELLO D'ARGILE (BO) ITALY



THE ORSI STORY

ORSI, THE BRAND THAT MANUFACTURES HIGH-TECH 100% MADE IN ITALY, GRASS CUTTING MACHINES. USING THE CONCEPT OF TRADITION OF THE HISTORY OF ITALIAN MANUFACTURING DESIGN ESPECIALLY IN THE BOLOGNA AREA.

ORSI factories smell of history and tradition, but always thinking about continuous innovation and preserving their identity over time.

From this union was born *in 1979* from the idea of a young Stefano Orsi, the manufacturing of agricultural machinery. A young entrepreneur who immediately focused on building innovative machines for those years whilst trying to understand what the farmers of his beloved " Emilia Romagna " region were asking for".

To realize his idea, Orsi started trying to satisfy the concept of Italianness making his machines with care and devotion. Listening to the advice that came from farmers in the area, who were looking for machines that did not exist at that time, hence the first side mulcher. A machine that owes its creation *in 1982* to ORSI!

In 1989 thanks to the continuous growth of the Brand in the Italian market, ORSI began to export to France first, and then quickly expanded to all other European markets.

Today the brand counts with distributors all over the world, always trying with its own philosophy to satisfy the different needs in each very different market.

The atmosphere inside the two production complexes, Grizzana Morandi and Castello d'Argile, both in the province of Bologna, exude enthusiasm in trying to improve continuously the product, trying to innovate its machines with technological and avant-garde solutions.

Many of the mechanical processes are carried out in the first factory, whilst the headquarters with administration and further manufacturing/assembling are located at the second.

Just think of the new "Frontal" side mulcher machine that was launched on the market *in 2020* to meet the needs of many end-users who today can work in perfect comfort and safety having the machine fitted to the front Linkage / PTO of the tractor, an absolute novelty in the market of mulchers.

A total of around 110 people work between the two production complexes.

The sense of Italianness in ORSI is always found in hearing Stefano Orsi say "for us, made in Italy means that Italians should like machines first".

ORSI company is a 'family' that loves their country and never gives up working with dreams and ambition as in 1979.



CONSTANT EVOLUTION

1982



Mediante un sistema autoelevante, ogni necessità di un continuo adattamento al terreno e raggiungono un'inclinazione di oltre 70° per un'accurata pulizia di fossi e canalette.

Le nostre trinciatrici si possono usare sia all'interno che all'esterno della carreggiata del trattore, per la pulizia di frutteti, vigneti e cigli di strade.

ORSI
Temporanea al vostro servizio

CARATTERISTICHE GENERALI

Modello	Lunghezza di taglio cm	Potenza min richiesta kW	Potenza max richiesta kW	Numero coltelli	Vel. max di marcia km/h	Velocità normale km/h	Profondità di taglio cm	Peso kg
T 32 S	105	25	40	32	5,40	2,430	150-180	300
T 36 S	120	30	45	36	5,40	2,430	180-170	320
T 42 S	150	30	45	42	5,40	2,100	120-180	320
T 48 S	180	35	50	48	5,40	3,430	150-190	370
T 52 S	195	30	40	32	5,40	3,430	240-260	320

ORSI ANDREA
40050 MASCARINO DI CASTELLO D'AROLE
(Bologna) ITALY
Via Borloghio, 18 - Tel. 051/974767 - 975431
Telex 5108180 OSV I

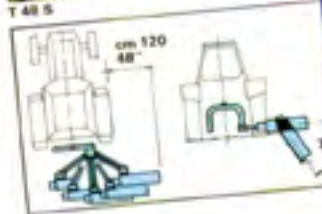

**BASTA CON LA FATICA!
RIVOLGITI A ORSI
E RISOLVI MILLE PROBLEMI**



**ORSI HA CREATO PER TE
UNA VASTA GAMMA DI TRINCIATRICI
PER UNO SVARIATO UTILIZZO**

TODAY



CERTIFICATIONS



CERTIFICATO



ISO 9001:2015

ORSI GROUP S.p.A.

Il presente certificato è valido
sotto le condizioni di
validità e di rinnovo
della norma ISO 9001:2015
Prestazioni di servizio

ORSI GROUP S.p.A.
Sede Legale
Sede Operativa: Cortina (Trento)



000 00 000



ANTICORROSIVE TREATMENT

ANTICORROSIVE POWDER TREATMENT

- Shot Blasting SA Ø 2,5
- Primer application in zinc phosphate epoxy powder thickness 60-80 µm
- EXTRA polyurethane finishing powder (UV-resistant) thickness 60-80 µm polymerization at 180° for 20'
- Final dry thickness 120-160
- Orange colour RAL 2011
- Corrosivity class c5-i following DIN55633 and DIN EN ISO 12944-6 norms
- Salt spry resistance 2000h

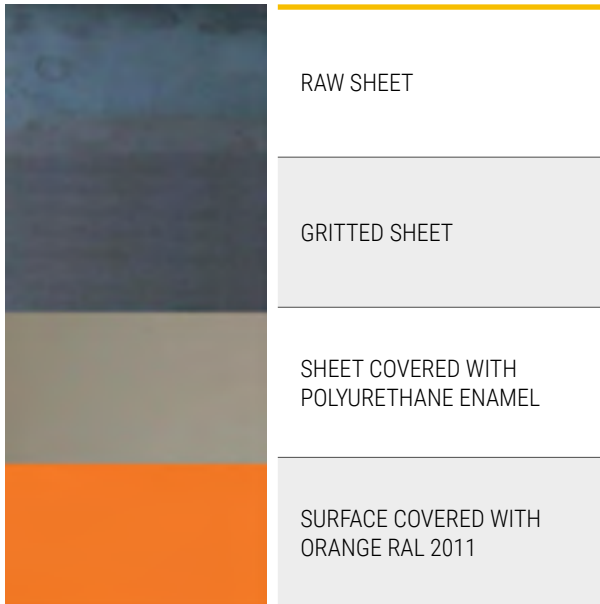

N.B. These cycles are applied on all our equipment.

ANTICORROSIVE LIQUID TREATMENT FOR MECHANICAL AND HYDRAULIC COMPONENTS

HIGH STRENGHT CYCLE

- Shot Blasting sa Ø 2,5
- Epoxy bi-component primer application in zinc CT90
- Expoprimer application CT113 grey 7035
- EXTRA bi-component polyurethane enamel application (UV-resistant)
- Final dry thickness 350-400 µm

STANDARD CYCLE

- Shot Blasting sa Ø 2,5
- Expoprimer application CT113 grey 7035
- EXTRA bi-component polyurethane enamel application (UV-resistant)
- Final dry thickness 180-200 µm

“WHY AN EXCELLENT PAINTING IS IMPORTANT”

BECAUSE IT KEEPS THE PRICE OF THE MACHINE ON THE SECOND-HAND MARKET.



USE OF THE FLAIL MULCHER

GRASS MAINTENANCE AND VINE SHOOTS

MODEL	Grass, small bushes, leaves	Grass, prunings, small wood, brambles, fibrous plants, brushwood	Grass, meadows, parks, gardens, sports fields	Prunings, wood	Road edges, ditches, embankments, river edges, irrigation channels	Big size of vine shoots and big size of wood
ENERGY	✓	✓	✓	-	✓	-
VULCANIC PLUS V24 VULCANIC PLUS V24 OFFSET	✓	✓	✓	✓	✓	-
COMPETITION GS PRIMATIST GS	✓	✓	✓	✓	✓	-
PRIMATIST PLUS GS MAGNUM PLUS GS	✓	✓	✓	✓	✓	✓

SIDE MULCHERS



WHY WE USE STRENX?

Superior properties

Strenx® steel has extremely consistent properties, ensuring precision and efficiency in the workshop.

If you think all steel is basically the same, Strenx® performance steel will change your thinking. Strong and reliable from surface to core, Strenx® steel features exceptional surface quality as well as impressive thickness and flatness tolerances verified by the Strenx® guarantees. The steel's properties - yield and tensile strength, bending performance, impact toughness - are carefully tested to ensure reliability and consistency in every delivery.



WHY WE USE HARDOX?

Hardox® 450

The most popular abrasion-resistant steel with excellent structural properties.

Hardox® 450 is an abrasion-resistant steel with a nominal hardness of 450 HBW. Hardox® 450 combines good bendability and weldability with an option for guaranteed impact toughness (Hardox® 450 Tuf).

The products can be used in many different components and structures that are subject to wear. Hardox® 450, with an extra 50 Brinell hardness over our 400 grade, provides better dent and abrasion resistance as well as longer wear life, so you can achieve even greater savings.

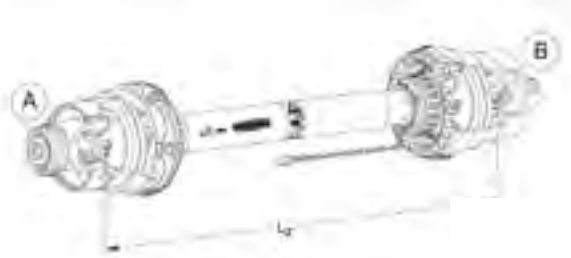

CONSTANT VELOCITY DRIVE DOUBLE CARDAN

for greater regularity and safety when moving even with particularly high working angles

CUTTING HEAD SELF-LEVELING system
 by means of hydraulic floating

HYDRAULIC SIDE MOVEMENT

with adjustable ram and double acting anti-creep valve

ROBUST AND ERGONOMIC FRAME

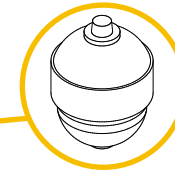

“SMART SAFETY” HYDRO-PNEUMATIC “NON STOP” SHOCK ABSORBER SAFETY SYSTEM

in the event of meeting an obstruction, it protects the structural parts from potential breakages and accidental damage. As the head is forced back by the obstruction, some of the oil contained in the hydraulic cylinder of the machine transfers into the nitrogen pressurized accumulator which brings the machine back to working position once the obstacle has been passed

SUPPORT FOOT IN REST POSITION

ADJUSTABLE SIDE SKIDS TO CONTROL THE WORKING HEIGHT

ELECTRONICALLY BALANCED ROTOR

with boron steel forest-type tool holders in professional models

COUNTER KNIFE

Increased rows of counter knives hold the material in for more complete shredding

CUTTING CHAMBER

made up of a double frame in some models that increases resistance and protects the integrity of the machine, avoiding damage to the hood

REAR ROLLER WITH ANTI-FLOODING PROFILE

for uniform and rapid discharge of the chopped product, in the professional ranges as standard with 4 tapered roller bearings, mud scraper and interchangeable central body with two positions 1 self-cleaning, it is characterized by an automatic cleaning system of the roller thanks to the very close position to the rotor, 2 rear support

ROAD EDGES, DITCHES,
GARDENS AND GREEN AREAS

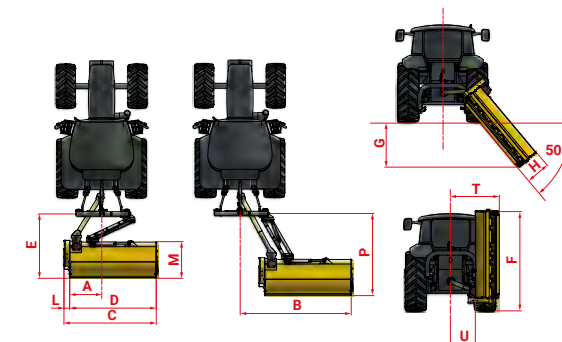
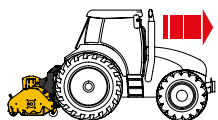

	A	B	C	D	E	F	G	H	L	M	P	S	T	U
	cm/in	cm/in	cm/in	cm/in	cm/in	cm/in	cm/in	cm/in	cm/in	cm/in	cm/in	cm/in	cm/in	cm/in
105	72/28	161/63	113/44	105/41	104/41	113/44	80/31	32/13	8/3	52/20	130/51	47/19	123/48	73/29
130	72/28	186/73	140/55	132/52	104/41	140/55	105/41	30/12	8/3	52/20	130/51	47/19	123/48	73/29
155	72/28	209/82	163/64	155/61	104/41	163/64	128/50	30/12	8/3	52/20	130/51	47/19	123/48	73/29



DIRECTION OF ROTATION OF P.T.O.

ENERGY

AGRICULTURAL SERIES



STRENGTH POINTS



SELF-CLEANING ROLLER



SAFETY AND SELF LEVELLING BREAKAWAY COUPLING





COUNTER KNIFE
Increased rows of counter knives hold the material in for more complete shredding



FREE-WHEEL IN GEARBOX

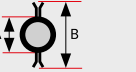

SWING BEARINGS DOUBLE BALL SLEWING BEARING

ENERGY				
TECHNICAL SPECIFICATIONS				
Working width		105 cm / 41 in	132 cm / 52 in	155 cm / 61 in
Machine weight		215 - 250 kg / 474 - 571 lb	232 - 265 kg / 511 - 584 lb	255 - 290 kg / 562 - 639 lb
tools	 knives standard max Ø 1,5 cm	48	64	80
	 hammers optional max Ø 2,5 cm - kg 0,2	24	32	40
rotor Ø		A mm / in	90 x 8 mm / 4 x 0,3 in	95 x 8 mm / 3,7 x 0,3 in
		B mm / in	265 mm / 10 in	271 mm / 11 in
N° belts		3	3	3
CAT.		0	I	I
540 RPM PTO	Rotor revolutions / peripheral tool speed	3078 rpm - 42,68 m/sec	3078 rpm - 42,68 m/sec	3078 rpm - 43,65 m/sec
HP max transmission		30 hp	30 hp	30 hp
Utilization		rear mounted		

TRACTOR REQUIREMENTS				
Minimum weight		650 kg / 1433 lb	700 kg / 1543 lb	800 kg / 1764 lb
Minimum wheels setting		100 cm / 39 in	110 cm / 43 in	130 cm / 51 in

ENERGY	105	130	155	
MACHINE				
Gear box position	internal gearbox on top of hood	internal gearbox on top of hood	internal gearbox on top of hood	
Monocoque skin th. 3 mm	✓	✓	✓	
Counter knife	✓	✓	✓	
Front protections	✓	✓	✓	
Self-cleaning rear roller Ø 102 mm	✓	✓	✓	
Reflectors	✓	✓	✓	
Side Skids	✓	✓	✓	
TRANSMISSION				
Cardan shaft 4 X 1200 1"3/8 Z6+1"3/8 Z6	✓	✓	✓	
Free-wheel in gearbox	✓	✓	✓	
Swing bearings double column of balls	✓	✓	✓	
Wide angle cardan shaft 4 X 1400	•	•	•	
Hammer set supplied separately	•	•	•	
SAFETY				
Mechanical safety and self-leveling system with double extra linkage	✓	✓	✓	
HYDRAULIC SYSTEM				
Hydraulic swing out	✓	✓	✓	
Hydraulic angleing	✓	✓	✓	

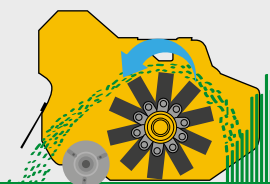

Position of the self-cleaning rear roller for discharging the mulched product behind the roller for higher output





**ROAD EDGES, DITCHES,
GARDENS AND GREEN AREAS**

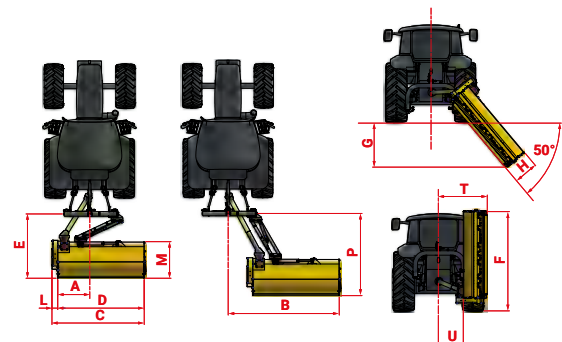

	A	B	C	D	E	F	G	H	L	M	P	S	T	U
	cm/in	cm/in	cm/in	cm/in	cm/in	cm/in	cm/in	cm/in	cm/in	cm/in	cm/in	cm/in	cm/in	cm/in
135	85/33	180/71	151/59	135/53	161/63	220/87	95/37	44/17	16/6	71/28	193/76	47/19	150/59	90/35
165	85/33	210/83	178/70	162/64	161/63	247/97	122/48	44/17	16/6	71/28	193/76	47/19	150/59	90/35
200	85/33	237/93	208/82	192/76	161/63	277/109	152/60	44/17	16/6	71/28	193/76	47/19	150/59	90/35



VULCANIC V24 PLUS

AGRICULTURAL SERIES

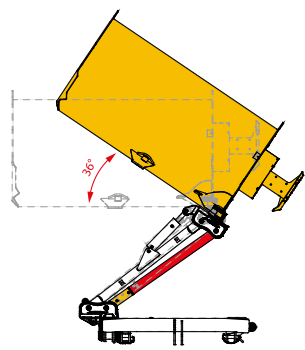

OLEOPNEUMATIC ANTI-SHOCK DEVICE (optional) in the event of meeting an obstruction, it protects the structural parts from potential breakages and accidental damage. As the head is forced back by the obstruction, some of the oil contained in the hydraulic cylinder of the machine transfers into the nitrogen pressurized accumulator which brings the machine back to working position once the obstacle has been passed.



WIDE ANGLE CARDAN SHAFT (optional)

STRENGTH POINTS



SELF-CLEANING ROLLER



DOUBLE COUNTER KNIFE
Increased rows of counter knives hold the material in for more complete shredding.



FREE-WHEEL IN GEARBOX

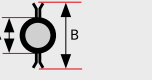

SWING BEARINGS DOUBLE BALL SLEWING BEARING

VULCANIC V24 PLUS		135	165	200
TECHNICAL SPECIFICATIONS				
Working width		135 cm / 53 in	162 cm / 64 in	192 cm / 76 in
Machine weight		490 - 533 kg / 1080 - 1175 lb	510 - 553 kg / 1124 - 1219 lb	525 - 570 kg / 1157 - 1257 lb
tools	 knives max Ø 3 cm	24	32	40
	 hammers max Ø 4 cm - Kg 1	12	16	20
rotor Ø		A	140 x 8 mm / 6 x 0,3 in	140 x 8 mm / 6 x 0,3 in
		B	376 mm / 15 in	376 mm / 15 in
N° Belts		4	4	4
CAT.		I - II	I - II	I - II
540 RPM PTO	Rotor revolutions / peripheral tool speed	2300 rpm - 45,25 m/sec	2300 rpm - 45,25 m/sec	2300 rpm - 45,25 m/sec
HP max transmission		60 hp	60 hp	60 hp
Utilization		rear mounted		
TRACTOR REQUIREMENTS				
Minimum weight		1500 kg / 3307 lb	1600 kg / 3527 lb	1700 kg / 3748 lb
Minimum wheels setting		160 cm / 63 in	170 cm / 67 in	180 cm / 71 in

VULCANIC PLUS		135	165	200
MACHINE				
Gear box position		internal gearbox on top of hood	internal gearbox on top of hood	internal gearbox on top of hood
Monocoque skin th. 4 mm		✓	✓	✓
Double counter knife		✓	✓	✓
Front protections		✓	✓	✓
Steel pivot points		✓	✓	✓
Steel main pivot point		✓	✓	✓
Self-cleaning rear roller Ø 140 mm		✓	✓	✓
Reflectors		✓	✓	✓
Side skids		✓	✓	•
Chains set supplied separately		•	•	•
TRANSMISSION				
Cardan shaft 5 X 2000 1"3/8 Z6+1"3/8 Z6		✓	✓	✓
Tool screw in steel 12.9		✓	✓	✓
Free-wheel in gearbox		✓	✓	✓
Swing bearings double column of balls		✓	✓	✓
Wide angle cardan shaft 6 X 2000 1"3/8 Z6+1"3/8 Z6		•	•	•
Knives set supplied separately		•	•	•
SAFETY				
Oleopneumatic anti-shock device		•	•	•
HYDRAULIC SYSTEM				
Hydraulic swing out		✓	✓	✓
Hydraulic angleing		✓	✓	✓

VULCANIC PLUS

AGRICULTURAL SERIES

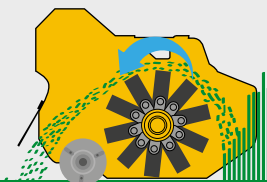

Position of the self-cleaning rear roller for discharging the mulched product behind the roller for higher output





**ROAD EDGES, DITCHES,
GARDENS AND GREEN AREAS**

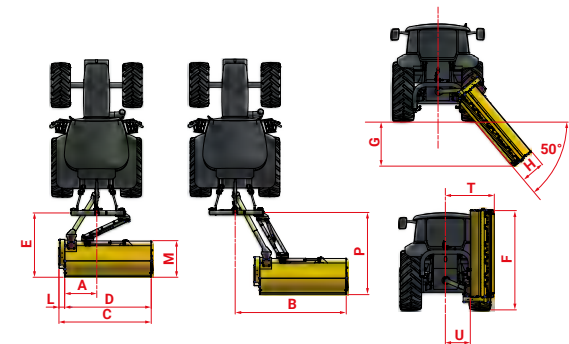

	A	B	C	D	E	F	G	H	L	M	P	S	T	U
	cm/in	cm/in	cm/in	cm/in	cm/in	cm/in	cm/in	cm/in	cm/in	cm/in	cm/in	cm/in	cm/in	cm/in
135	27/11	238/94	183/72	135/53	161/63	253/100	120/47	44/17	42/17	81/32	193/76	48/19	150/59	90/35
165	27/11	265/104	210/83	162/64	161/63	280/110	147/58	44/17	42/17	81/32	193/76	48/19	150/59	90/35
200	27/11	295/116	240/94	192/76	161/63	310/122	177/70	44/17	42/17	81/32	193/76	48/19	150/59	90/35

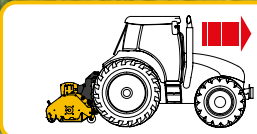

DIRECTION OF ROTATION OF P.T.O.

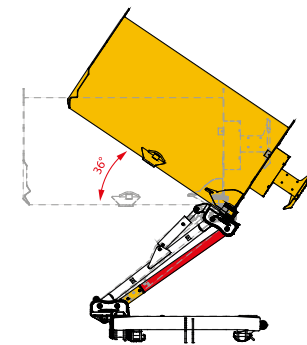

OLEOPNEUMATIC ANTI-SHOCK DEVICE (optional) in the event of meeting an obstruction, it protects the structural parts from potential breakages and accidental damage. As the head is forced back by the obstruction, some of the oil contained in the hydraulic cylinder of the machine transfers into the nitrogen pressurized accumulator which brings the machine back to working position once the obstacle has been passed.



WIDE ANGLE CARDAN SHAFT (optional)

VULCANIC V24 OFF SET

AGRICULTURAL SERIES



40 - 70 HP



STRENGTH POINTS



SELF-CLEANING ROLLER



AUTOMATIC BELTS TENSIONER
The automatic tensioning system as well as allowing constant power transmission reduces belts wear



DOUBLE COUNTER KNIFE
Increased rows of counter knives hold the material in for more complete shredding



FREE-WHEEL IN GEARBOX



SWING BEARINGS DOUBLE BALL SLEWING BEARING

VULCANIC V24 OFF SET		135	165	200
TECHNICAL SPECIFICATIONS				
Working width		135 cm / 53 in	162 cm / 64 in	192 cm / 76 in
Machine weight		500 - 545 kg / 1102 - 1202 lb	530 - 570 kg / 1168 - 1257 lb	550 - 600 kg / 1213 - 1323 lb
tools	knives max Ø 3 cm	24	32	40
	hammers max Ø 4 cm - Kg 1	12	16	20
rotor Ø	A	140 x 8 mm / 6 x 0,3 in	140 x 8 mm / 6 x 0,3 in	140 x 8 mm / 6 x 0,3 in
	B	376 mm / 15 in	376 mm / 15 in	376 mm / 15 in
N° belts		4	4	4
CAT.		I - II	I - II	I - II
540 RPM PTO	Rotor revolutions / peripheral tool speed	2300 rpm - 45,25 m/sec	2300 rpm - 45,25 m/sec	2300 rpm - 45,25 m/sec
HP max transmission		60 hp	60 hp	60 hp
Utilization		rear mounted		
TRACTOR REQUIREMENTS				
Minimum weight		1500 kg / 3307 lb	1600 kg / 3527 lb	1700 kg / 3748 lb
Minimum wheels setting		160 cm / 63 in	170 cm / 67 in	180 cm / 71 in

VULCANIC V24 OFF SET		135	165	200
MACHINE				
Gear box position		external gearbox on end of hood	external gearbox on end of hood	external gearbox on end of hood
Monocoque skin th. 4 mm		✓	✓	✓
Double counter knife		✓	✓	✓
Front protections		✓	✓	✓
Steel pivot points		✓	✓	✓
Steel main pivot point		✓	✓	✓
Self-cleaning rear roller Ø 140 mm		✓	✓	✓
Reflectors		✓	✓	✓
Side skids		•	•	•
Knives set supplied separately		•	•	•
TRANSMISSION				
Cardan shaft 5 X 2000 1"3/8 Z6+1"3/8 Z6		✓	✓	✓
Tool screw in steel 12.9		✓	✓	✓
Free-wheel in gearbox		✓	✓	✓
Swing bearings double column of balls		✓	✓	✓
Automatic belt tensioner		✓	✓	✓
Wide angle cardan shaft 6 X 2000 1"3/8 Z6+1"3/8 Z6		•	•	•
Knives set supplied separately		•	•	•
SAFETY				
Oleopneumatic anti-shock device		•	•	•
HYDRAULIC SYSTEM				
Hydraulic swing out		✓	✓	✓
Hydraulic angling		✓	✓	✓

✓ STANDARD EQUIPMENT | • OPTIONAL EQUIPMENT | - NOT AVAILABLE

VULCANIC OFF SET

AGRICULTURAL SERIES

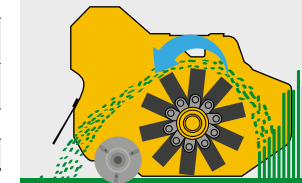

Position of the self-cleaning rear roller for discharging the mulched product behind the roller for higher output





**ROAD EDGES, DITCHES,
RIVER EDGES, PRUNINGS**

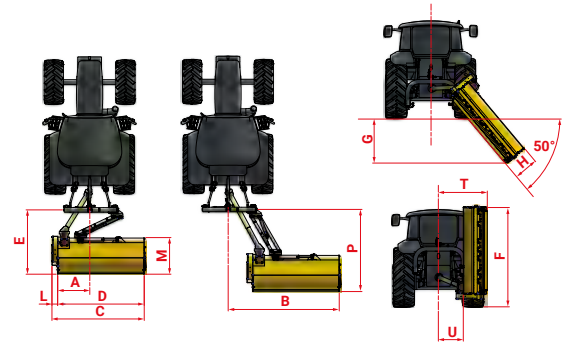

	A	B	C	D	E	F	G	H	L	M	P	S	T	U
	cm/in	cm/in	cm/in	cm/in	cm/in	cm/in	cm/in	cm/in	cm/in	cm/in	cm/in	cm/in	cm/in	cm/in
165	81/32	258/102	186/73	162/64	183/72	256/101	112/44	48/19	24/9	98/39	204/80	60/24	177/70	129/51
180	81/32	277/109	205/81	181/71	183/72	275/108	131/52	48/19	24/9	98/39	204/80	60/24	177/70	129/51
200	81/32	297/117	225/89	201/79	183/72	295/116	151/59	48/19	24/9	98/39	204/80	60/24	177/70	129/51

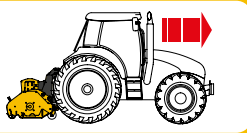

COMPETITION GS

AGRICULTURAL SERIES

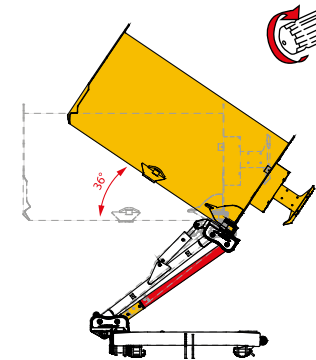

OLEOPNEUMATIC ANTI-SHOCK DEVICE (optional)
 In the event of meeting an obstruction, it protects the structural parts from potential breakages and accidental damage. As the head is forced back by the obstruction, some of the oil contained in the hydraulic cylinder of the machine transfers into the nitrogen pressurized accumulator which brings the machine back to working position once the obstacle has been passed

STRENGTH POINTS

<p>HARDOX® DOUBLE FRAME IN THE CUTTING AREA</p>	<p>3 ANNI DI GARANZIA SU I PARTICOLARI IN FUSIONE</p> <p>3 YEARS WARRANTY ON CAST IRON COMPONENT</p>	<p>ROUNDED FRAME AND CHAMFER ON THE OUTER EDGE OF HOOD</p>	<p>PROFESSIONAL REAR ROLLER Ø 140 mm with 4 taper roller bearings, mud scraper and central interchangeable body, with 2 positions: 1) self-cleaning 2) rear</p>	<p>"VENTILATOR" ROTOR electronically balanced, Forestry tool holders moulded in boron steel.</p>	<p>FREE-WHEEL IN GEARBOX</p>	<p>DOUBLE COUNTER KNIFE Increased rows of counter knives hold the material in for more complete shredding</p>	<p>AUTOMATIC BELTS TENSIONER The automatic tensioning system as well as allowing constant power transmission reduces belts wear</p>	<p>INTERNAL ROTOR BEARINGS The internal positioning of the bearings allows greater durability as it has greater protection from impacts and impurities</p>
--	---	---	--	---	-------------------------------------	---	---	--

COMPETITION GS		165	180	200
TECHNICAL SPECIFICATIONS				
Working width		162 cm / 64 in	181 cm / 71 cm	201 cm / 79 in
Machine weight		595 - 690 kg / 1312 - 1521 lb	630 - 730 kg / 1389 - 1609 lb	645 - 750 kg / 1422 - 1653 lb
tools	knives <i>optional</i> max Ø 3 cm	36	48	48
	hammers <i>standard</i> max Ø 5/6 cm kg1,35	12	16	16
rotor Ø	A	159 x 10 mm / 6 x 0,4 in	159 x 10 mm / 6 x 0,4 in	159 x 10 mm / 6 x 0,4 in
	B	423 mm / 16,7 in	423 mm / 16,7 in	423 mm / 16,7 in
N° Belts		4	4	4
CAT.		II	II	II
RPM PTO	540	Rotor revolutions / peripheral tool speed	2300 rpm - 50,9 m/sec	2300 rpm - 50,9 m/sec
HP max transmission		60 hp	60 hp	60 hp
Utilization		rear mounted		

TRACTOR REQUIREMENTS				
Minimum weight		2100 kg / 4630 lb	2200 kg / 4850 lb / 4850 lb	2400 kg / 5291 lb / 5291 lb
Minimum wheels setting		160 cm / 63 in	170 cm / 67 in	180 cm / 71 in

COMPETITION GS	165	180	200
MACHINE			
Extra side reach, up to 40 cm more off set	✓	✓	✓
Internal gearbox on top of hood	✓	✓	✓
Monocoque skin in Hardox®	✓	✓	✓
Hardox® double frame in the cutting area	✓	✓	✓
Rounded frame and chamfer on the outer end of hood	✓	✓	✓
Double counter knife	✓	✓	✓
Cast iron pivot points	✓	✓	✓
Main pivot point in cast iron	✓	✓	✓
Front safety flaps th. 6 mm	✓	✓	✓
Professional rear roller Ø 140 mm with 4 taper roller bearings, mud scraper and central interchangeable body, with 2 positions: 1) self-cleaning 2) rear	✓	✓	✓
Throwing adjustment of the shredded material	✓	✓	✓
Reflectors	✓	✓	✓
Side Skids in Hardox®	•	•	•
Protection chains	•	•	•
TRANSMISSION			
Wide angle cardan shaft 6 X 2150 1"3/8 Z6+1"3/8 Z6	✓	✓	✓
Tool holders - forestry type	✓	✓	✓
Ventilator rotor	✓	✓	✓
Tool screw in steel Ø 20 mm 12.9	✓	✓	✓
Oscillating bearings with double column of balls	✓	✓	✓
Free-wheel in gearbox	✓	✓	✓
Automatic belt tensioner	✓	✓	✓
Supplement for rotor with knife	•	•	•
SAFETY			
Oleopneumatic anti-shock device	•	•	•
HYDRAULIC SYSTEM			
Hydraulic side movement with adjustable ram and double acting anti-creep valve	✓	✓	✓
Hydraulic angling with safety tap for road transport	✓	✓	✓

COMPETITION GS

AGRICULTURAL SERIES

Self-cleaning roller position
unloading of mulched product behind the roller
for faster working speed

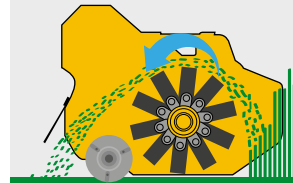

Rear roller position
unloading of mulched product in front of the
roller for better shredding



ROAD EDGES, DITCHES,
RIVER EDGES, PRUNINGS

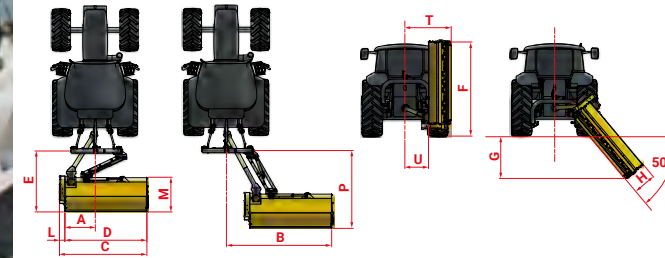

	A	B	C	D	E	F	G	H	L	M	P	S	T	U
	cm/in	cm/in	cm/in	cm/in	cm/in	cm/in	cm/in	cm/in	cm/in	cm/in	cm/in	cm/in	cm/in	cm/in
165	36/14	303/119	211/83	162/64	183/72	281/111	157/62	48/19	42/17	98/39	204/80	15/6	177/70	129/51
180	36/14	322/127	230/91	181/71	183/72	300/118	176/69	48/19	42/17	98/39	204/80	15/6	177/70	129/51
200	36/14	342/135	250/98	201/79	183/72	320/126	186/73	48/19	42/17	98/39	204/80	15/6	177/70	129/51



DIRECTION OF ROTATION OF P.T.O.

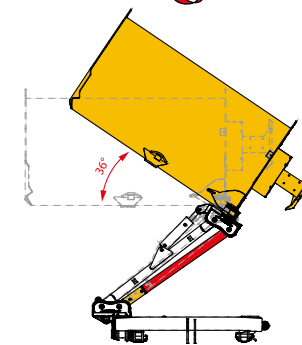

OLEOPNEUMATIC ANTI-SHOCK DEVICE (optional)

in the event of meeting an obstruction, it protects the structural parts from potential breakages and accidental damage. As the head is forced back by the obstruction, some of the oil contained in the hydraulic cylinder of the machine transfers into the nitrogen pressurized accumulator which brings the machine back to working position once the obstacle has been passed

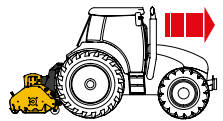

EXTRA REACH



COMPETITION GS OFF SET
AGRICULTURAL SERIES



50 - 80 HP



STRENGTH POINTS



HARDOX® DOUBLE FRAME IN THE CUTTING AREA



3 YEARS WARRANTY ON CAST IRON COMPONENT

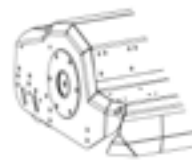

ROUNDED FRAME AND CHAMFER ON THE OUTER END OF HOOD



PROFESSIONAL REAR ROLLER
Ø 140 mm with 4 taper roller bearings, mud scraper and central interchangeable body, with 2 positions: 1) self-cleaning 2) rear



"VENTILATOR" ROTOR
electronically balanced, Forestry tool holders moulded in boron steel.

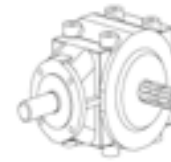

FREE-WHEEL IN GEARBOX



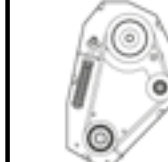

DOUBLE COUNTER KNIFE
Increased rows of counter knives hold the material in for more complete shredding

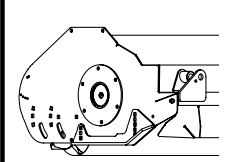

AUTOMATIC BELTS TENSIONER
The automatic tensioning system as well as allowing constant power transmission reduces belts wear



INTERNAL ROTOR BEARINGS
The internal positioning of the bearings allows greater durability as it has greater protection from impacts and impurities

COMPETITION GS OFF SET		165	180	200
TECHNICAL SPECIFICATIONS				
Working width		162 cm / 64 in	181 cm / 71 cm	201 cm / 79 in
Machine weight		620 - 715 kg / 1367- 1576 lb	655 - 755 kg / 1444 - 1664 lb	665 - 775 kg / 1466 - 1709lb
tools	 knives <i>optional</i> max Ø 3 cm	36	48	48
	 hammers <i>standard</i> max Ø 5/6 cm kg1,35	12	16	16
rotor Ø	A	159 x 10 mm / 6 x 0,4 in	159 x 10 mm / 6 x 0,4 in	159 x 10 mm / 6 x 0,4 in
	B	423 mm / 16,7 in	423 mm / 16,7 in	423 mm / 16,7 in
N° Belts		4	4	4
CAT.		II	II	II
540 RPM PTO	Rotor revolutions / peripheral tool speed	2300 rpm - 53,2 m/sec	2300 rpm - 53,2 m/sec	2300 rpm - 53,2 m/sec
HP max transmission		60 hp	60 hp	60 hp
Utilization		rear mounted		
TRACTOR REQUIREMENTS				
Minimum weight		2200 kg / 4850 lb	2300 kg / 5071 lb	2400 kg / 5291 lb
Minimum wheels setting		170 cm / 67 in	175 cm / 69 in	180 cm / 71 in
COMPETITION GS OFF SET		165	180	200
MACHINE				
Extra side reach, up to 40 cm more off set		✓	✓	✓
External gearbox on end of hood		✓	✓	✓
Hardox® double frame in the cutting area		✓	✓	✓
Rounded frame and chamfer on the outer end of hood		✓	✓	✓
Double counter knife		✓	✓	✓
Cast iron pivot points		✓	✓	✓
Main pivot point in cast iron		✓	✓	✓
Front safety flaps th. 6 mm		✓	✓	✓
Professional rear roller Ø 140 mm with 4 taper roller bearings, mud scraper and central interchangeable body, with 2 positions: 1) self-cleaning 2) rear		✓	✓	✓
Throwing adjustment of the shredded material		✓	✓	✓
Reflectors		✓	✓	✓
Side Skids in Hardox®		•	•	•
Protection chains		•	•	•
TRANSMISSION				
Wide angle cardan shaft 6 X 2150 1"3/8 Z6+1"3/8 Z6		✓	✓	✓
Tool holders - forestry type		✓	✓	✓
Ventilator rotor		✓	✓	✓
Tool screw in steel Ø 20 mm 12.9		✓	✓	✓
Oscillating bearings with double column of balls		✓	✓	✓
Free-wheel in gearbox		✓	✓	✓
Automatic belt tensioner		✓	✓	✓
Supplement for rotor with knife		•	•	•
SAFETY				
Oleopneumatic anti-shock device		•	•	•
HYDRAULIC SYSTEM				
Hydraulic side movement with adjustable ram and double acting anti-creep valve		✓	✓	✓
Hydraulic angling with safety tap for road transport		✓	✓	✓

COMPETITION GS

OFF SET AGRICULTURAL SERIES

Self-cleaning roller position
unloading of mulched product behind the roller for faster working speed

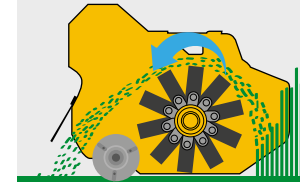

Rear roller position
unloading of mulched product in front of the roller for better shredding

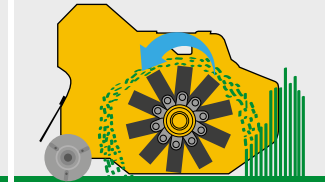

Optional
"smart safety"





EXTRA REACH

ROAD EDGES, DITCHES, RIVER EDGES, PRUNINGS

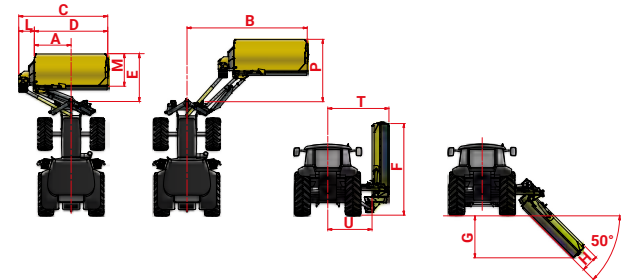

	A cm	B cm	C cm	D cm	E cm	F cm	G cm	H cm	L cm	M cm	P cm	T cm	U cm
165	50/20	298/117	205/81	162/64	226/89	275/108	157/62	48/19	43/17	99/39	225/89	180/71	130/51
180	50/20	317/125	224/88	181/71	226/89	295/116	176/69	48/19	43/17	99/39	225/89	180/71	130/51
200	50/20	337/133	244/96	201/79	226/89	314/124	186/73	48/19	43/17	99/39	225/89	180/71	130/51

HARDOX
IN MY BODY

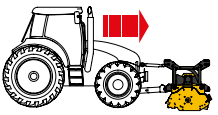

DIRECTION OF ROTATION OF P.T.O.

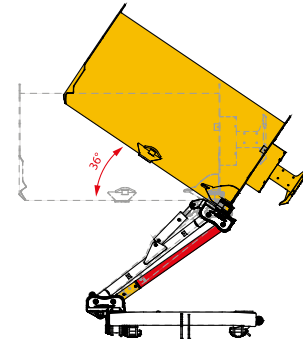

OLEOPNEUMATIC ANTI-SHOCK DEVICE (standard equipment)
In the event of meeting an obstruction, it protects the structural parts from potential breakages and accidental damage. As the head is forced back by the obstruction, some of the oil contained in the hydraulic cylinder of the machine transfers into the nitrogen pressurized accumulator which brings the machine back to working position once the obstacle has been passed

COMPETITION GS OFF SET FRONTAL
AGRICULTURAL SERIES



80 - 140 HP

THE BEST HAS A NAME
MORSI

STRENGTH POINTS



HARDOX® DOUBLE FRAME IN THE CUTTING AREA



3 YEARS WARRANTY ON CAST IRON COMPONENT

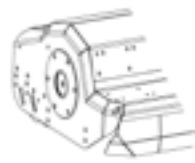

ROUNDED FRAME AND CHAMFER ON THE OUTER END OF HOOD



PROFESSIONAL REAR ROLLER
Ø 140 mm with 4 taper roller bearings, mud scraper and central interchangeable body, with 2 positions: 1) self-cleaning 2) rear



"VENTILATOR" ROTOR
electronically balanced, forestry tool holders moulded in boron steel.



FREE-WHEEL IN GEARBOX



DOUBLE COUNTER KNIFE
Increased rows of counter knives hold the material in for more complete shredding



AUTOMATIC BELTS TENSIONER
The automatic tensioning system as well as allowing constant power transmission reduces belts wear

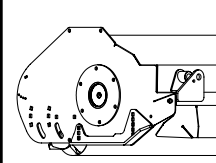

INTERNAL ROTOR BEARINGS
The internal positioning of the bearings allows greater durability as it has greater protection from impacts and impurities

COMPETITION GS OFF SET FRONTAL		165	180	200
TECHNICAL SPECIFICATIONS				
Working width		162 cm / 64 in	181 cm / 71 cm	201 cm / 79 in
Machine weight		735 - 770 kg / 1620 - 1698 lb	785 - 820 kg / 1731 - 1808 lb	815 - 850 kg / 1797 - 1874 lb
tools	 knives max Ø 3 cm	36	48	48
	 hammers max Ø 5/6 cm kg1,35	12	16	16
rotor Ø		A	159 x 10 mm / 6 x 0,4 in	159 x 10 mm / 6 x 0,4 in
		B	423 mm / 16,7 in	423 mm / 16,7 in
N° Belts		4	4	4
CAT.		II	II	II
1000 RPM PTO	Rotor revolutions / peripheral tool speed	2271 rpm - 50,3 m/sec	2271 rpm - 50,3 m/sec	2271 rpm - 50,3 m/sec
HP max transmission		120 hp	120 hp	120 hp
Utilization		front mounted		
TRACTOR REQUIREMENTS				
Minimum weight		2200 kg / 4850 lb	2300 kg / 5071 lb	2400 kg / 5291 lb
Minimum wheels setting		170 cm / 67 in	175 cm / 69 in	180 cm / 71 in

COMPETITION GS

OFF SET FRONTAL AGRICULTURAL SERIES

Self-cleaning roller position
unloading of mulched product behind the roller
for faster working speed

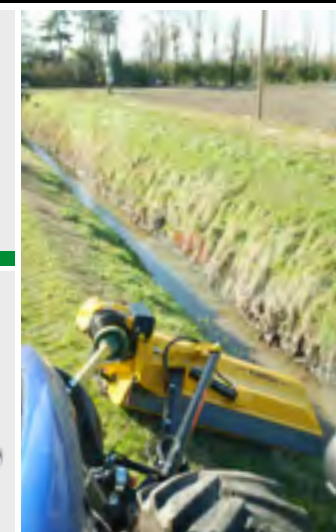
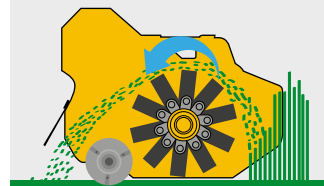

COMPETITION GS OFF SET FRONTAL	165	180	200
MACHINE			
Extra side reach, up to 40 cm more off set	✓	✓	✓
External gearbox on end of hood	✓	✓	✓
Hardox® double frame in the cutting area	✓	✓	✓
Monocoque skin in Hardox®	✓	✓	✓
Rounded frame and chamfer on the outer end of hood	✓	✓	✓
Double counter knife	✓	✓	✓
Front safety flaps th. 6 mm	✓	✓	✓
Professional rear roller Ø 140 mm with 4 taper roller bearings, mud scraper and central body interchangeable with 2 positions: 1) self-cleaning 2) rear	✓	✓	✓
Reflectors	✓	✓	✓
Side skids in Hardox®	•	•	•
Protection chains	•	•	•
TRANSMISSION			
Wide angle cardan shaft 6 X 2150 1"3/8 Z6+1"3/8 Z6	✓	✓	✓
Tool holders - forestry type	✓	✓	✓
Ventilator rotor	✓	✓	✓
Tool screw in steel Ø 20 mm 12.9	✓	✓	✓
Oscillating bearings with double column of balls	✓	✓	✓
Free-wheel in gearbox	✓	✓	✓
Automatic belt tensioner	✓	✓	✓
Supplement for rotor with knife	•	•	•
SAFETY			
Oleopneumatic anti-shock device	✓	✓	✓
HYDRAULIC SYSTEM			
Hydraulic side movement with adjustable ram and double acting anti-creep valve	✓	✓	✓
Hydraulic angling with safety tap for road transport	✓	✓	✓



✓ STANDARD EQUIPMENT | • OPTIONAL EQUIPMENT | - NOT AVAILABLE

ROAD EDGES, DITCHES,
RIVER EDGES, PRUNINGS

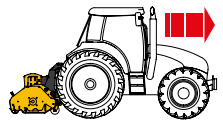

EXTRA
REACH



PRIMATIST GS

AGRICULTURAL SERIES



60 - 100 HP

THE BEST HAS A NAME
MORSI

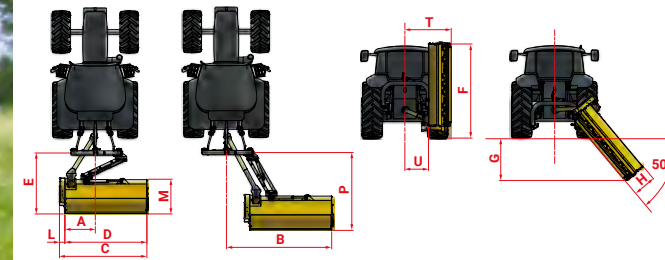

	A	B	C	D	E	F	G	H	L	M	P	S	T	U
	cm/in	cm/in	cm/in	cm/in	cm/in	cm/in	cm/in	cm/in	cm/in	cm/in	cm/in	cm/in	cm/in	cm/in
180	80/31	290/114	211/83	192/76	208/82	281/111	173/68	55/22	15/6	98/39	240/94	5/2	179/70	126/50
200	80/31	299/118	220/87	201/79	208/82	290/114	182/72	55/22	15/6	98/39	240/94	5/2	179/70	126/50
220	80/31	319/126	240/94	221/87	208/82	310/122	202/80	55/22	15/6	98/39	240/94	5/2	179/70	126/50
250	80/31	352/139	273/107	254/100	208/82	343/135	235/93	55/22	15/6	98/39	240/94	5/2	179/70	126/50



DIRECTION OF ROTATION OF P.T.O.

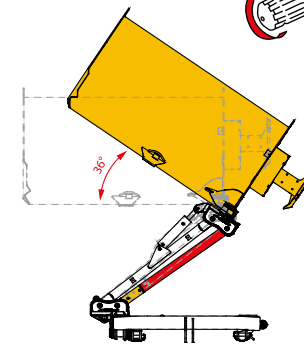

OLEOPNEUMATIC ANTI-SHOCK DEVICE (optional)

in the event of meeting an obstruction, it protects the structural parts from potential breakages and accidental damage. As the head is forced back by the obstruction, some of the oil contained in the hydraulic cylinder of the machine transfers into the nitrogen pressurized accumulator which brings the machine back to working position once the obstacle has been passed

STRENGTH POINTS



HARDOX® DOUBLE FRAME
IN THE CUTTING AREA



3 YEARS WARRANTY
ON CAST IRON COMPONENT

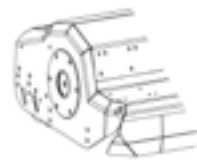

ROUNDED FRAME AND
CHAMFER ON THE OUTER END
OF HOOD



PROFESSIONAL REAR ROLLER
Ø 140 mm with 4 taper roller bearings,
mud scraper and central interchangeable
body, with 2 positions: 1) self-cleaning
2) rear



"VENTILATOR" ROTOR
electronically balanced, forestry tool
holders moulded in boron steel.

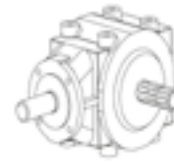

FREE-WHEEL IN GEARBOX



DOUBLE COUNTER KNIFE
Increased rows of counter knives hold
the material in for more complete
shredding



AUTOMATIC BELTS TENSIONER
The automatic tensioning system as well
as allowing constant power transmission
reduces belts wear

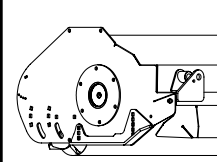

INTERNAL ROTOR BEARINGS
The internal positioning of the bearings
allows greater durability as it has greater
protection from impacts and impurities

PRIMATIST GS		180	200	220	250
TECHNICAL SPECIFICATIONS					
Working width		181 cm / 71 cm	201 cm / 79 in	221 cm / 87 cm	253 cm / 100 in
Machine weight		745 - 790 kg / 1642 - 1742 lb	765 - 808 kg / 1687 - 1781 lb	805 - 850 kg / 1775 - 1874 lb	855 - 900 kg / 1885 - 1984 lb
tools	knives max Ø 3 cm	48	48	48	60
	hammers max Ø 5/6 cm kg1,35	16	16	16	20
rotor Ø	A	159 x 10 mm / 6 x 0,4 in	159 x 10 mm / 6 x 0,4 in	178 x 10 mm / 7 x 0,4 in	178 x 10 mm / 7 x 0,4 in
	B	423 mm / 16,7 in	423 mm / 16,7 in	442 mm / 17 in	442 mm / 17 in
N° Belts Quad Power®		4	4	5	5
CAT.		II	II	II	II
540 RPM PTO	Rotor revolutions / peripheral tool speed	2300 rpm - 51 m/sec	2300 rpm - 51 m/sec	2050 rpm - 47,4 m/sec	2050 rpm - 47,4 m/sec
HP max transmission		70 hp	70 hp	70 hp	70 hp
Utilization		rear mounted			
TRACTOR REQUIREMENTS					
Minimum weight		2200 kg / 4850 lb	2400 kg / 5291 lb	2600 kg / 5732 lb	2800 kg / 6173 lb
Minimum wheels setting		170 cm / 67 in	180 cm / 71 in	200 cm / 79 in	220 cm / 87 in

PRIMATIST GS	180	200	220	250
MACHINE				
Extra side reach, up to 40 cm more off set	✓	✓	✓	✓
Internal gearbox on to of hood	✓	✓	✓	✓
Hardox® double frame in the cutting area	✓	✓	✓	✓
Rounded frame and chamfer on the outer end of hood	✓	✓	✓	✓
Double counter knife	✓	✓	✓	✓
Cast iron pivot points	✓	✓	✓	✓
Main pivot point in cast iron	✓	✓	✓	✓
Front safety flaps th. 6 mm	✓	✓	✓	✓
Professional rear roller Ø 140 mm with 4 taper roller bearings, mud scraper and central interchangeable body, with 2 positions: 1) self-cleaning 2) rear	✓	✓	✓	✓
Throwing adjustment of the shredded material	✓	✓	✓	✓
Reflectors	✓	✓	✓	✓
Side Skids in Hardox®	•	•	•	•
Protection chains	•	•	•	•
TRANSMISSION				
Wide angle cardan shaft	✓	✓	✓	✓
Tool holders - forestry type	✓	✓	✓	✓
Ventilator rotor	✓	✓	✓	✓
Double rotor support	-	-	✓	✓
Tool screw in steel Ø 20 mm 12.9	✓	✓	✓	✓
Oscillating bearings with double column of balls	✓	✓	✓	✓
Free-wheel in gearbox	✓	✓	✓	✓
Automatic belt tensioner	✓	✓	✓	✓
Supplement for rotor with knife	•	•	•	•
SAFETY				
Oleopneumatic anti-shock device	•	•	•	•
HYDRAULIC SYSTEM				
Hydraulic side movement with adjustable ram and double acting anti-creep valve	✓	✓	✓	✓
Hydraulic angleing with safety tap for road transport	✓	✓	✓	✓

PRIMATIST GS

AGRICULTURAL SERIES

Self-cleaning roller position
unloading of mulched product behind the roller for faster working speed

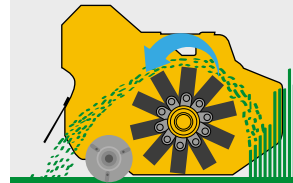

Rear roller position
unloading of mulched product in front of the roller for better shredding



Optional
"smart safety"



**ROAD EDGES, DITCHES,
RIVER EDGES, PRUNINGS**

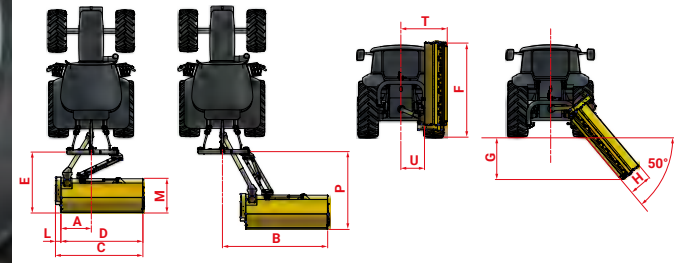

	A	B	C	D	E	F	G	H	L	M	P	S	T	U
	cm/in	cm/in	cm/in	cm/in	cm/in	cm/in	cm/in	cm/in	cm/in	cm/in	cm/in	cm/in	cm/in	cm/in
180	35/14	337/133	238/94	182/72	208/82	308/121	188/74	55/22	42/17	98/39	240/94	5/2	179/70	126/50
200	35/14	346/136	247/97	201/79	208/82	317/125	197/78	55/22	42/17	98/39	240/94	5/2	179/70	126/50
220	35/14	366/144	267/105	221/87	208/82	337/133	217/85	55/22	42/17	99/39	240/94	5/2	179/70	126/50
250	35/14	396/156	297/117	251/99	208/82	367/144	247/97	55/22	42/17	99/39	240/94	5/2	179/70	126/50

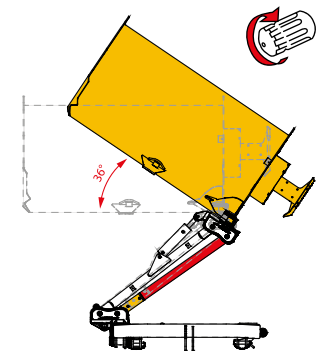

DIRECTION OF ROTATION OF P.T.O.

OLEOPNEUMATIC ANTI-SHOCK DEVICE (optional)
 in the event of meeting an obstruction, it protects the structural parts from potential breakages and accidental damage. As the head is forced back by the obstruction, some of the oil contained in the hydraulic cylinder of the machine transfers into the nitrogen pressurized accumulator which brings the machine back to working position once the obstacle has been passed

PRIMATIST GS OFF SET

AGRICULTURAL SERIES



60 - 100 HP



STRENGTH POINTS

<p>HARDOX® DOUBLE FRAME IN THE CUTTING AREA</p>	<p>3 ANNI DI GARANZIA SU I PARTICOLARI IN FUSIONE</p> <p>3 YEARS WARRANTY ON CAST IRON COMPONENT</p>	<p>ROUNDED FRAME AND CHAMFER ON THE OUTER END OF HOOD</p>	<p>PROFESSIONAL REAR ROLLER Ø 140 mm with 4 taper roller bearings, mud scraper and central interchangeable body, with 2 positions: 1) self-cleaning 2) rear</p>	<p>"VENTILATOR" ROTOR electronically balanced, Forestry tool holders moulded in boron steel.</p>	<p>DOUBLE ROTOR SUPPORT</p>	<p>DOUBLE COUNTER KNIFE Increased rows of counter knives hold the material in for more complete shredding</p>	<p>AUTOMATIC BELTS TENSIONER The automatic tensioning system as well as allowing constant power transmission reduces belts wear</p>	<p>INTERNAL ROTOR BEARINGS The internal positioning of the bearings allows greater durability as it has greater protection from impacts and impurities</p>
--	---	--	--	---	------------------------------------	---	---	--

PRIMATIST <i>GS OFF SET</i>	180	200	220	NEW 250
-----------------------------	-----	-----	-----	---------

TECHNICAL SPECIFICATIONS

Working width	181 cm / 71 cm	201 cm / 79 in	221 cm / 87 cm	253 cm / 100 in	
Machine weight	765 - 810 kg / 1687 - 1786 lb	785 - 828 kg / 1731 - 1825 lb	825 - 870 kg / 1819 - 1918 lb	875 - 920 kg / 1929 - 2028 lb	
tools	knives max Ø 3 cm	48	48	48	60
	hammers max Ø 5/6 cm kg1,35	16	16	16	20
rotor Ø	A	159 x 10 mm / 6 x 0,4 in	159 x 10 mm / 6 x 0,4 in	178 x 10 mm / 7 x 0,4 in	178 x 10 mm / 7 x 0,4 in
	B	423 mm / 16,7 in	423 mm / 16,7 in	442 mm / 17 in	442 mm / 17 in
N° Belts Quad Power®	4	4	5	5	
CAT.	II	II	II	II	
540 RPM PTO	Rotor revolutions / peripheral tool speed 2300 rpm - 51 m/sec		2050 rpm - 47,4 m/sec		
HP max transmission	70 hp	70 hp	70 hp	70 hp	
Utilization	rear mounted				

TRACTOR REQUIREMENTS

Minimum weight	2200 kg / 4850 lb	2400 kg / 5291 lb	2600 kg / 5732 lb	2800 kg / 6173 lb
Minimum wheels setting	170 cm / 67 in	180 cm / 71 in	200 cm / 79 in	220 cm / 87 in

PRIMATIST <i>GS OFF SET</i>	180	200	220	NEW 250
-----------------------------	-----	-----	-----	---------

MACHINE

Extra side reach, up to 40 cm more off set	✓	✓	✓	✓
External gearbox on end of hood	✓	✓	✓	✓
Monocoque skin in Hardox®	✓	✓	✓	✓
Hardox® double frame in the cutting area	✓	✓	✓	✓
Rounded frame and chamfer on the outer end of hood	✓	✓	✓	✓
Double counter knife	✓	✓	✓	✓
Cast iron pivot points	✓	✓	✓	✓
Main pivot point in cast iron	✓	✓	✓	✓
Front safety flaps th. 6 mm	✓	✓	✓	✓
Professional rear roller Ø 140 mm with 4 taper roller bearings, mud scraper and central interchangeable body, with 2 positions: 1) self-cleaning 2) rear	✓	✓	✓	✓
Throwing adjustment of the shredded material	✓	✓	✓	✓
Reflectors	✓	✓	✓	✓
Side Skids in Hardox®	•	•	•	•
Protection chains	•	•	•	•

TRANSMISSION

Wide angle cardan shaft	✓	✓	✓	✓
Tool holders - forestry type	✓	✓	✓	✓
Ventilator rotor	✓	✓	✓	✓
Double rotor support	-	-	✓	✓
Tool screw in steel Ø 20 mm 12.9	✓	✓	✓	✓
Oscillating bearings with double column of balls	✓	✓	✓	✓
Free-wheel in gearbox	✓	✓	✓	✓
Automatic belt tensioner	✓	✓	✓	✓
Supplement for rotor with knife	•	•	•	•

SAFETY

Oleopneumatic anti-shock device	•	•	•	•
---------------------------------	---	---	---	---

HYDRAULIC SYSTEM

Hydraulic side movement with adjustable ram and double acting anti-creep valve	✓	✓	✓	✓
Hydraulic angling with safety tap for road transport	✓	✓	✓	✓

PRIMATIST *GS OFF SET*

AGRICULTURAL SERIES

Self-cleaning roller position
unloading of mulched product behind the roller for faster working speed

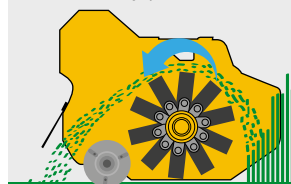

Rear roller position
unloading of mulched product in front of the roller for better shredding

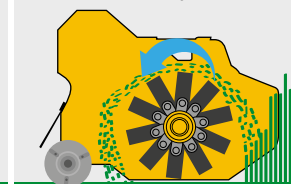

Optional
"smart safety"





**ROAD EDGES, DITCHES,
RIVER EDGES, PRUNINGS**

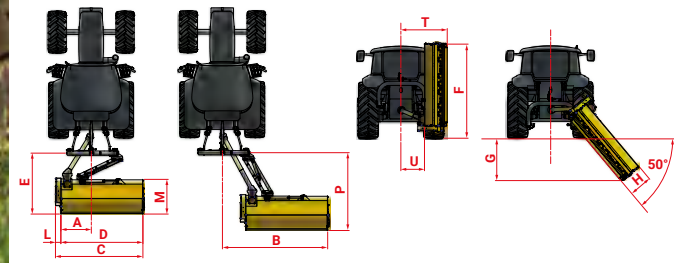

	A	B	C	D	E	F	G	H	L	M	P	S	T	U
	cm/in	cm/in	cm/in	cm/in	cm/in	cm/in	cm/in	cm/in	cm/in	cm/in	cm/in	cm/in	cm/in	cm/in
185	80/31	290/114	211/83	182/72	218/86	281/111	173/68	55/22	15/6	107/42	250/98	5/2	179/70	126/50
200	80/31	299/118	220/87	201/79	218/86	290/114	182/72	55/22	15/6	107/42	250/98	5/2	179/70	126/50
220	80/31	319/126	240/94	221/87	218/86	310/122	202/80	55/22	15/6	107/42	250/98	5/2	179/70	126/50
260	80/31	351/136	272/107	251/99	218/86	342/135	230/91	55/22	15/6	107/42	250/98	5/2	179/70	126/50



EXTRA REACH

HARDOX
IN MY BODY

PRIMATIST PLUS GS
AGRICULTURAL SERIES



70 - 140 HP

THE BEST HAS A NAME
MORSI



DIRECTION OF ROTATION OF P.T.O.

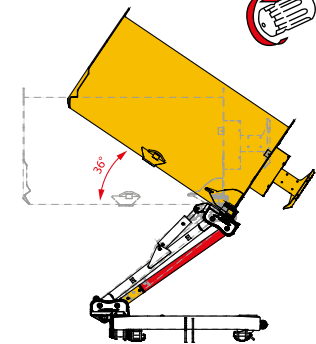

OLEOPNEUMATIC ANTI-SHOCK DEVICE (optional)
in the event of meeting an obstruction, it protects the structural parts from potential breakages and accidental damage. As the head is forced back by the obstruction, some of the oil contained in the hydraulic cylinder of the machine transfers into the nitrogen pressurized accumulator which brings the machine back to working position once the obstacle has been passed

STRENGTH POINTS

<p>HARDOX® DOUBLE FRAME IN THE CUTTING AREA</p>	<p>3 ANNI DI GARANZIA SUI PARTICOLARI IN FUSIONE</p> <p>3 YEARS WARRANTY ON CAST IRON COMPONENT</p>	<p>ROUNDED FRAME AND CHAMFER ON THE OUTER END OF HOOD</p>	<p>PROFESSIONAL REAR ROLLER Ø 194 mm with 4 taper roller bearings, mud scraper and central interchangeable body, with 2 positions: 1) self-cleaning 2) rear</p>	<p>"VENTILATOR" ROTOR electronically balanced, Forestry tool holders moulded in boron steel.</p>	<p>DOUBLE ROTOR SUPPORT</p>	<p>DOUBLE COUNTER KNIFE Increased rows of counter knives hold the material in for more complete shredding</p>	<p>AUTOMATIC BELTS TENSIONER The automatic tensioning system as well as allowing constant power transmission reduces belts wear</p>	<p>INTERNAL ROTOR BEARINGS The internal positioning of the bearings allows greater durability as it has greater protection from impacts and impurities</p>
--	---	--	--	---	------------------------------------	--	--	---

PRIMATIST PLUS GS	185	200	220	260
-------------------	-----	-----	-----	-----

TECHNICAL SPECIFICATIONS

Working width	181 cm / 71 cm	201 cm / 79 in	221 cm / 87 cm	253 cm / 100 in
Machine weight	840 - 890 kg / 1852 - 1962 lb	860 - 910 kg / 1896 - 2006 lb	900 - 960 kg / 1984 - 2116 lb	950 - 1010 kg / 2094 - 2227 lb
tools	knives max Ø 3,5 cm	48	48	60
	hammers max Ø 5/6 cm kg1,7	16	16	20
rotor Ø	A	178 x 10 mm / 7 x 0,4 in	178 x 10 mm / 7 x 0,4 in	194 x 10 mm / 8 x 0,4 in
	B	441 mm / 17 in	441 mm / 17 in	458 mm / 18 in
N° Belts Quad Power®	4	4	5	5
CAT.	II	II	II	II
540 RPM PTO	2300 rpm - 53,1 m/sec	2300 rpm - 53,1 m/sec	2025 rpm - 48,5 m/sec	2025 rpm - 48,5 m/sec
HP max transmission	80 hp	80 hp	110 hp	110 hp

Utilization rear mounted

TRACTOR REQUIREMENTS

Minimum weight	2750 kg / 6063 lb	2950 kg / 6504 lb	3200 kg / 7055 lb	3400 kg / 7496 lb
Minimum wheels setting	180 cm / 71 in	200 cm / 79 in	220 cm / 87 in	220 cm / 87 in

PRIMATIST PLUS GS

MACHINE

	185	200	220	260
Extra side reach, up to 40 cm more off set	✓	✓	✓	✓
Internal gearbox on top of hood	✓	✓	✓	✓
Double skin in Hardox®	✓	✓	✓	✓
Cast iron pivot points	✓	✓	✓	✓
Double counter knife	✓	✓	✓	✓
Rounded frame and chamfer on the outer end of hood	✓	✓	✓	✓
Main pivot point in cast iron	✓	✓	✓	✓
Front safety flaps th. 6 mm	✓	✓	✓	✓
Professional rear roller Ø 194 mm with 4 taper roller bearings, mud scraper and central interchangeable body, with 2 positions: 1) self-cleaning 2) rear	✓	✓	✓	✓
Throwing adjustment of the shredded material	✓	✓	✓	✓
Reflectors	✓	✓	✓	✓
Side Skids in Hardox®	•	•	•	•
Catene di protezione	•	•	•	•

TRANSMISSION

Wide angle cardan shaft	✓	✓	✓	✓
Tool holders - forestry type	✓	✓	✓	✓
Ventilator rotor	✓	✓	✓	✓
Double rotor support	✓	✓	✓	✓
Tool screw in steel Ø 20 mm 12.9	✓	✓	✓	✓
Oscillating bearings with double column of balls	✓	✓	✓	✓
Free-wheel in gearbox	✓	✓	✓	✓
Automatic belt tensioner	✓	✓	✓	✓
Gear box 130 HP	-	-	•	•
Supplement for rotor with knife	•	•	•	•

SAFETY

Mechanical safety and self-leveling system with double extra linkage	✓	✓	✓	✓
Oleopneumatic anti-shock device	•	•	•	•

HYDRAULIC SYSTEM

Hydraulic side movement with adjustable ram and double acting anti-creep valve	✓	✓	✓	✓
Hydraulic angling with safety tap for road transport	✓	✓	✓	✓

PRIMATIST PLUS GS

AGRICULTURAL SERIES

Self-cleaning roller position
unloading of mulched product behind the roller for faster working speed

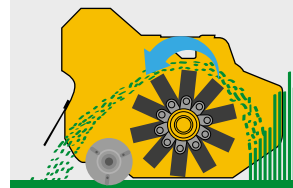

Rear roller position
unloading of mulched product in front of the roller for better shredding

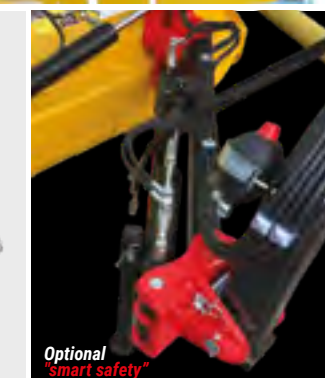
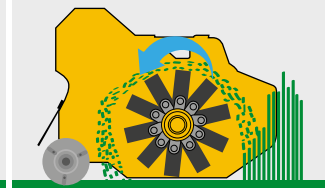

Optional
"Smart safety"

ROAD EDGES, DITCHES,
RIVER EDGES, PRUNINGS

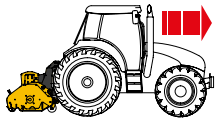

EXTRA
REACH



HARDOX®
IN MY BODY

PRIMATIST **PLUS GS** OFF SET

AGRICULTURAL SERIES



70 - 140 HP

THE BEST HAS A NAME
MORSI

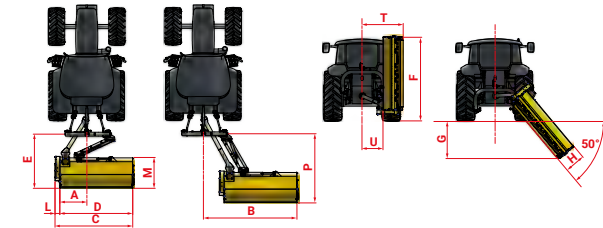

	A	B	C	D	E	F	G	H	L	M	P	S	T	U
	cm/in	cm/in	cm/in	cm/in	cm/in	cm/in	cm/in	cm/in	cm/in	cm/in	cm/in	cm/in	cm/in	cm/in
185	35/14	337/133	238/94	182/72	218/86	308/121	188/74	55/22	42/17	107/42	250/98	5/2	179/70	126/50
200	35/14	346/136	247/97	201/79	218/86	317/125	197/78	55/22	42/17	107/42	250/98	5/2	179/70	126/50
220	35/14	366/144	267/105	221/87	218/86	337/133	217/85	55/22	42/17	107/42	250/98	5/2	179/70	126/50

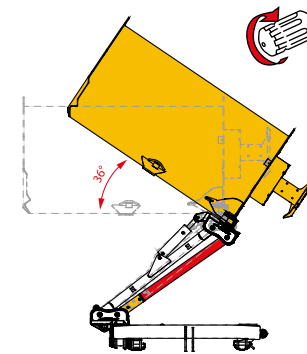

DIRECTION OF ROTATION OF P.T.O.

OLEOPNEUMATIC ANTI-SHOCK DEVICE (optional)

in the event of meeting an obstruction, it protects the structural parts from potential breakages and accidental damage. As the head is forced back by the obstruction, some of the oil contained in the hydraulic cylinder of the machine transfers into the nitrogen pressurized accumulator which brings the machine back to working position once the obstacle has been passed

STRENGTH POINTS



HARDOX® DOUBLE FRAME IN THE CUTTING AREA



3 YEARS WARRANTY ON CAST IRON COMPONENT

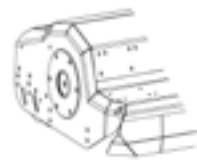

ROUNDED FRAME AND CHAMFER ON THE OUTER END OF HOOD



PROFESSIONAL REAR ROLLER
Ø 194 mm with 4 taper roller bearings, mud scraper and central interchangeable body, with 2 positions: 1) self-cleaning 2) rear



"VENTILATOR" ROTOR
electronically balanced, forestry tool holders moulded in boron steel.



DOUBLE ROTOR SUPPORT



DOUBLE COUNTER KNIFE
Increased rows of counter knives hold the material in for more complete shredding



AUTOMATIC BELTS TENSIONER
The automatic tensioning system as well as allowing constant power transmission reduces belts wear

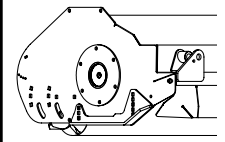

INTERNAL ROTOR BEARINGS
The internal positioning of the bearings allows greater durability as it has greater protection from impacts and impurities

PRIMATIST PLUS GS OFF SET	185	200	220
---------------------------	-----	-----	-----

TECHNICAL SPECIFICATIONS

Working width	181 cm / 71 cm	201 cm / 79 in	221 cm / 87 cm
Machine weight	855 - 895 kg / 1885 - 1973 lb	885 - 930 kg / 1951 - 2050 lb	915 - 960 kg / 2017 - 2116 lb
Tools	knives max Ø 3,5 cm	48	60
	hammers max Ø 5/6 cm kg 1,7	16	20
Rotor Ø	A	178 x 10 mm / 7 x 0,4 in	178 x 10 mm / 7 x 0,4 in
	B	441 mm / 17 in	441 mm / 17 in
N° Belts Quad Power®	4	4	5
CAT.	II	II	II
RPM PTO	540		
	Rotor revolutions / peripheral tool speed	2300 rpm - 53,1 m/sec	2300 rpm - 53,1 m/sec
HP max transmission	80 hp	80 hp	110 hp
Utilization	rear mounted		

TRACTOR REQUIREMENTS

Minimum weight	2900 kg / 6393 lb	3100 kg / 6834 lb	3350 kg / 7385 lb
Minimum wheels setting	190 cm / 75 in	210 cm / 83 in	220 cm / 87 in

PRIMATIST PLUS GS OFF SET	185	200	220
---------------------------	-----	-----	-----

MACCHINA

Extra side reach, up to 40 cm more off set	✓	✓	✓
External gearbox on end of hood	✓	✓	✓
Double skin in Hardox®	✓	✓	✓
Cast iron pivot points	✓	✓	✓
Double counter knife	✓	✓	✓
Rounded frame and chamfer on the outer end of hood	✓	✓	✓
Main pivot point in cast iron	✓	✓	✓
Front safety flaps th. 6 mm	✓	✓	✓
Professional rear roller Ø 194 mm with 4 taper roller bearings, mud scraper and central interchangeable body, with 2 positions: 1) self-cleaning 2) rear	✓	✓	✓
Throwing adjustment of the shredded material	✓	✓	✓
Reflectors	✓	✓	✓
Side Skids in Hardox®	•	•	•
Protection chains	•	•	•

TRANSMISSION

Wide angle cardan shaft	✓	✓	✓
Tool holders - forestry type	✓	✓	✓
Ventilator rotor	✓	✓	✓
Double rotor support	✓	✓	✓
Tool screw in steel Ø 20 mm 12.9	✓	✓	✓
Oscillating bearings with double column of balls	✓	✓	✓
Free-wheel in gearbox	✓	✓	✓
Automatic belt tensioner	✓	✓	✓
Gear box 130 HP	-	-	•
Supplement for rotor with knife	•	•	•

SAFETY

Mechanical safety and self-leveling system with double extra linkage	✓	✓	✓
Oleopneumatic anti-shock device	•	•	•

HYDRAULIC SYSTEM

Hydraulic side movement with adjustable ram and double acting anti-creep valve	✓	✓	✓
Hydraulic angling with safety tap for road transport	✓	✓	✓

PRIMATIST PLUS GS

OFF SET AGRICULTURAL SERIES

Self-cleaning roller position
unloading of mulched product behind the roller for faster working speed

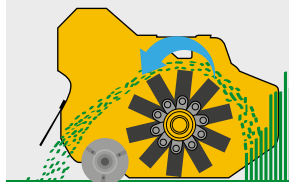

Rear roller position
unloading of mulched product in front of the roller for better shredding

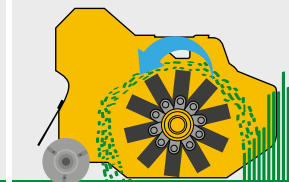

Optional
"Smart safety"

ROAD EDGES, DITCHES,
RIVER EDGES, PRUNINGS

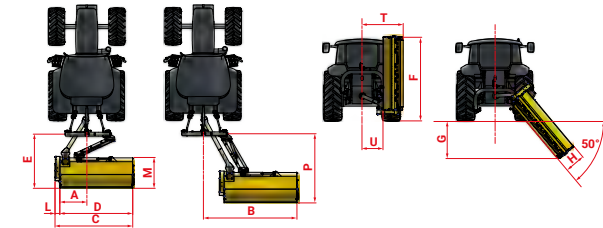

	A	B	C	D	E	F	G	H	L	M	P	S	T	U
	cm/in	cm/in	cm/in	cm/in	cm/in	cm/in	cm/in	cm/in	cm/in	cm/in	cm/in	cm/in	cm/in	cm/in
185	93/37	265/104	198/78	181/71	209/82	268/106	160/63	54/21	17/7	105/41	259/102	70/28	168/66	114/45
210	93/37	285/112	218/86	201/79	209/82	288/113	180/71	54/21	17/7	105/41	259/102	70/28	168/66	114/45
235	93/37	312/123	245/96	228/90	209/82	315/124	207/81	54/21	17/7	105/41	259/102	70/28	168/66	114/45
250	93/37	335/132	268/106	251/99	209/82	338/133	230/91	54/21	17/7	105/41	259/102	70/28	168/66	114/45

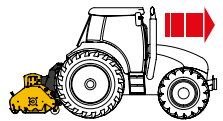
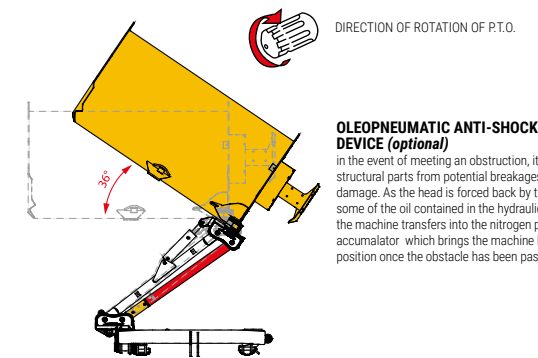

EXTRA
REACH

MAGNUM PLUS GS

PROFESSIONAL SERIES



80 - 200 HP

THE BEST HAS A NAME
MORSI

STRENGTH POINTS



DOUBLE SKIN IN HARDOX®



3 YEARS WARRANTY
ON CAST IRON COMPONENT

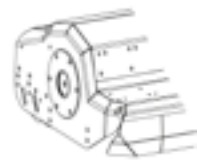

ROUNDED FRAME AND
CHAMFER ON THE OUTER END
OF HOOD



PROFESSIONAL REAR ROLLER
Ø 194 mm with 4 taper roller bearings,
mud scraper and central interchangeable
body, with 2 positions: 1) self-cleaning
2) rear



"VENTILATOR" ROTOR
electronically balanced. Forestry tool
holders moulded in boron steel.



DOUBLE ROTOR SUPPORT



DOUBLE COUNTER KNIFE
Increased rows of counter knives hold the
material in for more complete shredding



AUTOMATIC BELTS TENSIONER
The automatic tensioning system as well
as allowing constant power transmission
reduces belts wear.



EXTERNAL ROTOR SUPPORT
IN PRESSED STEEL
The external rotor support allows the easy
dismantling / replacement of the rotor and
/ or the bearings

MAGNUM PLUS GS		185	210	235	250
Working width		181 cm / 71 cm	201 cm / 79 in	228 cm / 90 in	251 cm / 99 in
Machine weight		1080 - 1130 kg / 2381 - 2491 lb	1110 - 1160 kg / 2447 - 2557 lb	1150 - 1200 kg / 2535 - 2646 lb	1175 - 1225 kg / 2590 - 2701 lb
tools	knives max Ø 3,5 cm	48	48	60	60
	hammers max Ø 8 cm kg 2,1	16	16	20	20
rotor Ø	A	194 x 12.5 mm / 8 x 0.5 in	194 x 12.5 mm / 8 x 0.5 in	194 x 12.5 mm / 8 x 0.5 in	194 x 12.5 mm / 8 x 0.5 in
	B	452 mm / 18 in	452 mm / 18 in	452 mm / 18 in	452 mm / 18 in
N° Belts Quad Power®		4	4	5	5
CAT.		II-III	II-III	II-III	II-III
540 RPM PTO	Rotor revolutions / peripheral tool speed	2250 rpm - 53,2 m/sec	2250 rpm - 53,2 m/sec	2250 rpm - 53,2 m/sec	2025 rpm - 47,9 m/sec
HP max transmission		100 hp	100 hp	110 hp	110 hp
Utilization		rear mounted			

TRACTOR REQUIREMENTS

Minimum weight	3200 kg / 7055 lb	3500 kg / 7716 lb	3800 kg / 8378 lb	4000 kg / 8818 lb
Minimum wheels setting	220 cm / 87 in	220 cm / 87 in	220 cm / 87 in	220 cm / 87 in

MAGNUM PLUS GS	185	210	235	250
----------------	-----	-----	-----	-----

MACHINE

Extra side reach, up to 40 cm more off set	✓	✓	✓	✓
Internal gearbox on top of hood				
Double skin in Hardox®	✓	✓	✓	✓
Rounded frame and chamfer on the outer end of hood	✓	✓	✓	✓
Double counter knife	✓	✓	✓	✓
Cast iron pivot points	✓	✓	✓	✓
Main pivot point in cast iron	✓	✓	✓	✓
Front safety flaps th. 6 mm	✓	✓	✓	✓
Professional rear roller Ø 194 mm with 4 taper roller bearings, mud scraper and central interchangeable body, with 2 positions: 1) self-cleaning 2) rear	✓	✓	✓	✓
Throwing adjustment of the shredded material	✓	✓	✓	✓
Reflectors	✓	✓	✓	✓
Side Skids in Hardox®	•	•	•	•
Protection chains	•	•	•	•

TRANSMISSION

Wide angle cardan shaft	✓	✓	✓	✓
Tool holders - forestry type	✓	✓	✓	✓
Ventilator rotor	✓	✓	✓	✓
Double rotor support	-	-	✓	✓
Tool screw in steel Ø 20 mm 12.9	✓	✓	✓	✓
Oscillating bearings with double column of balls	✓	✓	✓	✓
Free-wheel in gearbox	✓	✓	✓	✓
Automatic belt tensioner	✓	✓	✓	✓
Gear box 130 HP	•	•	•	•
Supplement for rotor with knife	•	•	•	•

SAFETY

Mechanical safety and self-leveling system with double extra linkage	✓	✓	✓	✓
Oleopneumatic anti-shock device	•	•	•	•

HYDRAULIC SYSTEM

Hydraulic side movement with adjustable ram and double acting anti-creep valve	✓	✓	✓	✓
Hydraulic angling with safety tap for road transport	✓	✓	✓	✓

MAGNUM PLUS GS

PROFESSIONAL SERIES

Self-cleaning roller position
unloading of mulched product behind the roller for faster working speed

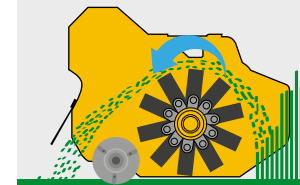

Rear roller position
unloading of mulched product in front of the roller for better shredding

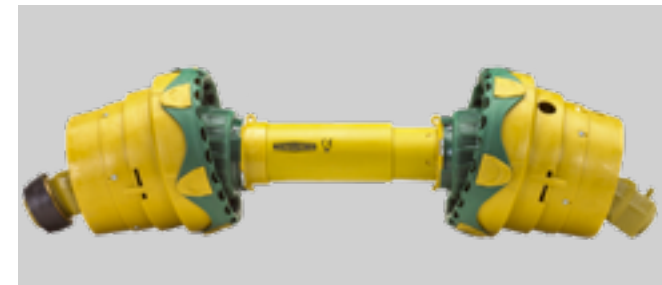

**ROAD EDGES, DITCHES,
RIVER EDGES, PRUNINGS**

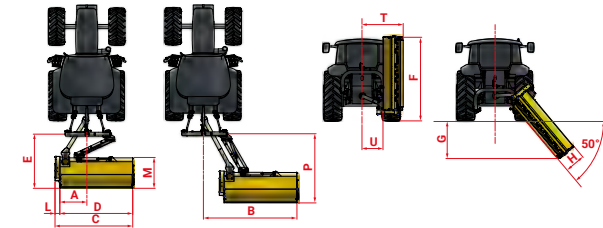

	A	B	C	D	E	F	G	H	L	M	P	S	T	U
	cm/in	cm/in	cm/in	cm/in	cm/in	cm/in	cm/in	cm/in	cm/in	cm/in	cm/in	cm/in	cm/in	cm/in
185	47/19	312/123	228/90	181/71	209/82	298/117	175/69	54/21	45/18	105/41	259/102	24/9	168/66	114/45
210	47/19	332/131	248/98	201/79	209/82	318/125	195/77	54/21	45/18	105/41	259/102	24/9	168/66	114/45
235	47/19	359/141	275/108	228/90	209/82	345/136	222/87	54/21	45/18	105/41	259/102	24/9	168/66	114/45
250	47/19	382/150	298/117	251/99	209/82	368/145	245/96	54/21	45/18	105/41	259/102	24/9	168/66	114/45

HARDOX
IN MY BODY

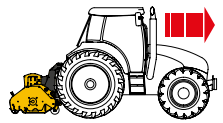

EXTRA REACH

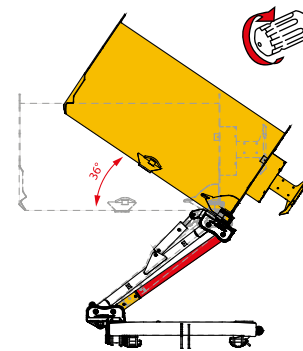

DIRECTION OF ROTATION OF P.T.O.

OLEOPNEUMATIC ANTI-SHOCK DEVICE (optional)

In the event of meeting an obstruction, it protects the structural parts from potential breakages and accidental damage. As the head is forced back by the obstruction, some of the oil contained in the hydraulic cylinder of the machine transfers into the nitrogen pressurized accumulator which brings the machine back to working position once the obstacle has been passed

MAGNUM PLUS GS OFF SET
PROFESSIONAL SERIES



80 - 200 HP



STRENGTH POINTS



DOUBLE SKIN IN HARDOX®



3 YEARS WARRANTY ON CAST IRON COMPONENT
SUI PARTICOLARI IN FUSIONE

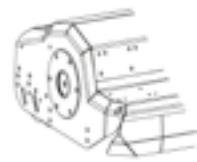

ROUNDED FRAME AND CHAMFER ON THE OUTER END OF HOOD



PROFESSIONAL REAR ROLLER Ø 194 mm with 4 taper roller bearings, mud scraper and central interchangeable body, with 2 positions: 1) self-cleaning 2) rear



"VENTILATOR" ROTOR electronically balanced. Forestry tool holders moulded in boron steel.



DOUBLE ROTOR SUPPORT



DOUBLE COUNTER KNIFE Increased rows of counter knives hold the material in for more complete shredding



AUTOMATIC BELTS TENSIONER The automatic tensioning system as well as allowing constant power transmission reduces belts wear.



EXTERNAL ROTOR SUPPORT IN PRESSED STEEL The external rotor support allows the easy dismantling / replacement of the rotor and / or the bearings

MAGNUM PLUS GS OFF SET	185	210	235	250
------------------------	-----	-----	-----	-----

TECHNICAL SPECIFICATIONS

Working width	181 cm / 71 cm	201 cm / 79 in	228 cm / 90 in	251 cm / 99 in	
Machine weight	1090 - 1140 kg	1120 - 1170 kg	1160 - 1210 kg	1185 - 1235 kg	
tools	knives max Ø 3,5 cm	48	48	60	60
	hammers max Ø 8 cm - kg 2,1	16	16	20	20
rotor Ø	A	194 x 12.5 mm / 8 x 0.5 in	194 x 12.5 mm / 8 x 0.5 in	194 x 12.5 mm / 8 x 0.5 in	194 x 12.5 mm / 8 x 0.5 in
	B	452 mm / 18 in	452 mm / 18 in	452 mm / 18 in	452 mm / 18 in
N° Belts Quad Power®	4	4	5	5	
CAT.	II-III	II-III	II-III	II-III	
540 RPM PTO	Rotor revolutions / peripheral tool speed	2250 rpm - 53,2 m/sec	2250 rpm - 53,2 m/sec	2250 rpm - 53,2 m/sec	2025 rpm - 47,9 m/sec
HP max transmission	110 hp	110 hp	110 hp	110 hp	
Utilization	rear mounted				

TRACTOR REQUIREMENTS

Minimum weight	3200 kg / 7055 lb	3500 kg / 7716 lb	3800 kg / 8378 lb	4100 kg / 9039 lb
Minimum wheels setting	220 cm / 87 in	220 cm / 87 in	220 cm / 87 in	220 cm / 87 in

MAGNUM PLUS GS OFF SET

	185	210	235	250
MACHINE				
Extra side reach, up to 40 cm more off set	✓	✓	✓	✓
External gearbox on end of hood	✓	✓	✓	✓
Double skin in Hardox®	✓	✓	✓	✓
Cast iron pivot points	✓	✓	✓	✓
Double counter knife	✓	✓	✓	✓
Rounded frame and chamfer on the outer end of hood	✓	✓	✓	✓
Main pivot point in cast iron	✓	✓	✓	✓
Front safety flaps th. 6 mm	✓	✓	✓	✓
Professional rear roller Ø 194 mm with 4 taper roller bearings, mud scraper and central interchangeable body, with 2 positions: 1) self-cleaning 2) rear	✓	✓	✓	✓
Throwing adjustment of the shredded material	✓	✓	✓	✓
Catarifrangenti	✓	✓	✓	✓
Side Skids in Hardox®	•	•	•	•
Protection chains	•	•	•	•
TRANSMISSION				
Wide angle cardan shaft	✓	✓	✓	✓
Tool holders - forestry type	✓	✓	✓	✓
Ventilator rotor	✓	✓	✓	✓
Double rotor support	-	-	✓	✓
Tool screw in steel Ø 20 mm 12.9	✓	✓	✓	✓
Oscillating bearings with double column of balls	✓	✓	✓	✓
Free-wheel in gearbox	✓	✓	✓	✓
Automatic belt tensioner	✓	✓	✓	✓
Gear box 130 HP	•	•	•	•
Supplemento montaggio coltelli	•	•	•	•
SAFETY				
Mechanical safety and self-leveling system with double extra linkage	✓	✓	✓	✓
Oleopneumatic anti-shock device	•	•	•	•
HYDRAULIC SYSTEM				
Hydraulic side movement with adjustable ram and double acting anti-creep valve	✓	✓	✓	✓
Hydraulic angling with safety tap for road transport	✓	✓	✓	✓

✓ STANDARD EQUIPMENT | • OPTIONAL EQUIPMENT | - NOT AVAILABLE

MAGNUM PLUS GS

OFF SET PROFESSIONAL SERIES

Self-cleaning roller position
unloading of mulched product behind the roller for faster working speed

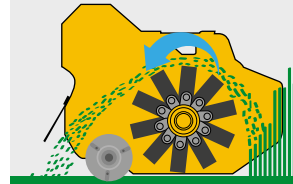

Rear roller position
unloading of mulched product in front of the roller for better shredding

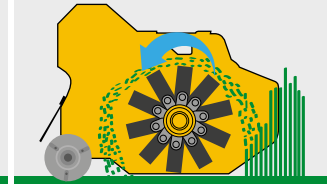



**ROAD EDGES, DITCHES,
RIVER EDGES, PRUNINGS**

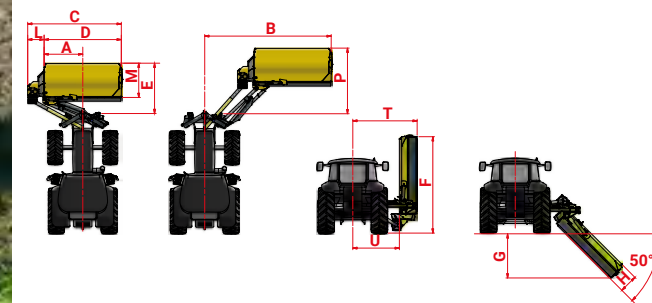

	A	B	C	D	E	F	G	H	L	M	P	T	U
	cm/in	cm/in	cm/in	cm/in	cm/in	cm/in	cm/in	cm/in	cm/in	cm/in	cm/in	cm/in	cm/in
185	54/21	312/123	232/91	181/71	248/98	302/119	175/69	54/21	50/20	102/40	227/89	198/78	144/57
235	54/21	359/141	279/110	228/90	248/98	349/137	222/87	54/21	50/20	102/40	259/89	198/78	144/57

EXTRA REACH



HARDOX
IN MY BODY

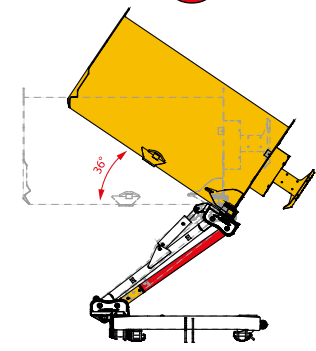

OLEOPNEUMATIC ANTI-SHOCK DEVICE (standard equipment)
in the event of meeting an obstruction, it protects the structural parts from potential breakages and accidental damage. As the head is forced back by the obstruction, some of the oil contained in the hydraulic cylinder of the machine transfers into the nitrogen pressurized accumulator which brings the machine back to working position once the obstacle has been passed

MAGNUM PLUS GS OFF SET FRONTAL
PROFESSIONAL SERIES



100 - 180 HP

THE BEST HAS A NAME
MORSI

STRENGTH POINTS

<p>DOUBLE SKIN IN HARDOX®</p>	<p>3 ANNI DI GARANZIA SUI PARTICOLARI IN FUSIONE</p> <p>3 YEARS WARRANTY ON CAST IRON COMPONENT</p>	<p>ROUNDED FRAME AND CHAMFER ON THE OUTER END OF HOOD</p>	<p>PROFESSIONAL REAR ROLLER Ø 194 mm with 4 taper roller bearings, mud scraper and central interchangeable body, with 2 positions: 1) self-cleaning 2) rear</p>	<p>"VENTILATOR" ROTOR electronically balanced. Forestry tool holders moulded in boron steel.</p>	<p>DOUBLE ROTOR SUPPORT</p>	<p>DOUBLE COUNTER KNIFE Increased rows of counter knives hold the material in for more complete shredding</p>	<p>AUTOMATIC BELTS TENSIONER The automatic tensioning system as well as allowing constant power transmission reduces belts wear.</p>	<p>EXTERNAL ROTOR SUPPORT IN PRESSED STEEL The external rotor support allows the easy dismantling / replacement of the rotor and / or the bearings</p>
--------------------------------------	---	--	--	---	------------------------------------	--	---	---

MAGNUM PLUS GS OFF SET FRONTAL	185	235
--------------------------------	-----	-----

TECHNICAL SPECIFICATIONS

Working width	181 cm / 71 in	228 cm / 90 in	
Machine weight	1060 - 1165 kg / 2337 - 2568 lb	1165 - 1270 kg / 2337 - 2568 lb	
Tools	knives max Ø 3,5 cm	48	60
	hammers max Ø 8 cm kg 2,1	16	20
Rotor Ø	A	194 x 12.5 mm / 8 x 0.5 in	194 x 12.5 mm / 8 x 0.5 in
	B	452 mm / 18 in	452 mm / 18 in
N° Belts Quad Power®	4	5	
CAT.	II	II	
1000 RPM PTO	Rotor revolutions / peripheral tool speed	2250 rpm - 53,25 m/sec	2250 rpm - 53,25 m/sec
HP max transmission	160 hp	160 hp	
Utilization	front mounted		

TRACTOR REQUIREMENTS

Minimum weight	5500 kg / 12125 lb	6000 kg / 6000 lb
Minimum wheels setting	220 cm / 87 in	230 cm / 91 in

MAGNUM PLUS GS OFF SET FRONTAL	185	235
--------------------------------	-----	-----

MACCHINA

Extra side reach, up to 40 cm more off set	✓	✓
Gear box position	external gearbox on end of hood	external gearbox on end of hood
Double skin in Hardox®	✓	✓
Rounded frame and chamfer on the outer end of hood	✓	✓
Double counter knife	✓	✓
Front safety flaps th. 6 mm	✓	✓
Professional rear roller Ø 194 mm with 4 roller bearings, mud scraper and interchangeable central body	✓	✓
Reflectors	✓	✓
Side Skids in Hardox®	•	•
Protection chains	•	•

TRANSMISSION

Wide angle cardan shaft	✓	✓
Tool holders - forestry type	✓	✓
Ventilator rotor	✓	✓
Double rotor support	-	✓
Tool screw in steel Ø 20 mm 12.9	✓	✓
Oscillating bearings with double column of balls	✓	✓
Free-wheel in gearbox	✓	✓
Automatic belt tensioner	✓	✓
Supplement for rotor with knife	•	•

SAFETY

Oleopneumatic anti-shock device	✓	✓
---------------------------------	---	---

HYDRAULIC SYSTEM

Hydraulic side movement with adjustable ram and double acting anti-creep valve	✓	✓
Hydraulic angling with safety tap for road transport	✓	✓

MAGNUM PLUS

OFF SET *FRONTAL* PROFESSIONAL SERIES

Self-cleaning roller position
unloading of mulched product behind the roller for faster working speed

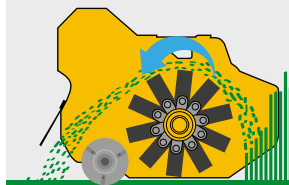

Rear roller position
unloading of mulched product in front of the roller for better shredding

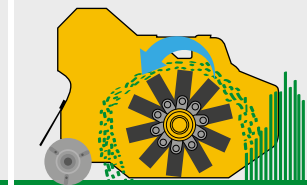

ROAD EDGES, DITCHES,
RIVER EDGES, PRUNINGS

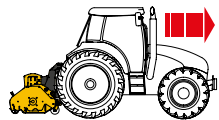

EXTRA REACH

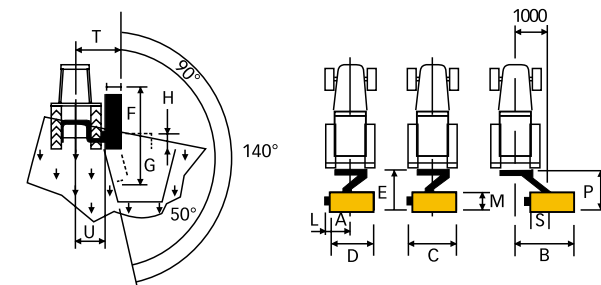

	A cm/in	B cm/in	C cm/in	D cm/in	E cm/in	F cm/in	G cm/in	H cm/in	L cm/in	M cm/in	P cm/in	T cm/in	U cm/in
4-20	107/ 42	402/ 158	218/ 86	200/ 79	196/ 77	240/ 94	160/ 63	55/22	18/7	104/ 41	196/ 77	270/ 106	215/ 85
4.5-25	107/ 42	482/ 190	268/ 106	250/ 98	196/ 77	290/ 114	195/ 77	55/22	18/7	104/ 41	196/ 77	270/ 106	215/ 85
5-30	107/ 42	502/ 198	318/ 125	300/ 118	196/ 77	340/ 134	233/ 92	55/22	18/7	104/ 41	196/ 77	270/ 106	215/ 85



DIRECTION OF ROTATION OF P.T.O.

PREDATOR

PROFESSIONAL SERIES



100 - 180 HP



STRENGTH POINTS



DOUBLE SKIN IN HARDOX®



3 YEARS WARRANTY
ON CAST IRON COMPONENT

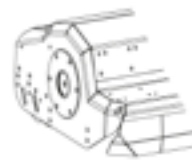

ROUNDED FRAME AND
CHAMFER ON THE OUTER END
OF HOOD



PROFESSIONAL REAR ROLLER
Ø 194 mm with 4 taper roller bearings,
mud scraper and central interchangeable
body, with 2 positions: 1) self-cleaning
2) rear



"VENTILATOR" ROTOR
electronically balanced. Forestry tool
holders moulded in boron steel.



DOUBLE ROTOR SUPPORT



DOUBLE COUNTER KNIFE
Increased rows of counter knives hold the
material in for more complete shredding



AUTOMATIC BELTS TENSIONER
The automatic tensioning system as well
as allowing constant power transmission
reduces belts wear.



EXTERNAL ROTOR SUPPORT
IN PRESSED STEEL
The external rotor support allows the easy
dismantling / replacement of the rotor and
/ or the bearings

PREDATOR		4-20	4.5-25	5-30
TECHNICAL SPECIFICATIONS				
Working width		200 cm / 79 in	250 cm / 98 in	300 cm / 118 in
Machine weight		2150 kg / 4740 lb	2350 kg / 5181 lb	2550 kg / 5622 lb
tools	knives max Ø 3,5 cm	48	60	96
	hammers max Ø 8 cm kg 2,1	16	20	32
rotor Ø	A	194 x 10 mm / 8 x 0,4 in	194 x 10 mm / 8 x 0,4 in	219 x 10 mm / 8,7 x 0,4 in
	B	454 mm / 18 in	454 mm / 18 in	480 mm / 19 in
N° belts Kevlar		1	1	1
CAT.		II-III	II-III	II-III
1000 RPM PTO	Rotor revolutions / peripheral tool speed	2050 rpm - 48,71 m/sec	2050 rpm - 48,71 m/sec	1800 rpm - 45,24 m/sec
HP max transmission		290 hp	290 hp	290 hp
Utilization		rear mounted		
TRACTOR REQUIREMENTS				
Minimum weight		2500 kg / 5512 lb	3000 kg / 6614 lb	4200 kg / 9259 lb
Minimum wheels setting		200 cm / 79 in	200 cm / 79 in	220 cm / 87 in

PREDATOR	4-20	4.5-25	5-30
MACHINE			
Extra side reach, up to 40 cm more off set	✓	✓	✓
Internal gearbox on top of hood	✓	✓	✓
Monocoque skin in Hardox® (th. 6 mm)	✓	✓	✓
Rounded frame and chamfer on the outer end of hood	✓	✓	✓
Double counter knife	✓	✓	✓
Front safety flaps th. 6 mm	✓	✓	✓
Stabilizer roller Ø 245 mm, hydraulic adjustable, with 4 taper roller bearings, mud scraper and central interchangeable body	✓	✓	✓
Professional rear roller Ø 194 mm with 4 taper roller bearings, mud scraper and central interchangeable body, with 2 positions: 1) self-cleaning 2) rear	✓	✓	✓
Throwing adjustment of the shredded material	✓	✓	✓
Reflectors	✓	✓	✓
Side Skids in Hardox®	•	•	•
Protection chains	•	•	•
TRANSMISSION			
Tool holders - forestry type	✓	✓	✓
Ventilator rotor	✓	✓	-
8-row rotor	-	-	✓
Tool screw in steel Ø 20 mm 12.9	✓	✓	✓
Oscillating bearings with double column of balls	✓	✓	✓
Rotor transmission with Kevlar toothed belt	✓	✓	✓
Rotor transmission with 150 HP Rexroth piston pump and cast iron gearbox	✓	✓	✓
Fix mounted frame RAPID LINK	•	•	•
Cardan hexalobe	•	•	•
HYDRAULIC SYSTEM			
Hydraulic side movement with double extension	✓	✓	✓
Hydraulic angling with safety tap for road transport	✓	✓	✓
Boom movements: by means of quick hydraulic couplings to the tractor (minimum flow required 40 lt / min; minimum 4 hydraulics couplings)	✓	✓	✓
FAST-TRONIC Electro-proportional with 4 compensated movements adjustable by the operator with graphic display	•	•	•
Kit 4.0 - Telemetry and remote diagnostics (only with Fast Tronic command)	•	•	•

PREDATOR

PROFESSIONAL SERIES

Self-cleaning roller position
unloading of mulched product behind the roller for faster working speed

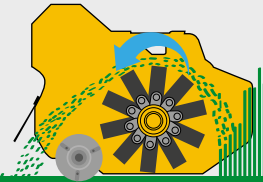

Rear roller position
unloading of mulched product in front of the roller for better shredding

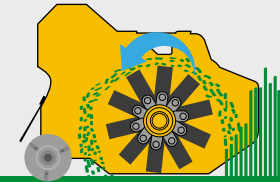

PERCHÉ SCEGLIERE ORSI?

ORSI offre una vasta gamma di prodotti, supporto tecnico, una struttura di concessionari localizzati in tutto il mondo, altamente specializzati e formati tramite training tecnici aziendali. Scegliere una macchina ORSI significa acquistare un prodotto di qualità Made In Italy e ricevere un'assistenza post-vendita qualificata. Quando avrai bisogno di ricambi, supporto o informazioni tecniche, ORSI sarà sempre al tuo fianco e ti supporterà per l'intera vita della tua macchina. Un professionista cerca sempre di munirsi di un nostro prodotto, perché scegliere il meglio significa scegliere ORSI.

- Oltre 40 anni di storia, fatta di esperienza nella trinciatura e premiata dal successo riconosciuto da utilizzatori e professionisti nel mondo.
- La possibilità di personalizzare le macchine al fine di soddisfare esigenze e peculiarità dettate dai diversi territori.
- Un team di professionisti al tuo servizio e supporto tecnico a disposizione dei nostri concessionari per risolvere rapidamente eventuali problematiche.
- Test personalizzati per ciascuna macchina prima di essere consegnata al cliente.
- Uno stock di ricambi originali sempre disponibili presso dealers, distributori o il nostro magazzino che possono essere recapitati con i migliori corrieri nazionali o internazionali.
- La possibilità di consultare tutti i prodotti online grazie al sito web sempre aggiornato con tutte le informazioni necessarie sia all'acquisto che al post-vendita.

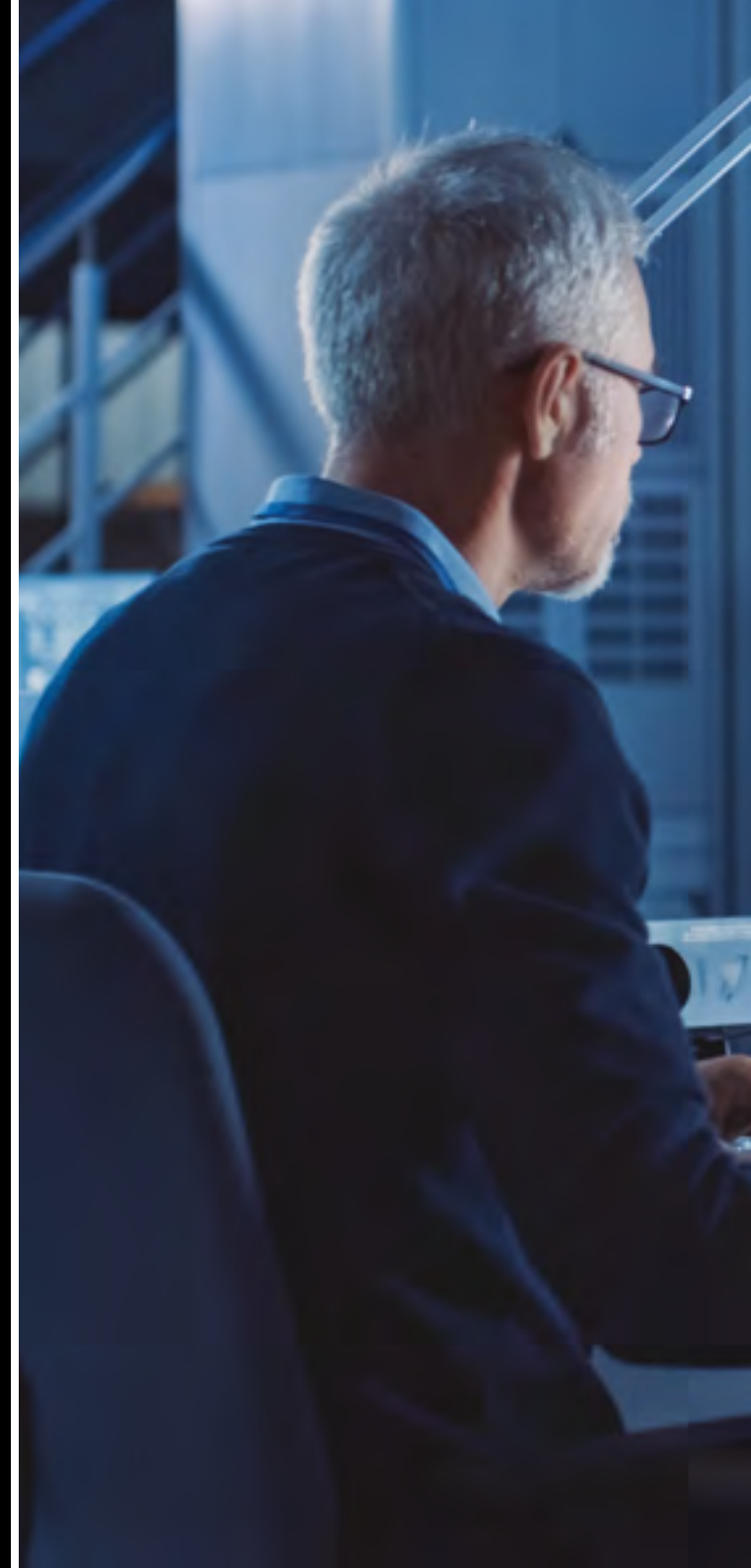

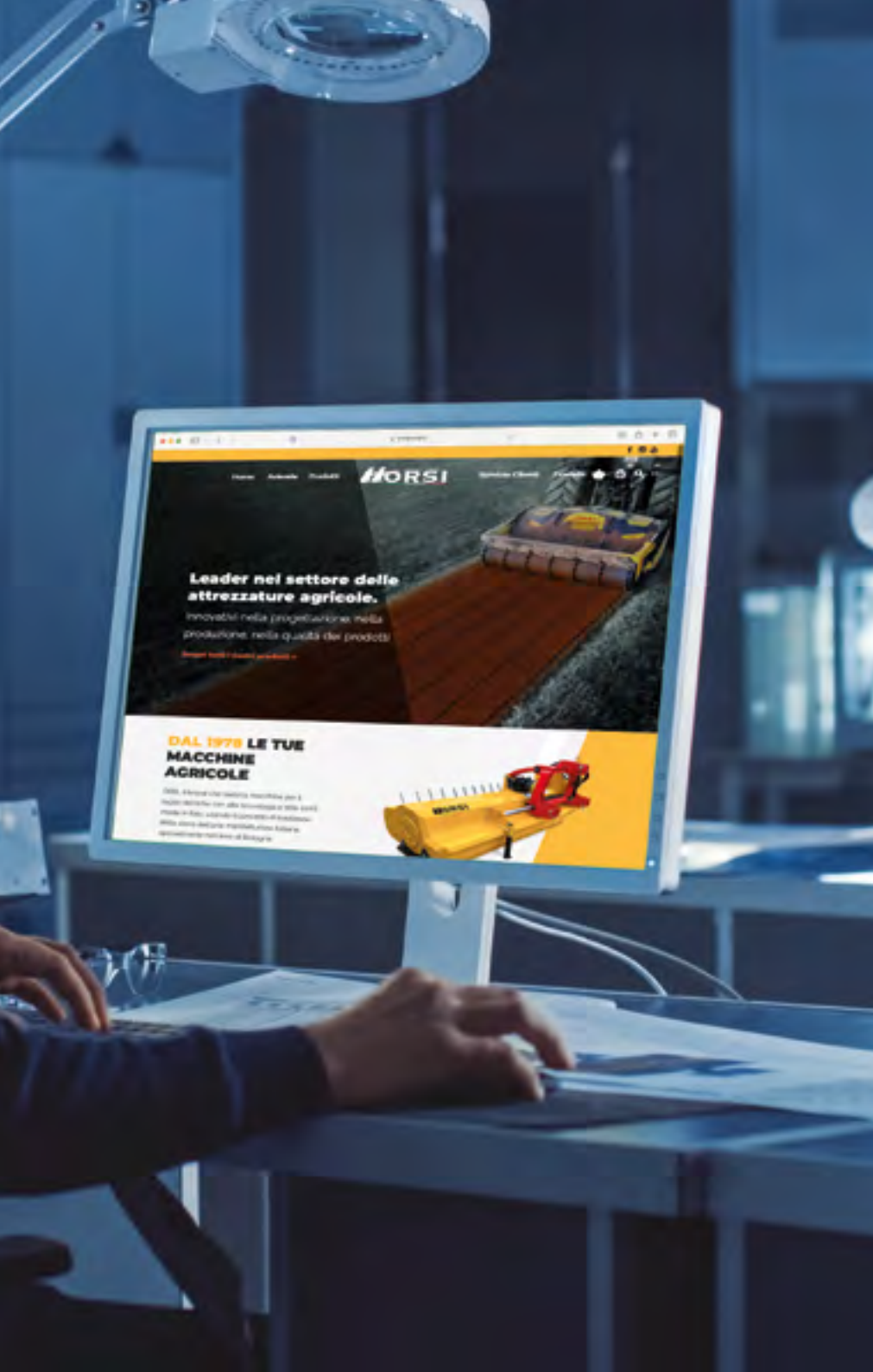

TRINCIA FORESTALI

Una vasta gamma di trinciatrici forestali adatte a molti usi come tritare legna di grosse dimensioni, ramaglie, arbusti, e particolarmente adatta anche per uso agricolo ad esempio per le potature nei frutteti. Una vasta gamma per trattori da 70 fino a 500 hp, con differenti tipi di rotore, a denti fissi o a scomparsa per poter esaudire differenti necessità di lavorazione.



TRINCE FISSE

Orsi con una differente varietà di trinciatrici adatte ai più svariati tipi di lavoro, dalla gamma dedicata al giardinaggio fino alle macchine professionali destinate al lavoro dopo le potature.

Una gamma per trattori da 20 fino a 170 hp, con differenti tipi di rotore ed accessori, per poter esaudire differenti necessità di lavorazione.

PER INFORMAZIONI SUI MODELLI ORSI VISITA IL NOSTRO SITO WWW.ORSIGROUP.IT

DECESPUGLIATORI

ORSI leader mondiale riconosciuto per la sua grande esperienza in questo settore offre una vasta gamma necessaria per differenti tipologie di lavoro, una gamma dedita specialmente per l'agricoltura e una gamma per i contoterzisti e lavori stradali che necessitano di macchine con delle alte prestazioni orarie.



ELEVATORI

Orsi dal 2002 produce i propri elevatori idraulici per il carico e il trasporto della raccolta di tutti i tipi di frutta, macchine con alzate verticali in versione duplex o triplex e con differenti portate di carico a seconda della richiesta, modelli per tutti i tipi di trattori dal piccolo alle grandi potenze.



« The first Orsi Mulcher was purchased by my family about 25 years ago. The main quality we were looking for was reliability and performance of the machines in very difficult field conditions. The ORSI machines we have had are as reliable as possible, and have always done the work in the fields very well and importantly, we are extremely happy with the service. »

Azienda Agricola Boselli
Daniele e Filippo (BOLOGNA) Italia



ORSI GROUP S.R.L.

Via S. Andrea, 2A
Mascarino di Castello d'Argile
40050 / BOLOGNA / ITALY

Ph. +39 051 6867072

Fax +39 051 6867104

info@orsigroup.it

www.orsigroup.it