

# DECESPUGLIATORI

Serie DEC P

DEC 500 P C



## Catalogo parti di ricambio

*Spare parts catalogue*

*Catalogue des pièces détachées*

*Ersatzteilkatalog*

*Cátalogo piezas de recambio*

Rev. 0 Ed. 21/02/2022

## Tifermec Oleodinamica S.r.l.

Via C. Marx, 2/A- 06012 Cerbara di Città di Castello – PG

Tel. +39.075.8510376 | Fax. +39.075.8510318

tifermec@tifermec.com

www.tifermec.com



## **CONDIZIONI DI GARANZIA**

La nostra azienda si riserva il diritto di apportare, in qualsiasi momento, eventuali modifiche per motivi di carattere tecnico o commerciale, pertanto le descrizioni e le illustrazioni contenute in questa pubblicazione sono aggiornate fino al momento della stampa.

Le illustrazioni delle parti potrebbero essere diverse dai particolari montati sulla macchina, quindi solo il numero di codice rilevabile sul catalogo parti di ricambio determina la validità del pezzo.

## **CONDITIONS OF GUARANTEE**

The manufacturer reserves the right to modify the machines for commercial or technical motives, in every moment, therefore descriptions and illustrations of this publication are up to date until printing.

If illustrations of tools or parts of the machine are different from this book, please refer to code number written in the spare parts catalogue.

## **CONDITIONS DE GARANTIE**

Notre entreprise se réserve le droit d'apporter, à tout moment, des modifications éventuelles pour des raisons à caractère technique ou commercial, c'est pourquoi les descriptions et les illustrations contenues dans cette brochure sont mises à jour jusqu'au moment de l'impression.

Les illustrations des diverses parties pourraient différer des pièces montées sur la machine, seul le numéro de code, qu'on peut voir sur le catalogue des pièces de rechange, indique quelle est la bonne pièce.

## **GARANTIEBEDINGUNGEN**

Unsere Firma behält sich das Recht vor jederzeit evtl. Änderungen aus technischen oder kommerziellen Gründen vorzunehmen, deshalb entsprechen die in dieser Ausgabe vorhandenen Beschreibungen und Abbildungen dem aktuellsten Stand der Technik.

Es besteht die Möglichkeit, dass die abgebildeten Teile mit den auf der Maschine eingebauten Teilen nicht übereinstimmen, deshalb ist zur Bestimmung des Teiles nur die im Ersatzteilkatalog aufgeführte Artikelnummer maßgebend.

## **CONDICIONES DE GARANTÍA**

Nuestra empresa se reserva el derecho de modificar las máquinas, en cualquier momento, por motivos técnicos o comerciales, por lo tanto las descripciones e ilustraciones que contiene este manual están confirmadas hasta el momento de la publicación.

La ilustración de las piezas podría ser distinta de las piezas montadas en la máquina, por lo tanto sólo el número de código que se encuentra en el catálogo piezas de repuesto determina la validez de la pieza.

## MODALITÀ DI ORDINAZIONE

Per facilitare la ricerca a magazzino e la spedizione dei pezzi di ricambio si pregano vivamente i Sigg.ri Clienti di attenersi alle seguenti norme specificando sempre:

- Modello, numero di matricola e anno di costruzione della macchina.
- Numero di edizione del presente catalogo ricambi.
- Quantità dei pezzi desiderati.
- Numero di codice e denominazione di detti pezzi.
- Indirizzo esatto e ragione sociale del Committente; inoltre eventuale diversa destinazione per la consegna della merce.

## HOW TO ORDER

In order to facilitate the research of spare parts in our warehouse and their consequent shipment, the customers are kindly requested to follow the ordering standards indicated below and specify at all times:

- Machine model, serial number and year of construction.
- Version number of the spare parts catalogue.
- Quantity of parts required.
- Code number and description of the parts required.
- Exact address and company name of the purchaser and delivery address if not the same of the purchaser.

## MODALITES DE COMMANDE

Afin de faciliter les recherches en atelier ainsi que l'expédition des pièces de rechange, les clients sont priés de bien vouloir suivre les instructions suivantes, et de spécifier toujours:

- Modèle, le numéro de matricule et l'année de construction de la machine.
- Numéro d'édition de ce catalogue pièces de rechange.
- Quantité de pièces désirées.
- Numéro de code et la désignation des pièces concernées.
- Adresse exacte et la raison sociale du commettant; ainsi que l'éventuelle adresse de livraison si différente.

## BESTELLUNG

Um die Suche im Lager und den Verstand der Ersatzteile zu erleichtern, bitten wir unsere Kunden, stets die folgenden Angaben zu übermitteln:

- Modell, Seriennummer und Baujahr der Maschine.
- Ausgabennummer des vorliegenden Ersatzteilkatalogs.
- Menge gewünschter Teile.
- Kode-Nr. und Benennung der genannten Teile.
- Genaue Anschrift und Firmenname des Auftraggebers; des weitern die eventuell abweichende Anschrift für die Auslieferung der Ware.

## EFECTUACION DEL PEDIDO

Para facilitar la búsqueda en el depósito y el despacho de las piezas de repuesto se ruega a los Sres. Clientes que se atengan a las siguientes instrucciones e indiquen siempre los siguientes datos:

- Modelo, número de serie y año de fabricación de la máquina.
- Número de edición del presente catálogo de repuestos.
- Cantidad de piezas deseadas.
- Número de código y descripción de las piezas.
- Dirección exacta y razón social del Cliente, además la dirección de entrega de la mercancía en caso que la misma difiera de la anterior.

Pos.	Qty	Codice	Disegno	Descrizione	Description	Descripción	Beschreibung	Designation
1	1	GSC200B219	650.21.00	SERBATOIO	TANK	RESERVOIR	TANK	DEPÓSITO
2	4	GCB000B004	M8	DADO	NUT	ECROU	MUTTER	TUERCA
3	10	GCB000D006	8	ROSETTA	WASHER	RONDELLE	SCHEIBE	ROSETA
4	4	GCB000A006	M8x25	VITE	SCREW	VIS	SCHRAUBE	TORNILLO
5	1	GSC200B225	650.21.13	CARTER	CARTER	CARTER	GEHAEUSE	CARTER
6	1	GSC200B123	501.14.00	TELAIO	FRAME	CHASSIS	RAHMEN	CHASIS
7	1	GSC200B176	530.21.14	CARTER	CARTER	CARTER	GEHAEUSE	CARTER
8	1	GCC000G001	420.51.00	PROTEZIONE	PROTECTION	PROTECTEUR	SCHUTZ-EINHEIT	PROTECCIÓN
9	4	GCB000A004	10x25	VITE	SCREW	VIS	SCHRAUBE	TORNILLO
10	4	GCB000D005	10	ROSETTA GROWER	WASHER	RONDELLE	SCHEIBE	ROSETA
11	4	GCB000D004	10	RONDELLA	WASHER	RONDELLE	SCHEIBE	ARANDELA
12	1	GSC200B226	650.21.18	CARTER	CARTER	CARTER	GEHAEUSE	CARTER
13	1	GST100D003	60.20.16	PERNO	PIN	AXE	ACHSE	PERNO
14	3*	GCB000E001	10	COPIGLIA	SPLIT PIN	GOUPILLE	STIFT	PASADOR
15	2	GST100C047	650.20.03	PERNO	PIN	AXE	ACHSE	PERNO
16	2	GCB000F006	ø14X70	SPINA	PIN	GOUPILLE	STECKDOSE	CLAVIJA
17	4	GST000A019		RONDELLA	WASHER	RONDELLE	SCHEIBE	ARANDELA
18	2	GCB000B032	39MB BASSO	DADO	NUT	ECROU	MUTTER	TUERCA
19	1	GSC200B121	501.05.00	GIREVOLE	SWIVEL	PIVOTANT	SCHWENKEN	GIRAR
20	2	GSC100B051	420.06.00	PIEDE	FOOT	PIED	FUSS	PIE
21	2	GST100C009	370.20.01	PERNO	PIN	AXE	ACHSE	PERNO
22	2	GST100C043	60.20.15	PERNO	PIN	AXE	ACHSE	PERNO
23	1	GOC000A091	3/4 GAS	TAPPO	PLUG	CLAPET	STOEPSSEL	TAPÓN
24	1	GSC200B272	510.17.00	SUPPORTO	BRACKET	SUPPORT	SUPPORT	SOPORTE
25	1	GOD000D040	420.25.00	MARTINETTO	CYLINDER	CYLINDER	ZYLINDER	GATO
25A	1	RMG000A012		GUARNIZIONI	SEALS	SCELLÉS	DICHTUNGEN	FOCAS
26	2	GCB000A028	M10x80	VITE	SCREW	VIS	SCHRAUBE	TORNILLO
27	1	GST100C046	650.20.02	PERNO	PIN	AXE	ACHSE	PERNO
28	2	GCB000F004	12x60	SPINA	PIN	GOUPILLE	STECKDOSE	CLAVIJA
29	1	GST100C055	70.20.09	PERNO	PIN	AXE	ACHSE	PERNO
30	2	GST000B006	50x40x150	BOCCOLA	BUSH	BAGUE	HUELSE	CASQUILLO
31	3	GCB000D003	12	ROSETTA	WASHER	RONDELLE	SCHEIBE	ROSETA
32	2	GCB000A017		VITE	SCREW	VIS	SCHRAUBE	TORNILLO
33	2	GCB000A013	M12X40	VITE	SCREW	VIS	SCHRAUBE	TORNILLO
34	2	GCB000B001	12	DADO	NUT	ECROU	MUTTER	TUERCA
35	1	GCB000A016	10x40	VITE	SCREW	VIS	SCHRAUBE	TORNILLO
36	8	GCB000A019	8x20	VITE	SCREW	VIS	SCHRAUBE	TORNILLO
37	1	GSC200B092	430.21.19	PIASTRA	PLATE	PLAQUE	PLATTE	PLACA
38	3	GSC200B267	650.21.19	PIASTRA	PLATE	PLAQUE	PLATTE	PLACA
39	3	GCB000D004	10	RONDELLA	WASHER	RONDELLE	SCHEIBE	ARANDELA

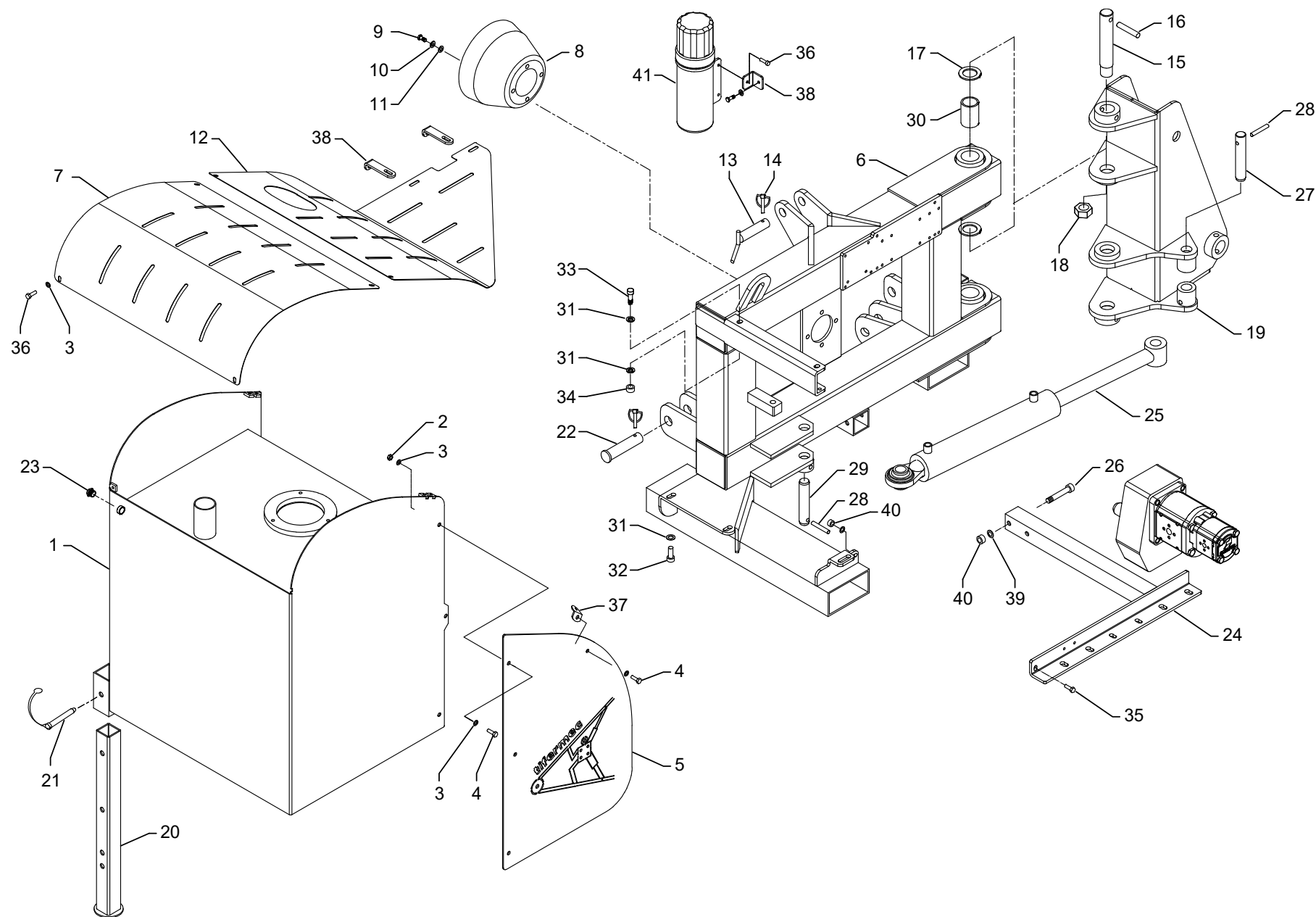

Pos.	Qty	Codice	Disegno	Descrizione	Description	Descripción	Beschreibung	Designation
40	3	GCB000B002	10	DADO	NUT	ECROU	MUTTER	TUERCA
41	1	GCC000G002		CONTENITORE	BOX	BOX	BOX	BOX

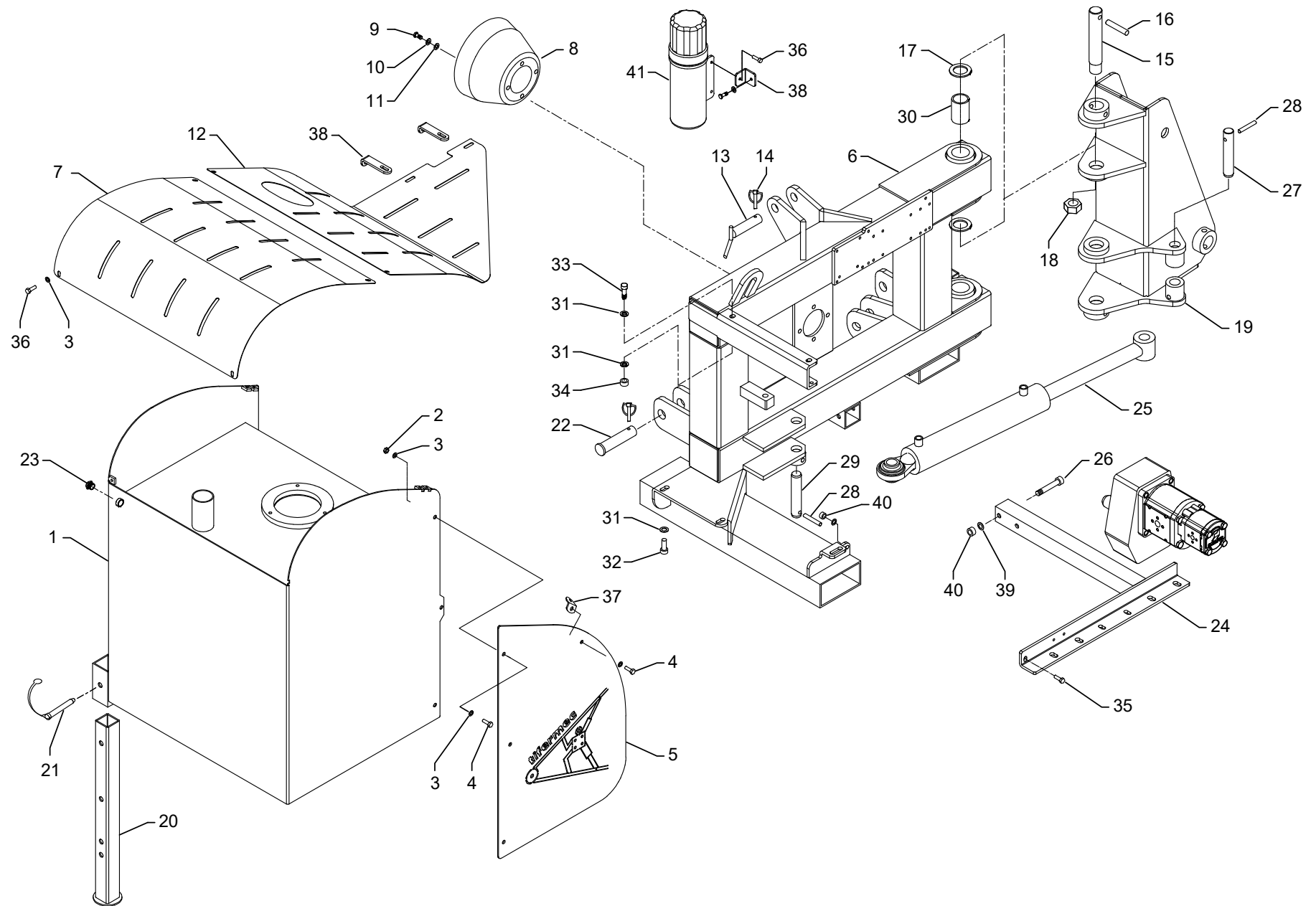

Pos.	Qty	Codice	Disegno	Descrizione	Description	Descripción	Beschreibung	Designation
1	1	GSC200B121	501.05.00	GIREVOLE	SWIVEL	PIVOTANT	SCHWENKEN	GIRAR
2	1	GOD000D041	650.18.00	MARTINETTO	CYLINDER	CYLINDER	ZYLINDER	GATO
2A		RMG000A033	650.18.00kit	KIT GUARNIZIONI	#N/D	#N/D	#N/D	#N/D
3	1	GST100C047	650.20.03	PERNO	PIN	AXE	ACHSE	PERNO
4	2	GCB000F006	ø14X70	SPINA	PIN	GOUPILLE	STECKDOSE	CLAVIJA
5	1	GST100C033	60.20.03	PERNO	PIN	AXE	ACHSE	PERNO
6	1	GST100C041	60.20.11	PERNO	PIN	AXE	ACHSE	PERNO
7	2	GST000B006	50x40x150	BOCCOLA	BUSH	BAGUE	HUELSE	CASQUILLO
8	3	GCB000F004	12x60	SPINA	PIN	GOUPILLE	STECKDOSE	CLAVIJA
9	1	GST100C045	650.20.01	PERNO	PIN	AXE	ACHSE	PERNO
10	6	GCB000F003	10x50	SPINA	PIN	GOUPILLE	STECKDOSE	CLAVIJA
11	1	GST000B009	35x25x123	BOCCOLA	BUSH	BAGUE	HUELSE	CASQUILLO
12	1	GST000B004	40x30x123	BOCCOLA	BUSH	BAGUE	HUELSE	CASQUILLO
13	1	GSC200B120	501.04.00	BRACCIO	ARM	BRAS	ARM	BRAZO
14	1	GOD000D042	501.12.00	MARTINETTO	CYLINDER	CYLINDER	ZYLINDER	GATO
14A	1	RMG000A032		GUARNIZIONI	SEALS	SCÉLLÉS	DICHTUNGEN	FOCAS
15	1	GST100C051	70.20.05	PERNO	PIN	AXE	ACHSE	PERNO
16	1	GSC200B132	501.16.01	PROTEZIONE	PROTECTION	PROTECTEUR	SCHUTZ-EINHEIT	PROTECCIÓN
17	1	GSC200B119	501.01.00	BRACCIO	ARM	BRAS	ARM	BRAZO
18	2	GCB000B032	39MB BASSO	DADO	NUT	ECROU	MUTTER	TUERCA
19	1	GST100C041	60.20.11	PERNO	PIN	AXE	ACHSE	PERNO
20	1	GST100C029	500.20.01	PERNO	PIN	AXE	ACHSE	PERNO
21	1	GST100C030	500.20.02	PERNO	PIN	AXE	ACHSE	PERNO
23	1	GSC200B134	501.16.02	CARTER	CARTER	CARTER	GEHAEUSE	CARTER
24	2	GCB000D012	23	ROSETTA	WASHER	RONDELLE	SCHEIBE	ROSETA
25	6	GCB000A001	M14x40	VITE	SCREW	VIS	SCHRAUBE	TORNILLO
26	1	GST100C058	70.20.12	PERNO	PIN	AXE	ACHSE	PERNO
28	2*	GSC200B105	500.10.00	MANOVELLA	LEVER	MANIVELLE	KURBEL	PALANCA
30	1	GSC200B112		SUPPORTO	BRACKET	SUPPORT	SUPPORT	SOPORTE
31	1	GSC200B104	500.09.00	BIELLA	CRANK	BIELLE	KURBELSTANGE	BIELA
32	1	TC	-	TESTATA COMPLETA	COMPLETE HEAD	TÊTE COMPLÈTE	KOMPLETTER KOPF	CABEZA COMPLETA
33	1	GOD000D043	501.13.00	MARTINETTO	CYLINDER	CYLINDER	ZYLINDER	GATO
33A	1	RMG000A007	501.13.00kit	KIT GUARNIZIONI	#N/D	#N/D	#N/D	#N/D
34	6	GCB000B015	M16	DADO	NUT	ECROU	MUTTER	TUERCA
35	6	GCB000D016	16	ROSETTA	WASHER	RONDELLE	SCHEIBE	ROSETA
36	1	GST100C041	60.20.11	PERNO	PIN	AXE	ACHSE	PERNO
37	4	GCB000D006	8	ROSETTA	WASHER	RONDELLE	SCHEIBE	ROSETA
38	4	GCB000A019	8x20	VITE	SCREW	VIS	SCHRAUBE	TORNILLO
39	4	GCB000N002	8 MA DIRITTO	INGRASSATORE	FATTENER	ENGRAISSEUR	MASTER	FATTENER
40	1	GCB000B022	M 27 MB	DADO	NUT	ECROU	MUTTER	TUERCA



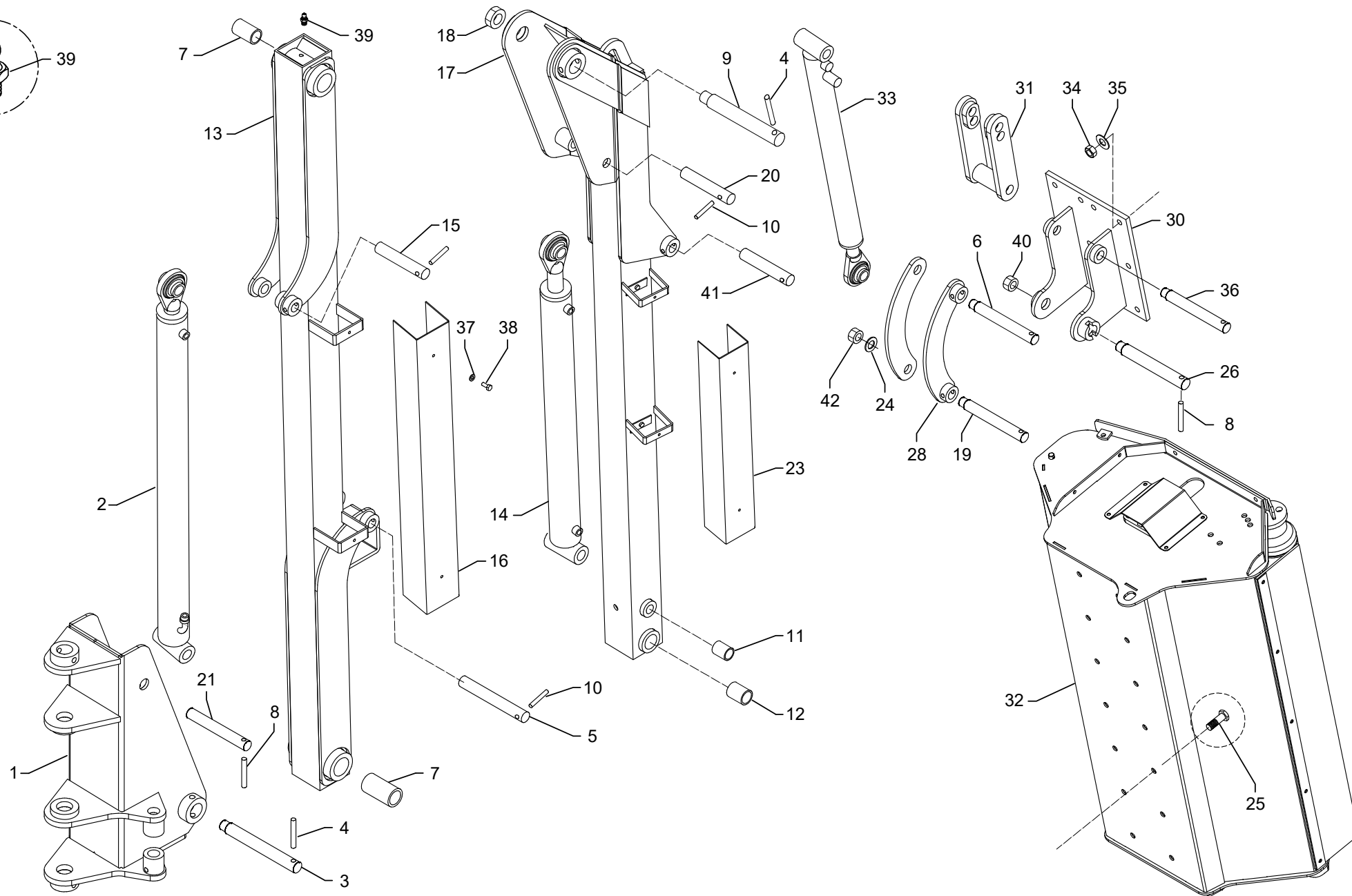
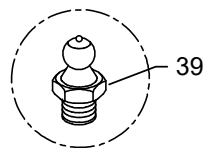

Pos.	Qty	Codice	Disegno	Descrizione	Description	Descripción	Beschreibung	Designation
41	1	GST100C033	60.20.03	PERNO	PIN	AXE	ACHSE	PERNO
42	1	GCB000B021	24 MB ALTO	DADO	NUT	ECROU	MUTTER	TUERCA

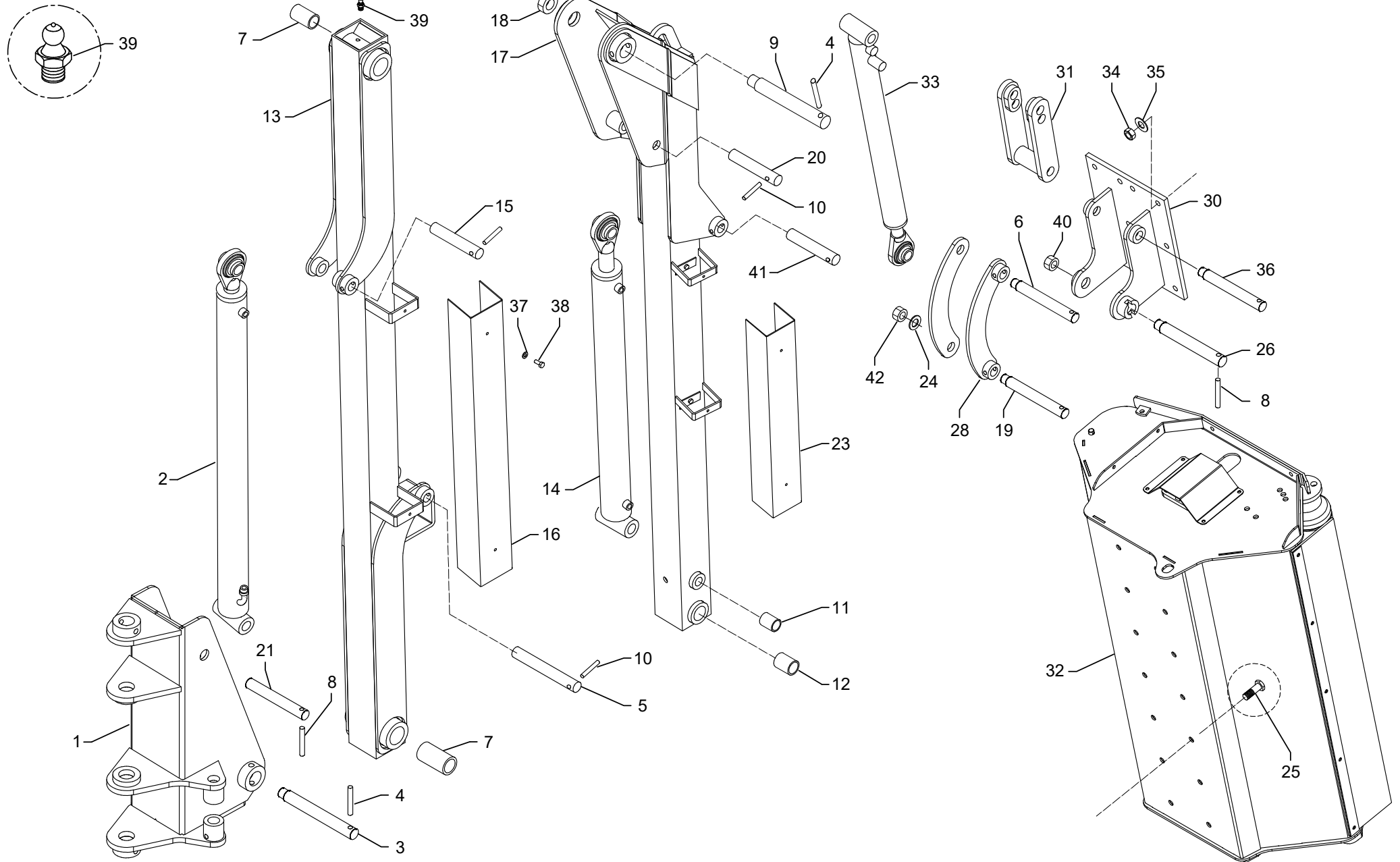

Pos.	Qty	Codice	Disegno	Descrizione	Description	Descripción	Beschreibung	Designation
1	1	GOC000A173		TAPPO	PLUG	CLAPET	STOEPSSEL	TAPÓN
2	3	GCB000A078	M10x25	VITE	SCREW	VIS	SCHRAUBE	TORNILLO
4	1	GOC000A090		INDICATORE	INDICATOR	INDICATEUR	ANZEIGE	INDICADOR
5	1	GOS000C003		FILTRO	FILTER	FILTRE	FILTER	RESPIRADERO
6	1	GOS000C007		COPERCHIO	COVER	COUVERCLE	DECKEL	TAPA
7	1	GOC000M004	1"	RONDELLA	WASHER	RONDELLE	SCHEIBE	ARANDELA
8	1	GOC000A011	3/8 MM	ADATTATORE	ADAPTER	ADAPTATEUR	ADAPTER	ADAPTADOR
9	1	GOS000D015		MOLTIPLICATORE	MULTIPLIER	MULTIPLICATEUR	MULTIPLIKATOR	MULTIPLICADOR
10	1	GOS000B030		POMPA	PUMP	POMPE	PUMPE	BOMBA
11	4	GCB000A116	10x30	VITE	SCREW	VIS	SCHRAUBE	TORNILLO
13	1	GOC000M001	44228	RONDELLA	WASHER	RONDELLE	SCHEIBE	ARANDELA
14	1	GOC000A003	1/2" 1/2"	RACCORDO	CONNECTOR	RACCORD	VERBINDEINHEIT	UNIÓN
15	1	GLD000B371	1/2R1L1200FDF90	TUBAZIONE	PIPE	TUBE	FEDERHALTER	TUBO
16	1	GLD000B365	1"R1L700FDF90	TUBAZIONE	PIPE	TUBE	FEDERHALTER	TUBO
17	1	GOC000A018	3/4 MM	ADATTATORE	ADAPTER	ADAPTATEUR	ADAPTER	ADAPTADOR
18	1	GOC000M002	44228	RONDELLA	WASHER	RONDELLE	SCHEIBE	ARANDELA
20	1	GOC000M006	44411	RONDELLA	WASHER	RONDELLE	SCHEIBE	ARANDELA
21	1	GOC000A019	3/8 MM	ADATTATORE	ADAPTER	ADAPTATEUR	ADAPTER	ADAPTADOR
24	1	GOS000D004		MOZZO	HUB	MOYEU	NABE	CUBO
25	2	GOC000A010	44411	RACCORDO	CONNECTOR	RACCORD	VERBINDEINHEIT	UNIÓN
26	1	GOC000M002	44228	RONDELLA	WASHER	RONDELLE	SCHEIBE	ARANDELA
27		GOC000A017	1/4"	ADATTATORE	ADAPTER	ADAPTATEUR	ADAPTER	ADAPTADOR
28	1	GLD000B905	1"1/4R4L470FDF90	TUBAZIONE	PIPE	TUBE	FEDERHALTER	TUBO
29	1	GOC000A021	1" 1/4	ADATTATORE	ADAPTER	ADAPTATEUR	ADAPTER	ADAPTADOR
30	1	GOC000A171		RUBINETTO	TAP	ROBINET	HAHN	GRIFO
35	3	GCB000A078	M10x25	VITE	SCREW	VIS	SCHRAUBE	TORNILLO
36	3	GCB000D004	10	RONDELLA	WASHER	RONDELLE	SCHEIBE	ARANDELA
37	3	GCB000D005	10	ROSETTA GROWER	WASHER	RONDELLE	SCHEIBE	ROSETA
39	2	GOC000M005	1 1/4"	RONDELLA	WASHER	RONDELLE	SCHEIBE	ARANDELA
40	1	GOC000A021	1" 1/4	ADATTATORE	ADAPTER	ADAPTATEUR	ADAPTER	ADAPTADOR
41	3	GCB000A086	6x18	VITE	SCREW	VIS	SCHRAUBE	TORNILLO
42	2	GOC000A001	GR2	RACCORDO	CONNECTOR	RACCORD	VERBINDEINHEIT	UNIÓN
43	2	GOC000M001	44228	RONDELLA	WASHER	RONDELLE	SCHEIBE	ARANDELA
44	1	GOC000A073	3/8 MM	ADATTATORE	ADAPTER	ADAPTATEUR	ADAPTER	ADAPTADOR
45	1	GLD000B321	3/8R2L500F90F90	TUBAZIONE	PIPE	TUBE	FEDERHALTER	TUBO
46	1	GLD000B369	1"R2L600FDF90	TUBAZIONE	PIPE	TUBE	FEDERHALTER	TUBO
49	1	GOC000A187	1"	RACCORDO	CONNECTOR	RACCORD	VERBINDEINHEIT	UNIÓN
50	1	GOC000M002	44228	RONDELLA	WASHER	RONDELLE	SCHEIBE	ARANDELA
51	1	GOC000A083	3/4"	TAPPO	PLUG	CLAPET	STOEPSSEL	TAPÓN
52	1	GOC000A064	1"	RACCORDO	CONNECTOR	RACCORD	VERBINDEINHEIT	UNIÓN

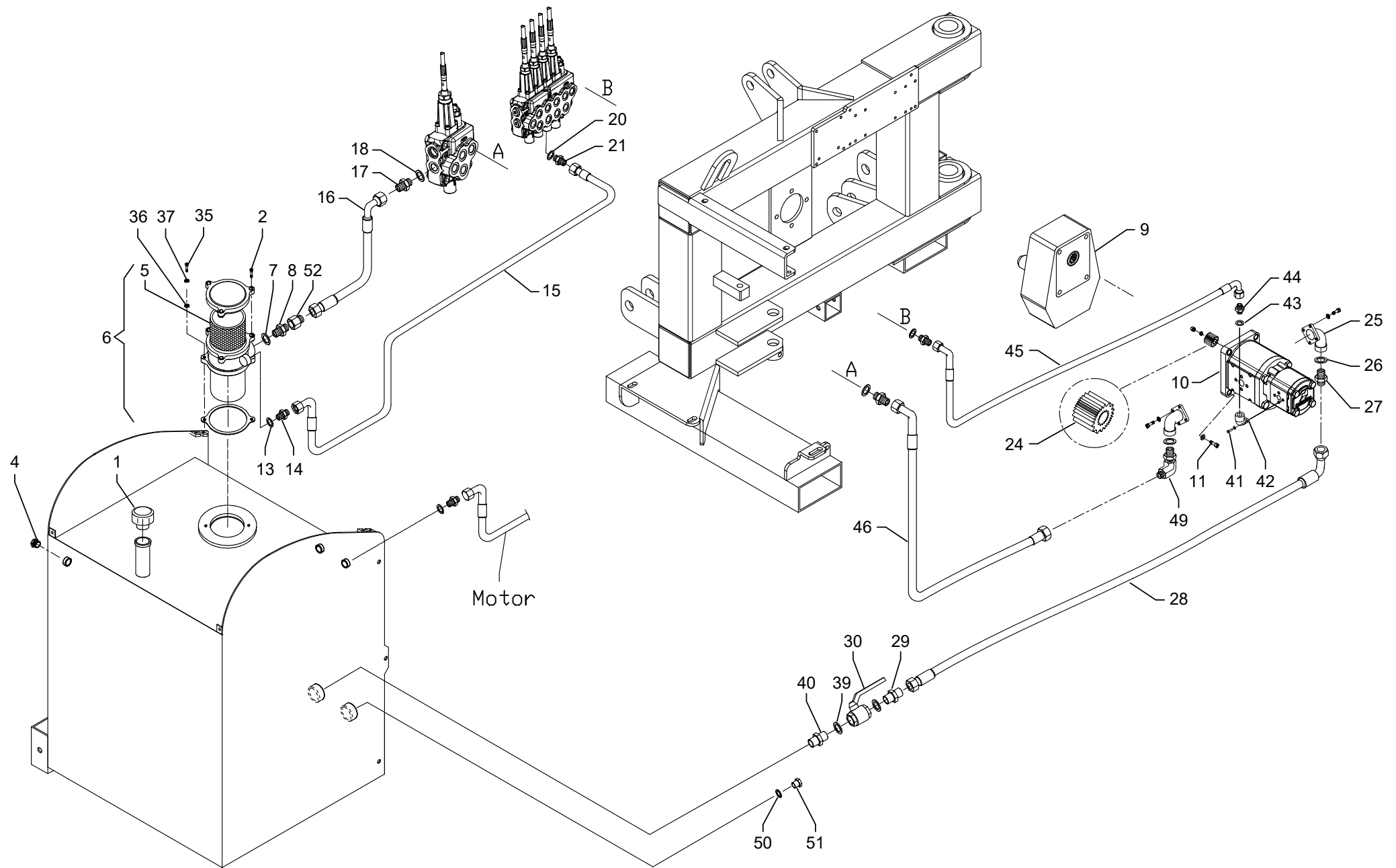

Pos.	Qty	Codice	Disegno	Descrizione	Description	Descripción	Beschreibung	Designation
1	1	GOS000F001	650.47.00	ACCUMULATORE	ACCUMULATOR	ACCUMULATEUR	AKKUMULATOR	ACUMULADOR
2	1	GOC000A078	3/8" - 18x1,5	RACCORDO	CONNECTOR	RACCORD	VERBINDEINHEIT	UNIÓN
3	1	GOC000A139	1/4" 1/4" M OC	RACCORDO	CONNECTOR	RACCORD	VERBINDEINHEIT	UNIÓN
4	1	GLD000B352	1/4"R2L350FDF90	TUBAZIONE	PIPE	TUBE	FEDERHALTER	TUBO
5	1	GOC000A055	1/4 MMF	RACCORDO	CONNECTOR	RACCORD	VERBINDEINHEIT	UNIÓN
6	1	GLD000B342	1/4"R2L700FDF90	TUBAZIONE	PIPE	TUBE	FEDERHALTER	TUBO
7	1	GOC000A050	1/4"1/4" MM	RACCORDO	CONNECTOR	RACCORD	VERBINDEINHEIT	UNIÓN
8	1	GLD000B343	1/4R2L800FDF90	TUBAZIONE	PIPE	TUBE	FEDERHALTER	TUBO
9	1	GOC000A058	1/4" MF	PROLUNGA	EXTENSION	RALLONGE	VERLAENGERUNG	PROLONGACIÓN
10	1	GOC000A074	3/8 MM	ADATTATORE	ADAPTER	ADAPTATEUR	ADAPTER	ADAPTADOR
11	9	GOC000M006	44411	RONDELLA	WASHER	RONDELLE	SCHEIBE	ARANDELA
12	1	GLD000B357	1/4"R2L2250FDF90	TUBAZIONE	PIPE	TUBE	FEDERHALTER	TUBO
13	1	GLD000B357	1/4"R2L2250FDF90	TUBAZIONE	PIPE	TUBE	FEDERHALTER	TUBO
14	5	GOC000M003	1/4"	RONDELLA	WASHER	RONDELLE	SCHEIBE	ARANDELA
15	1	GOC000A198	90 1/4" MG-FG	TUBAZIONE	PIPE	TUBE	FEDERHALTER	TUBO
16	1	GOC000A074	3/8 MM	ADATTATORE	ADAPTER	ADAPTATEUR	ADAPTER	ADAPTADOR
17	1	GOD000D040	420.25.00	MARTINETTO	CYLINDER	CYLINDER	ZYLINDER	GATO
18	1	GOD000D041	650.18.00	MARTINETTO	CYLINDER	CYLINDER	ZYLINDER	GATO
19	1	GOD000D042	501.12.00	MARTINETTO	CYLINDER	CYLINDER	ZYLINDER	GATO
20	1	GLD000B356	1/4R2L2000FDFD	TUBAZIONE	PIPE	TUBE	FEDERHALTER	TUBO
21	1	GLD000B356	1/4R2L2000FDFD	TUBAZIONE	PIPE	TUBE	FEDERHALTER	TUBO
22	1	GOC000A093	44287	VITE	SCREW	VIS	SCHRAUBE	TORNILLO
23	1	GOS000A133	1/4"	RACCORDO	CONNECTOR	RACCORD	VERBINDEINHEIT	UNIÓN
24	3	GOC000A017	1/4"	ADATTATORE	ADAPTER	ADAPTATEUR	ADAPTER	ADAPTADOR
25	1	GOC000A074	3/8 MM	ADATTATORE	ADAPTER	ADAPTATEUR	ADAPTER	ADAPTADOR
26	1	GOC000A017	1/4"	ADATTATORE	ADAPTER	ADAPTATEUR	ADAPTER	ADAPTADOR

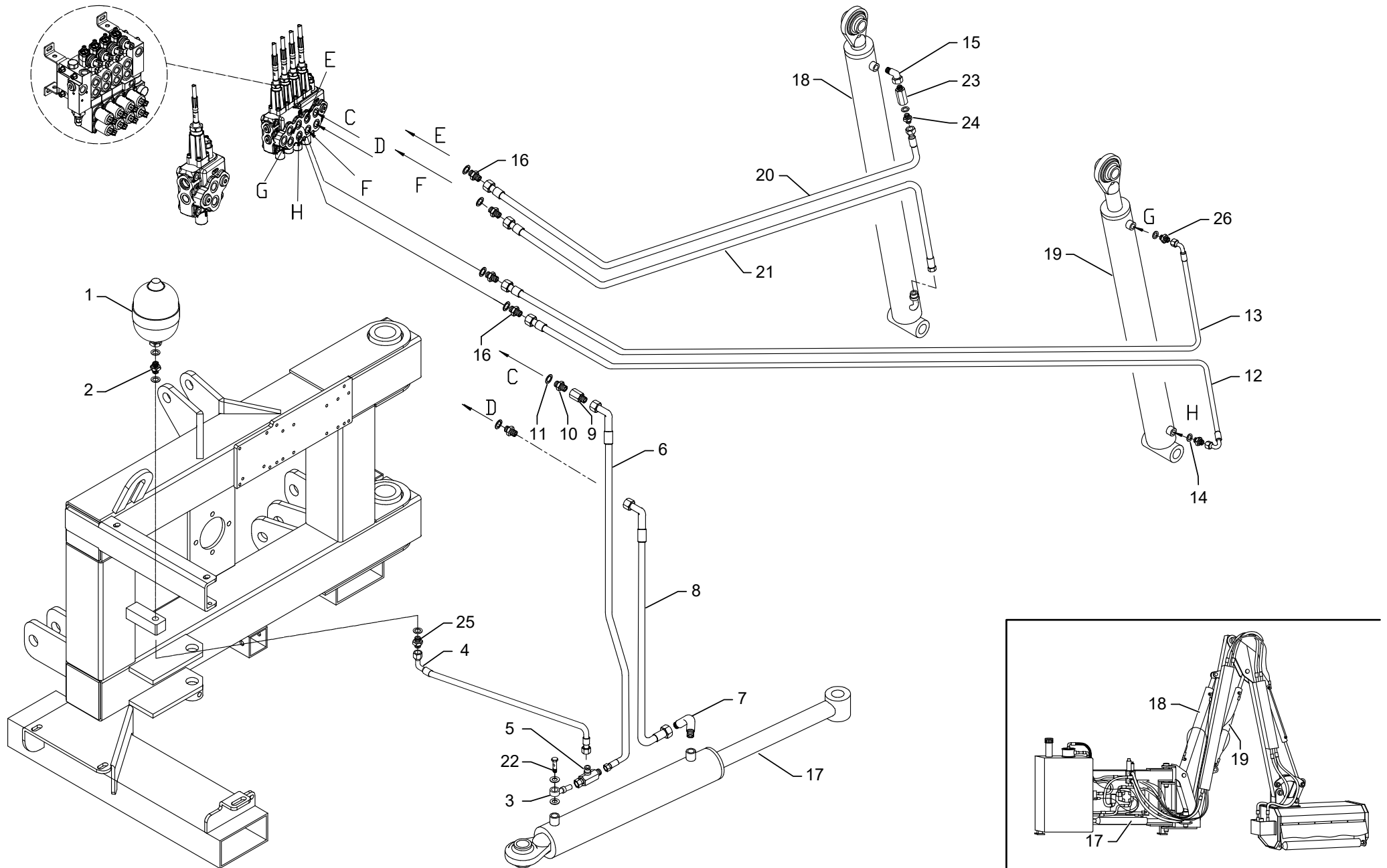

Pos.	Qty	Codice	Disegno	Descrizione	Description	Descripción	Beschreibung	Designation
1	2	GOC000M002	44228	RONDELLA	WASHER	RONDELLE	SCHEIBE	ARANDELA
2	2	GOC000A011	3/8 MM	ADATTATORE	ADAPTER	ADAPTATEUR	ADAPTER	ADAPTADOR
3	1	GLD000B368	1"R2L1400FDFD	TUBAZIONE	PIPE	TUBE	FEDERHALTER	TUBO
4	1	GLD000B368	1"R2L1400FDFD	TUBAZIONE	PIPE	TUBE	FEDERHALTER	TUBO
5	1	GLD000C006	501.30.52	TUBAZIONE	PIPE	TUBE	FEDERHALTER	TUBO
6	2	GLD000B366	1"R2L850FDFD	TUBAZIONE	PIPE	TUBE	FEDERHALTER	TUBO
7	1	GLD000B375	1/4"R2L3900FDF90	TUBAZIONE	PIPE	TUBE	FEDERHALTER	TUBO
8	2	GOC000A074	3/8 MM	ADATTATORE	ADAPTER	ADAPTATEUR	ADAPTER	ADAPTADOR
9	2	GOC000M006	44411	RONDELLA	WASHER	RONDELLE	SCHEIBE	ARANDELA
10	1	GLD000B375	1/4"R2L3900FDF90	TUBAZIONE	PIPE	TUBE	FEDERHALTER	TUBO
11	4	GOC000A105	Ø 25	COLLARE	PIPE CLAMP	COLLIER	KRAGEN	COLLAR
12	2	GLD000C008	501.30.51	TUBAZIONE	PIPE	TUBE	FEDERHALTER	TUBO
13	1	GOS000A059	SD 14/1	DISTRIBUTORE	DISTRIBUTOR	DISTRIBUTEUR	HANDLER	DISTRIBUIDOR
14	1	GLD000B367	1"R2L1250FDF90	TUBAZIONE	PIPE	TUBE	FEDERHALTER	TUBO
15	1	GLD000B385	1"R2L1300FDF90	TUBAZIONE	PIPE	TUBE	FEDERHALTER	TUBO
16	1	GOS000A082	SD 5/4	DISTRIBUTORE	DISTRIBUTOR	DISTRIBUTEUR	HANDLER	DISTRIBUIDOR
17	2	GOC000A020	1" 1" MM	RACCORDO	CONNECTOR	RACCORD	VERBINDEINHEIT	UNIÓN
18	2	GOC000M004	1"	RONDELLA	WASHER	RONDELLE	SCHEIBE	ARANDELA
19	2	GOC000A010	44411	RACCORDO	CONNECTOR	RACCORD	VERBINDEINHEIT	UNIÓN
20	6	GCB000A018	M10x30	VITE	SCREW	VIS	SCHRAUBE	TORNILLO
21	1	GOS000B006	650.46.00	MOTORE	MOTOR	MOTEUR	MOTOR	MOTOR
22	2	GOC000M003	1/4"	RONDELLA	WASHER	RONDELLE	SCHEIBE	ARANDELA
23	1	GOC000A093	44287	VITE	SCREW	VIS	SCHRAUBE	TORNILLO
24	1	GOC000A008	1/4" MF	PROLUNGA	EXTENSION	RALLONGE	VERLAENGERUNG	PROLONGACIÓN
25	1	GLD000B372	1/4"R1L5300FDFD	TUBAZIONE	PIPE	TUBE	FEDERHALTER	TUBO
26	1	GOD000D043	501.13.00	MARTINETTO	CYLINDER	CYLINDER	ZYLINDER	GATO
28	1	GLD000B401	1/4"R1L1400M-OC	TUBAZIONE	PIPE	TUBE	FEDERHALTER	TUBO
31	1	GOS000A086		LEVA	LEVER	LEVIER	HEBEL	PALANCA
32	6	GOS000A053	C2500	CAVO	CABLE	CABLE	KABEL	CABLE
33	4	GOS000A088		LEVA	LEVER	LEVIER	HEBEL	PALANCA
34	5	GOS000A008		LEVA	LEVER	LEVIER	HEBEL	PALANCA
35	4	GCB000A089	8x25	VITE	SCREW	VIS	SCHRAUBE	TORNILLO
37	1	GSC200B054	420.11.00	SUPPORTO	BRACKET	SUPPORT	SUPPORT	SOPORTE
38	1	GOS000A049		COMANDI	COMMANDS	COMMANDES	BEFEHLE	COMANDOS
39	1	GOS000A028		COMANDI	COMMANDS	COMMANDES	BEFEHLE	COMANDOS
40	3	GCB000A115	M8x60	VITE	SCREW	VIS	SCHRAUBE	TORNILLO
41	2	GCB000A090	8x35	VITE	SCREW	VIS	SCHRAUBE	TORNILLO



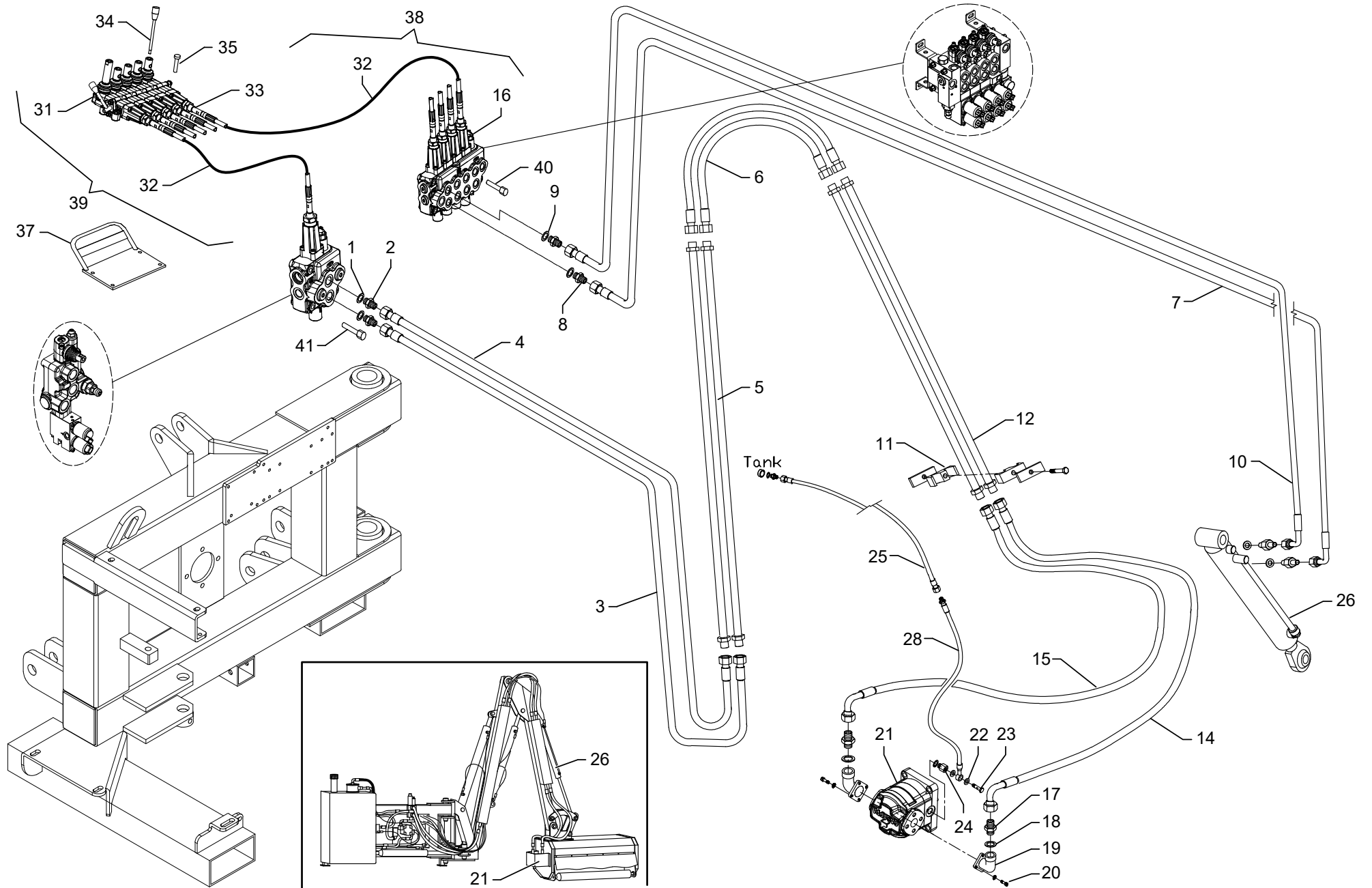

Pos.	Qty	Codice	Disegno	Descrizione	Description	Descripción	Beschreibung	Designation
1	1	GOS000E002		SCAMBIATORE	EXCHANGE	ECHANGEUR	WAERMEAUSTAUSCHER	INTERCAMBIADOR
2	2	GCB000A013	M12X40	VITE	SCREW	VIS	SCHRAUBE	TORNILLO
3	1	GOS000A081		DISTRIBUTORE	DISTRIBUTOR	DISTRIBUTEUR	HANDLER	DISTRIBUIDOR
4	4	GCB000D003	12	ROSETTA	WASHER	RONDELLE	SCHEIBE	ROSETA
5	2	GCB000B008	12	DADO	NUT	ECROU	MUTTER	TUERCA
6	1	GOC000A011	3/8 MM	ADATTATORE	ADAPTER	ADAPTATEUR	ADAPTER	ADAPTADOR
7	1	GOC000M002	44228	RONDELLA	WASHER	RONDELLE	SCHEIBE	ARANDELA
8	1	GOC000M001	44228	RONDELLA	WASHER	RONDELLE	SCHEIBE	ARANDELA
9	1	GOS000E101		TERMOSTATO	THERMOSTAT	THERMOSTAT	THERMOSTAT	TERMOSTATO
10	2	GOC000M004	1"	RONDELLA	WASHER	RONDELLE	SCHEIBE	ARANDELA
11	2	GOC000A020	1" 1" MM	RACCORDO	CONNECTOR	RACCORD	VERBINDEINHEIT	UNIÓN
12	1	GLD000B447	1"R1L950FDF90	TUBAZIONE	PIPE	TUBE	FEDERHALTER	TUBO
13	1	GLD000B365	1"R1L700FDF90	TUBAZIONE	PIPE	TUBE	FEDERHALTER	TUBO
14	1	GOC000A071	1 1/4" - 1" MM	RIDUZIONE	NIPLES	NIPLES	NIPLES	NIPLES
15	1	GOC000M005	1 1/4"	RONDELLA	WASHER	RONDELLE	SCHEIBE	ARANDELA

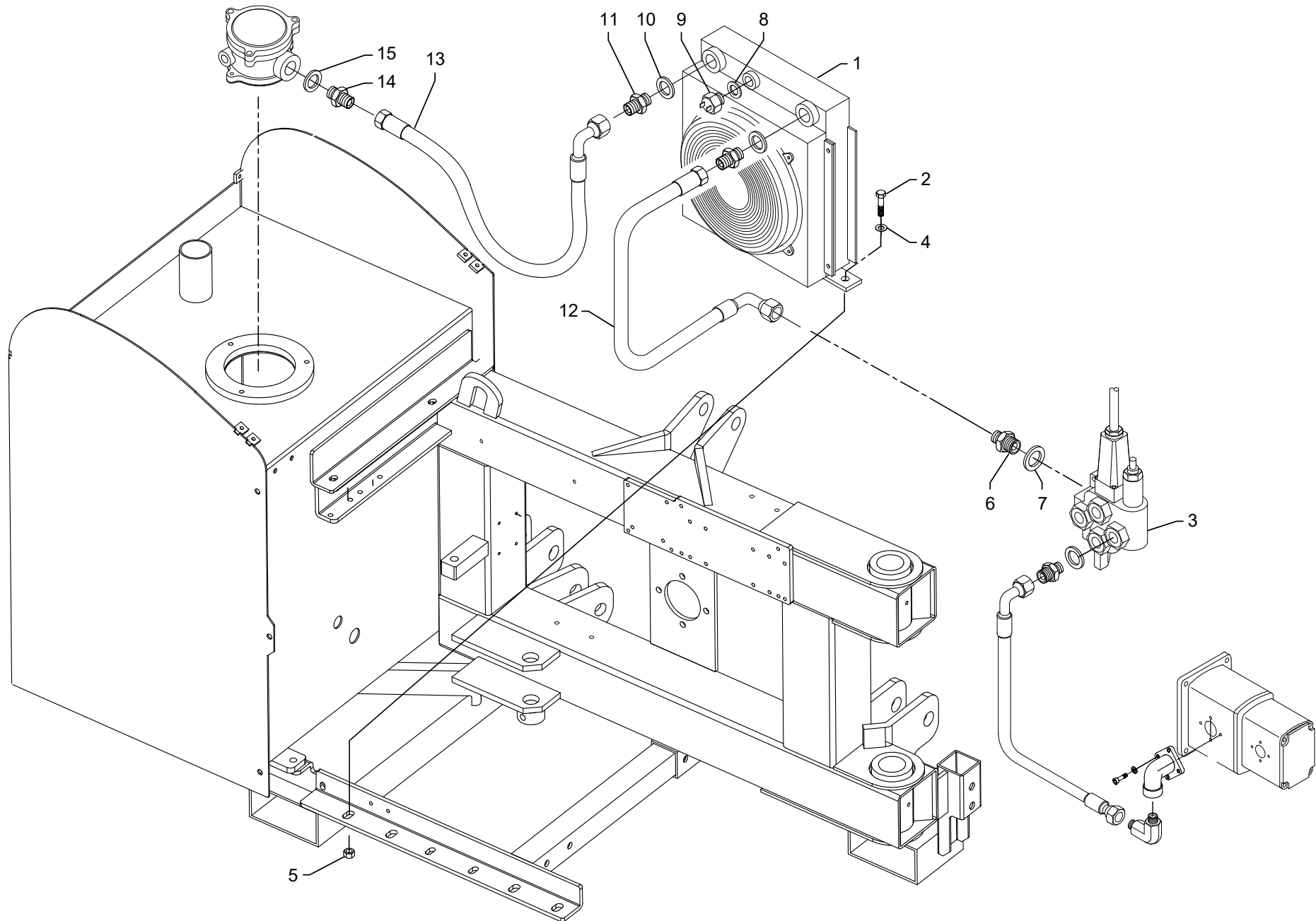

Pos.	Qty	Codice	Disegno	Descrizione	Description	Descripción	Beschreibung	Designation
2	1	GOC000A055	1/4 MMF	RACCORDO	CONNECTOR	RACCORD	VERBINDEINHEIT	UNIÓN
3	1	GLD000B901	1/4R2L550FDF90	TUBAZIONE	PIPE	TUBE	FEDERHALTER	TUBO
4	1	GOS000A023		VALVOLA	VALVE	SOUPAPE	VENTIL	VÁLVULA
6	5	GOC000M003	1/4"	RONDELLA	WASHER	RONDELLE	SCHEIBE	ARANDELA
7	1	GOC000A182	1/4" - 1/4" OR	RACCORDO	CONNECTOR	RACCORD	VERBINDEINHEIT	UNIÓN
8	2	GOC000A093	44287	VITE	SCREW	VIS	SCHRAUBE	TORNILLO
9	1	GLD000B003	1/4"R1L1200FDOC	TUBAZIONE	PIPE	TUBE	FEDERHALTER	TUBO
11	2*	GOC000A077	MM 1/4 18X1,5	RACCORDO	CONNECTOR	RACCORD	VERBINDEINHEIT	UNIÓN
12	2	GCB000A006	M8x25	VITE	SCREW	VIS	SCHRAUBE	TORNILLO
13	1	GSC200B167	530.14.35	STAFFA	BRACKET	ÉTRIER	STEIGBÜGEL	ESTRIBO
14	1	GOS000F002		ACCUMULATORE	ACCUMULATOR	ACCUMULATEUR	AKKUMULATOR	ACUMULADOR
16	2	GCB000A133	M6x65	VITE	SCREW	VIS	SCHRAUBE	TORNILLO

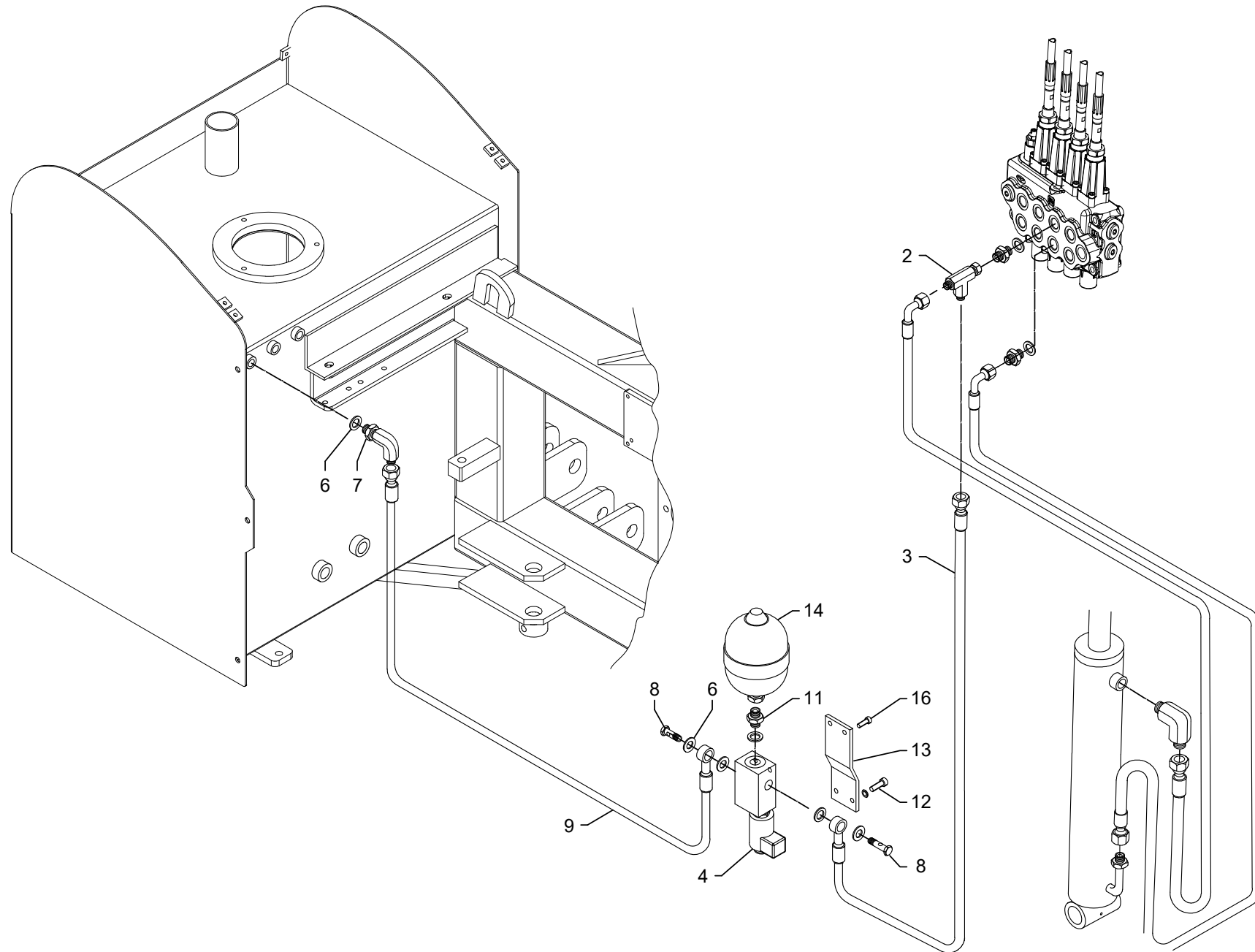

Pos.	Qty	Codice	Disegno	Descrizione	Description	Descripción	Beschreibung	Designation
1	1	GSC200B123	501.14.00	TELAIO	FRAME	CHASSIS	RAHMEN	CHASIS
2	1	ADT600P500		TIRANTE	ROD	TRINGLE	ZUGSTUECK	TIRANTE
3	2	GST100D004		PERNO	PIN	AXE	ACHSE	PERNO
5	1	ARS001P050	85.01.00 (D25)	ATTACCO	ATTACH	JUNCTION	HALTERUNG	ENGANCHE
5	1	ARS001P100	(D32)	ATTACCO	ATTACH	JUNCTION	HALTERUNG	ENGANCHE
5	1	ARS001P060	(D29)	ATTACCO	ATTACH	JUNCTION	HALTERUNG	ENGANCHE

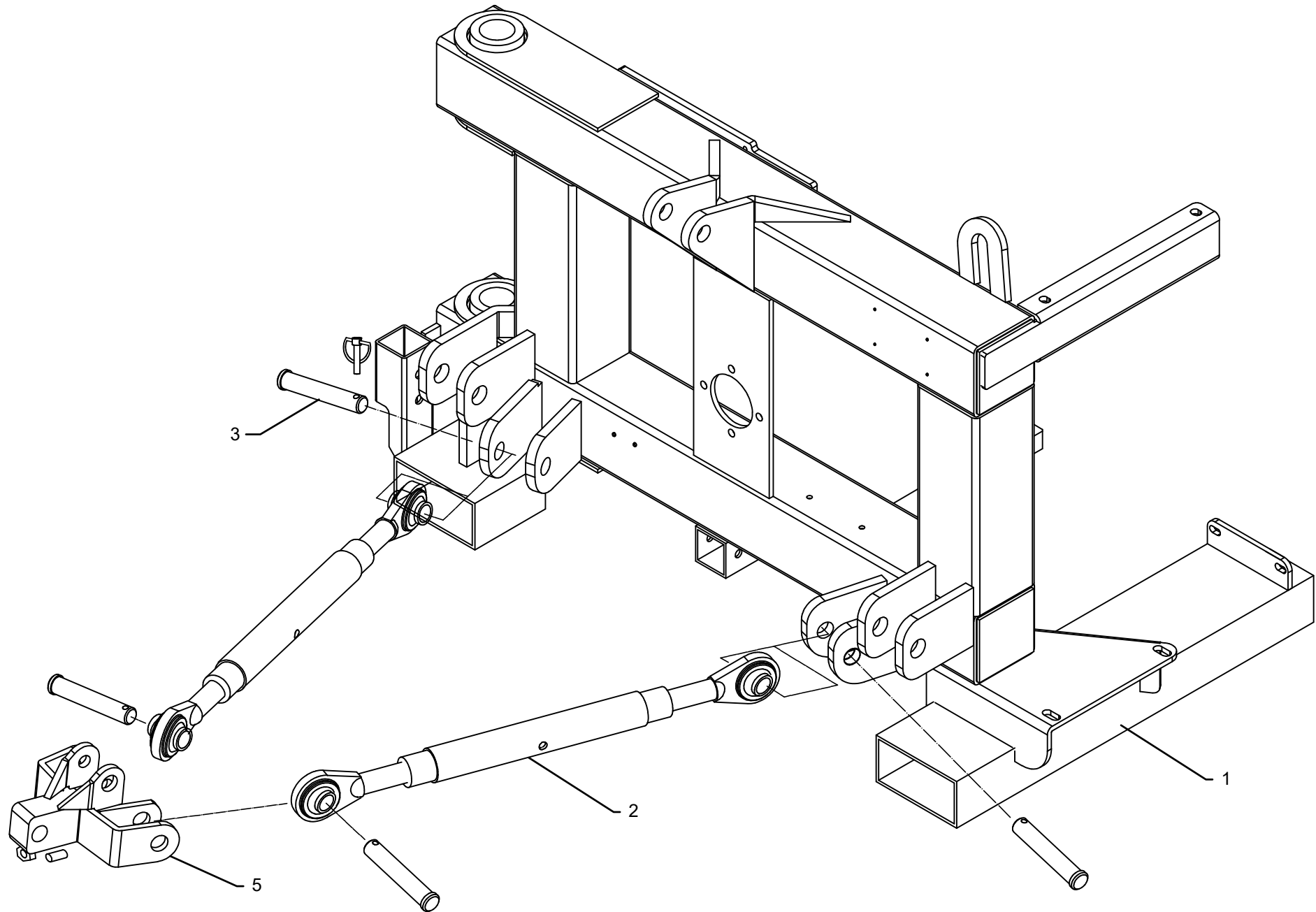



## **Tifermec Oleodinamica S.r.l.**

Via C. Marx, 2/A | 06012 - Cerbara di Città di Castello (PG) Italy

Tel.: +39 075 851.03.76 | Fax: +39 075 851.82.26

[tifermec@tifermec.com](mailto:tifermec@tifermec.com)

[www.tifermec.com](http://www.tifermec.com)