



Grader

Ref. 09.NB.2300/2500/2700



Grader

Ref. 09.NB .2300/2500/2700



- Hydraulic grader attachable to mini-loaders or skid steer loaders. Ideal for spreading material for jobsite ground leveling and preparation. Suitable for the construction of warehouses, sporting fields, landscaping, etc.
- Electrohydraulic controls for smooth and precise operation.
- Hydraulic blade side shift (Standard)
- Excellent visibility. With the most innovative features on the market.
- Laser leveling control (Optional)
- Highest quality steel, with specially hardened (450 Brinell) bolt-on cutting edge.
- Each unit individually tested on electrohydraulic test stand.

| Technical Specifications | | | |
|--------------------------|--------------------------|------------|------------|
| | 09.NB.2300 | 09.NB.2500 | 09.NB.2700 |
| A (in) | 92.91 | | |
| B (in) | 58.27 | | |
| C (in) | 5.51 | | |
| D (in) | 12.20 | | |
| E (in) | 48.43 | | |
| F (in) | 74.21 | 80.71 | 87.01 |
| G (in) | 90.55 | 98.43 | 106.30 |
| H (in) | 8.86 | | |
| I | 35° | | |
| J | 32° (Left) - 32° (Right) | | |
| K (in) | 22.44 | 24.41 | 26.38 |
| Tires | 18 x 8.5 - 8 | | |
| Weight (lbs.) | 1475 | 1500 | 1520 |

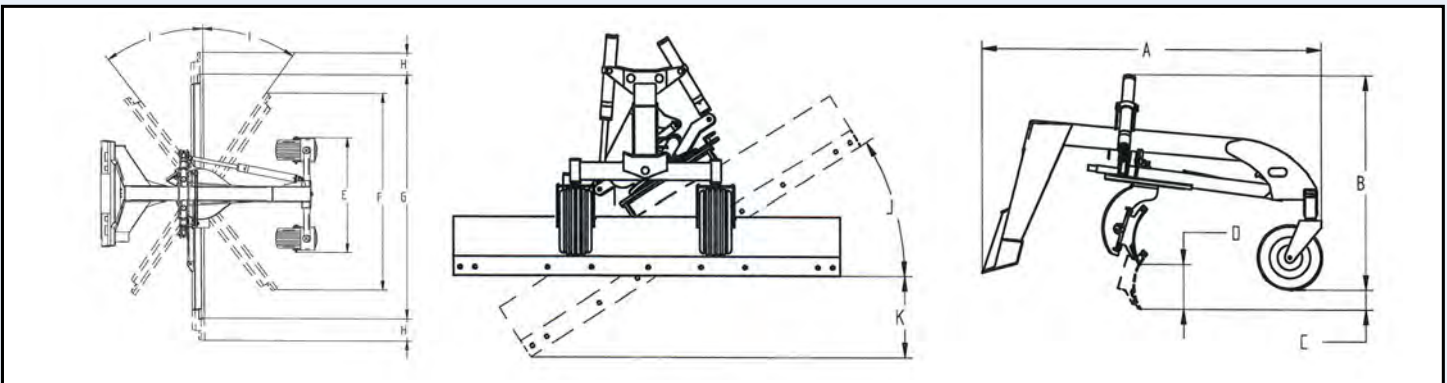

All specifications and technical data subject to change without prior notice.



OFFICE
6535 NW 84th Ave.
Miami, Florida, 33167
Tel. +1-786-542-6122
info@coneac.com
www.coneac.com



Factory
Pol. Ind. La Pobla, nave 19-21
08260 Súria (BCN) SPAIN
Tel. +34 93 869 40 50 - Fax +34 93 868 25 77
euroimplementos@euroimplementos.com
www.euroimplementos.com



Empresa Certificada
UNE-EN-ISO 9001