

Stratus

by

MAXILATOR
EQUIPMENT

Forklift Work Platform

- Safely lift workers for tasks not suitable for ladders
- Easily breaks down for out of the way storage and easy transportation
- Meets OSHA standards
- Secures to forks with two safety pins
- Rustproof thermoplastic finish
- Slip resistant flooring
- Fall arrest anchorages for two workers or 1000-pound capacity

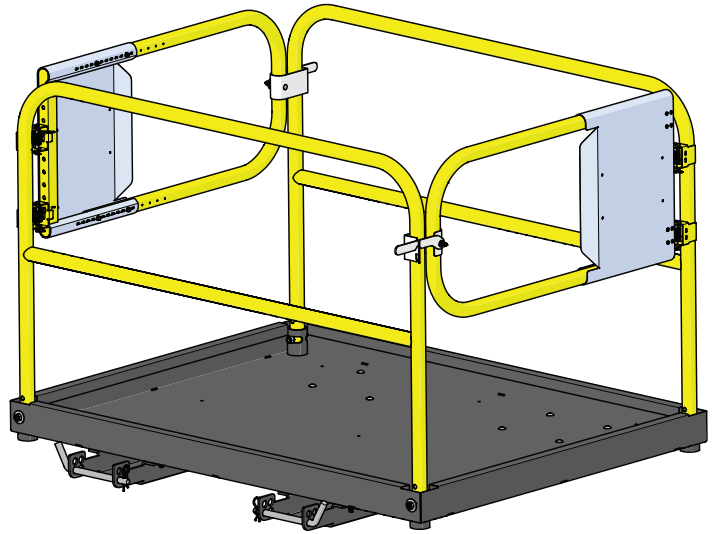

Made In The **USA**

Built with safety in mind for all kinds of overhead work Maxilator's Stratus Forklift Work Platform is a simple design that meets workplace safety requirements for overhead work in warehouses, around farms and in workshops where working on a ladder may be difficult unsafe or impossible. The Stratus work platform is built to last and provide years of safe working conditions.

Specifications

Height: 44.3"

Length: 62.8"

Width: 56.0"

Weight: 225 lbs.

Capacity: 1,000 lbs.

- Max capacity is 1,000 pounds.
- The gate latch must also be closed/secured to conform with OSHA standards.
- When using fall arrest anchorages, forklifts should be rated for loads greater than 6000 pounds for single person operation or 11000 pounds for 2 person operation.

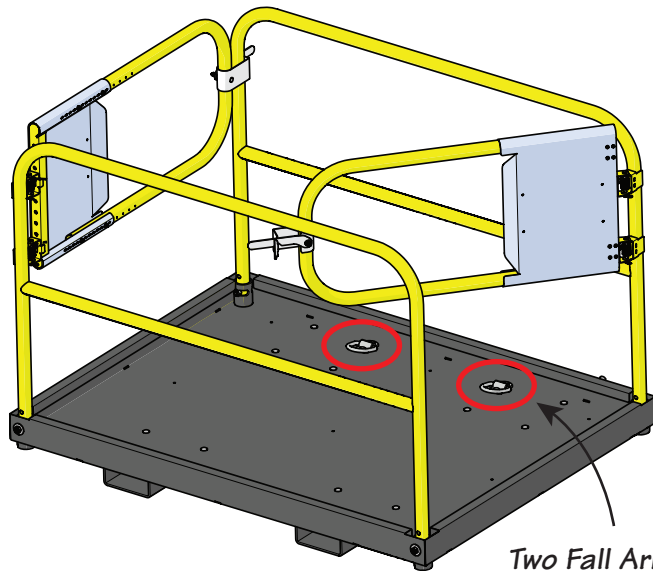

Two Fall Arrest
Anchor Points

If you need parts, service, or technical support please call us at 1-888-200-6278 or email: info@maxilator.com.

MAXILATOR
EQUIPMENT

1-866-HAYBALE (1-866-429-2253)
WWW.MAXILATOR.COM + INFO@MAXILATOR.COM