



McMILLEN
BY PALADIN

OPERATOR'S MANUAL

AUGER DRIVES X6075, X8075 High Torque & 8K2 Two Speed



SERIAL NUMBER: _____

MODEL NUMBER: _____

Manual Number: OM723

Part Number: 75623

Rev. 6

TABLE OF CONTENTS

X6075, X8075 & 8K2 AUGER DRIVES

PREFACE	3
SAFETY PRECAUTIONS	
SAFETY STATEMENTS	5
GENERAL SAFETY PRECAUTIONS	5-7
EQUIPMENT SAFETY PRECAUTIONS	8-9
DECALS	10
INSTALLATION	11-13
HYDRAULIC SYSTEM HOOK-UP INSTRUCTIONS	14
OPERATING INSTRUCTIONS	
8K2 TWO SPEED AUGER DRIVE	15
OPERATION	15-16
STORAGE	16
LIFT POINTS	17
TIE DOWN POINTS	17
TRANSPORTATION	17
MAINTENANCE	
LUBRICATION	18
ROUTINE MAINTENANCE	18
PLANETARY GEARBOX	19
OPTIONS	
AUGER OPTIONS	21-23
AUGER WEAR PARTS	24
TROUBLESHOOTING	25
SPECIFICATIONS	26
PARTS / LIMITED WARRANTY	27

**THIS PAGE
IS INTENTIONALLY
BLANK**

PREFACE

GENERAL COMMENTS

Congratulations on the purchase of your new attachment! This product was carefully designed and manufactured to give you many years of dependable service. Only minor maintenance (such as cleaning and lubricating) is required to keep it in top working condition. Be sure to observe all maintenance procedures and safety precautions in this manual and on any safety decals located on the product and on any equipment on which the attachment is mounted.

This manual has been designed to help you do a better, safer job. Read this manual carefully and become familiar with its contents.

WARNING!  **Never let anyone operate this unit without reading the "Safety Precautions" and "Operating Instructions" sections of this manual. Always choose hard, level ground to park the vehicle on and set the brake so the unit cannot roll.**

Unless noted otherwise, right and left sides are determined from the operator's control position when facing the attachment.

NOTE: The illustrations and data used in this manual were current (according to the information available to us) at the time of printing, however, we reserve the right to redesign and change the attachment as may be necessary without notification.

BEFORE OPERATION

The primary responsibility for safety with this equipment falls to the operator. Make sure the equipment is operated only by trained individuals that have read and understand this manual. If there is any portion of this manual or function you do not understand, contact your local authorized dealer or the manufacturer to obtain further assistance. Keep this manual available for reference. Provide the manual to any new owners and/or operators.

SAFETY ALERT SYMBOL



This is the "Safety Alert Symbol" used by this industry. This symbol is used to warn of possible injury. Be sure to read all warnings carefully. They are included for your safety and for the safety of others working with you.

SERVICE

Use only manufacturer replacement parts. Substitute parts may not meet the required standards.

Record the model and serial number of your unit on the cover of this manual. The parts department needs this information to insure that you receive the correct parts.

SOUND AND VIBRATION

Sound pressure levels and vibration data for this attachment are influenced by many different parameters: some items are listed below (not inclusive):

- prime mover type, age, condition, with or without cab enclosure and configuration
- operator training, behavior, stress level
- job site organization, working material condition, environment

Based on the uncertainty of the prime mover, operator, and job site, it is not possible to get precise machine and operator sound pressure levels or vibration levels for this attachment.

NOTE: A list of all Paladin Patents can be found at <http://www.paladinattachments.com/patents.asp>.

M-1643 7-31-13-3

**THIS PAGE
IS INTENTIONALLY
BLANK**

SAFETY STATEMENTS



THIS SYMBOL BY ITSELF OR WITH A WARNING WORD THROUGHOUT THIS MANUAL IS USED TO CALL YOUR ATTENTION TO INSTRUCTIONS INVOLVING YOUR PERSONAL SAFETY OR THE SAFETY OF OTHERS. FAILURE TO FOLLOW THESE INSTRUCTIONS CAN RESULT IN INJURY OR DEATH.



DANGER

THIS SIGNAL WORD INDICATES A HAZARDOUS SITUATION WHICH, IF NOT AVOIDED, WILL RESULT IN DEATH OR SERIOUS INJURY.



WARNING

THIS SIGNAL WORD INDICATES A HAZARDOUS SITUATION WHICH, IF NOT AVOIDED, COULD RESULT IN DEATH OR SERIOUS INJURY.



CAUTION

THIS SIGNAL WORD INDICATES A HAZARDOUS SITUATION WHICH, IF NOT AVOIDED, COULD RESULT IN MINOR OR MODERATE INJURY.

NOTICE

NOTICE IS USED TO ADDRESS PRACTICES NOT RELATED TO PHYSICAL INJURY.

GENERAL SAFETY PRECAUTIONS

WARNING!

READ MANUAL PRIOR TO INSTALLATION



Improper installation, operation, or maintenance of this equipment could result in serious injury or death. Operators and maintenance personnel should read this manual, as well as all manuals related to this equipment and the prime mover thoroughly before beginning installation, operation, or maintenance. **FOLLOW ALL SAFETY INSTRUCTIONS IN THIS MANUAL AND THE PRIME MOVER'S MANUAL(S).**



READ AND UNDERSTAND ALL SAFETY STATEMENTS

Read all safety decals and safety statements in all manuals prior to operating or working on this equipment. Know and obey all OSHA regulations, local laws, and other professional guidelines for your operation. Know and follow good work practices when assembling, maintaining, repairing, mounting, removing, or operating this equipment.



KNOW YOUR EQUIPMENT

Know your equipment's capabilities, dimensions, and operations before operating. Visually inspect your equipment before you start, and never operate equipment that is not in proper working order with all safety devices intact. Check all hardware to ensure it is tight. Make certain that all locking pins, latches, and connection devices are properly installed and secured. Remove and replace any damaged, fatigued, or excessively worn parts. Make certain all safety decals are in place and are legible. Keep decals clean, and replace them if they become worn or hard to read.

GENERAL SAFETY PRECAUTIONS

WARNING!



PROTECT AGAINST FLYING DEBRIS

Always wear proper safety glasses, goggles, or a face shield when driving pins in or out, or when any operation causes dust, flying debris, or any other hazardous material.

WARNING!



LOWER OR SUPPORT RAISED EQUIPMENT

Do not work under raised booms without supporting them. Do not use support material made of concrete blocks, logs, buckets, barrels, or any other material that could suddenly collapse or shift positions. Make sure support material is solid, not decayed, warped, twisted, or tapered. Lower booms to ground level or on blocks. Lower booms and attachments to the ground before leaving the cab or operator's station.

WARNING!



USE CARE WITH HYDRAULIC FLUID PRESSURE

Hydraulic fluid under pressure can penetrate the skin and cause serious injury or death. Hydraulic leaks under pressure may not be visible. Before connecting or disconnecting hydraulic hoses, read your prime mover's operator's manual for detailed instructions on connecting and disconnecting hydraulic hoses or fittings.

- Keep unprotected body parts, such as face, eyes, and arms as far away as possible from a suspected leak. Flesh injected with hydraulic fluid may develop gangrene or other permanent disabilities.
- If injured by injected fluid, see a doctor at once. If your doctor is not familiar with this type of injury, ask him or her to research it immediately to determine proper treatment.
- Wear safety glasses, protective clothing, and use a piece of cardboard or wood when searching for hydraulic leaks. **DO NOT USE YOUR HANDS! SEE ILLUSTRATION.**

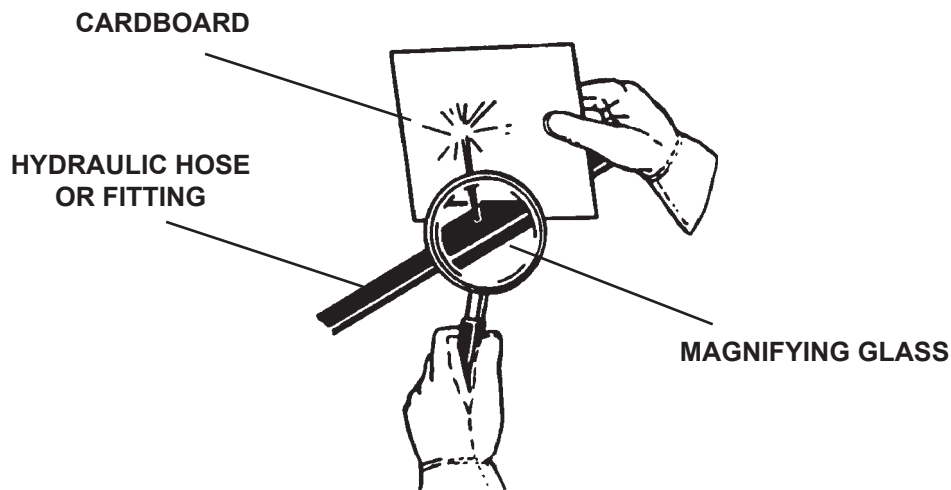

GENERAL SAFETY PRECAUTIONS

WARNING!



DO NOT MODIFY MACHINE OR ATTACHMENTS

Modifications may weaken the integrity of the attachment and may impair the function, safety, life, and performance of the attachment. When making repairs, use only the manufacturer's genuine parts, following authorized instructions. Other parts may be substandard in fit and quality. Never modify any ROPS (Roll Over Protection Structure) or FOPS (Falling Object Protective Structure) equipment or device. Any modifications must be authorized in writing by the manufacturer.

WARNING!



SAFELY MAINTAIN AND REPAIR EQUIPMENT

- Do not wear loose clothing or any accessories that can catch in moving parts. If you have long hair, cover or secure it so that it does not become entangled in the equipment.
- Work on a level surface in a well-lit area.
- Use properly grounded electrical outlets and tools.
- Use the correct tools for the job at hand. Make sure they are in good condition for the task required.
- Wear the protective equipment specified by the tool manufacturer.



SAFELY OPERATE EQUIPMENT

Do not operate equipment until you are completely trained by a qualified operator in how to use the controls, know its capabilities, dimensions, and all safety requirements. See your machine's manual for these instructions.

- Keep all step plates, grab bars, pedals, and controls free of dirt, grease, debris, and oil.
- Never allow anyone to be around the equipment when it is operating.
- Do not allow riders on the attachment or the prime mover.
- Do not operate the equipment from anywhere other than the correct operator's position.
- Never leave equipment unattended with the engine running, or with this attachment in a raised position.
- Do not alter or remove any safety feature from the prime mover or this attachment.
- Know your work site safety rules as well as traffic rules and flow. When in doubt on any safety issue, contact your supervisor or safety coordinator for an explanation.

WARNING!



CALIFORNIA PROPOSITION 65 WARNING

This product may contain a chemical known to the state of California to cause cancer, or birth defects or other reproductive harm. www.P65Warnings.ca.gov

EQUIPMENT SAFETY PRECAUTIONS

WARNING!



KNOW WHERE UTILITIES ARE

Observe overhead electrical and other utility lines. Be sure equipment will clear them. When digging, call your local utilities for location of buried utility lines, gas, water, and sewer, as well as any other hazard you may encounter.

WARNING!



EXPOSURE TO RESPIRABLE CRYSTALLINE SILICA DUST ALONG WITH OTHER HAZARDOUS DUSTS MAY CAUSE SERIOUS OR FATAL RESPIRATORY DISEASE.

It is recommended to use dust suppression, dust collection and if necessary personal protective equipment during the operation of any attachment that may cause high levels of dust.

WARNING!



REMOVE PAINT BEFORE WELDING OR HEATING

Hazardous fumes/dust can be generated when paint is heated by welding, soldering or using a torch. Do all work outside or in a well ventilated area and dispose of paint and solvent properly. Remove paint before welding or heating.

When sanding or grinding paint, avoid breathing the dust. Wear an approved respirator. If you use solvent or paint stripper, remove stripper with soap and water before welding. Remove solvent or paint stripper containers and other flammable material from area. Allow fumes to disperse at least 15 minutes before welding or heating.

WARNING!



END OF LIFE DISPOSAL

At the completion of the useful life of the unit, drain all fluids and dismantle by separating the different materials (rubber, steel, plastic, etc.). Follow all federal, state and local regulations for recycling and disposal of the fluid and components.



OPERATING THE AUGER

- All bystanders should be kept a minimum of 10 feet (3 meters) away from the working area of the earth auger.
- Operate only from the operator's station.
- Avoid steep hillside operation which could cause the prime mover to overturn. Consult your prime mover operator's and safety manuals for maximum incline allowable.
- Reduce speed when driving over rough terrain, on a slope, or turning, to avoid overturning the vehicle.
- An operator must not use drugs or alcohol, which can change his or her alertness or coordination. An operator taking prescription or over-the-counter drugs should seek medical advice on whether or not he or she can safely operate equipment.
- Before exiting the prime mover, lower the attachment to the ground, apply the parking brakes, turn off the prime mover's engine, and remove the key.
- Flow and pressure gauges, fittings, and hoses must have a continuous operating pressure rating of at least 25% higher than highest pressures of the system.

EQUIPMENT SAFETY PRECAUTIONS



TRANSPORTING THE AUGER

- Travel only with the earth auger in a safe transport position to prevent uncontrolled movement. Drive slowly over rough ground and on slopes.
- Tether the earth auger with a chain, if necessary, to prevent uncontrolled swinging of the auger when moving from hole to hole.
- Do not drive close to ditches, excavations, etc., cave in could result.
- Do not smoke when refueling the prime mover. Allow room in the fuel tank for expansion. Wipe up any spilled fuel. Secure cap tightly when done.
- Remove the earth auger from the prime mover before transporting to and from the job site.



MAINTAINING THE AUGER

- Before performing maintenance, lower the attachment to the ground, apply the parking brakes, turn off the engine, and remove the key.
- Never adjust a relief valve for pressure higher than recommended by the prime mover manufacturer.
- Never perform any work on an attachment unless you are authorized and qualified to do so. Always read the operator service manual's before any repair is made. After completing maintenance or repair, check for correct functioning of the attachment. If not functioning properly, always tag "DO NOT OPERATE" until all problems are corrected.
- Worn, damaged, or illegible safety decals must be replaced. New safety decals can be ordered from McMillen® free of charge.
- Never make hydraulic repairs while the system is under pressure. Serious personal injury or death could occur.

DECALS

GENERAL INFORMATION

The following decals are reductions of the actual decals used on auger drives. Use this information to order replacements for lost or damaged decals. Be sure you understand all decals before operating the attachment. They contain information you need to know for attachment safety.

IMPORTANT: Keep all safety decals clean and legible. Replace all missing, or damaged safety decals. When replacing parts with safety decals attached, the safety decals must also be replaced.

REPLACING SAFETY DECALS: Clean the area of application with a nonflammable solvent, then wash the same area with soap and water. Allow the surface to dry. Remove the backing from the safety decal, exposing the adhesive surface. Apply the safety decal to the position shown in the diagram, and smooth out any bubbles.

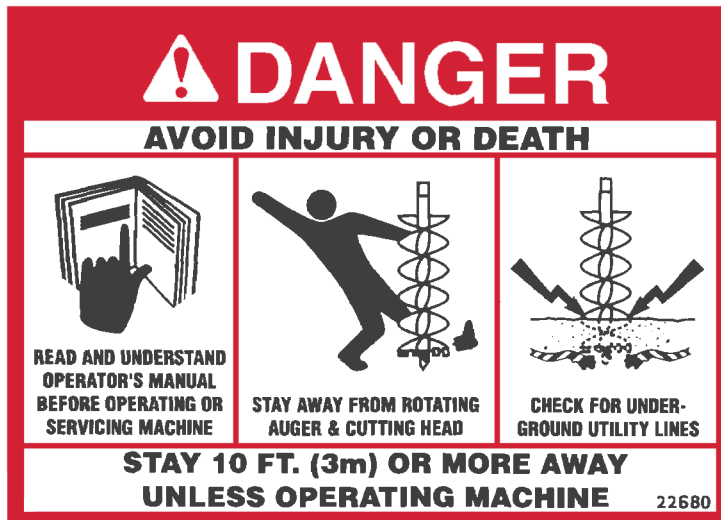

PART #22680
DANGER DECAL
(LOCATED ON THE MOTOR/PLANETARY HOUSING)

NOTE: CONTACT YOUR LOCAL DEALER TO PURCHASE LOGO AND MODEL NUMBER DECALS.

INSTALLATION INSTRUCTIONS

GENERAL INFORMATION

Find the mounting kit diagram and parts list for the kit you have received. Study the diagram and familiarize yourself with the names of the various parts. This knowledge will assist you in understanding these instructions.

Read these instructions carefully before attempting to mount the auger.

READ AND UNDERSTAND ALL SAFETY INFORMATION PRIOR TO MOUNTING YOUR AUGER.

QUICK ATTACH MOUNTING ASSEMBLIES

(Includes Skid Steer Loader Mounts.)

1. Remove the bucket or other attachment from the prime mover quick attach mechanism.
2. Attach the quick attach mounting bracket to the prime mover quick attach mechanism, as per manufacturer's recommendations.
3. Attach the swivel (#23835) to the quick attach mounting bracket with pin (#23839) provided. Secure the pin in place with safety pin (#10040).
4. If your mounting bracket is designed for the installation of a cradle, bolt the cradle to the bracket using the .50" UNC X 2.00" capscrews, lock washers and hex nuts provided.
5. Install the drive unit to the swivel using the pin provided with the drive unit assembly.
6. Install the auger to the drive unit with the bolt and nut provided with the drive unit assembly.
7. Refer to the **"HYDRAULIC SYSTEM HOOK-UP"** section in this manual for hydraulic connection instructions and recommendations.

BACKHOE AND EXCAVATOR "PENDULUM" MOUNTING ASSEMBLIES

1. Remove the bucket from the dipper arm and curl cylinder pin connections. The dipper arm pin will be used to attach auger pendulum mounting to the dipper arm. Curl cylinder pin will not be required for auger installation.
2. Attach the pendulum mounting (all types) to the dipper using the dipper arm pin removed from the bucket in Step #1. Secure the bucket pin as per prime mover manufacturer's recommendation.

M-1753 11-21-07

INSTALLATION INSTRUCTIONS

4. Install the auger drive unit to pendulum mount with pivot pin provided with the drive unit assembly.
5. Install the auger to the drive unit with the bolt and nut provided with the drive unit assembly.
6. Refer to the **“HYDRAULIC SYSTEM HOOK-UP”** section in this manual for hydraulic connection instructions and recommendations.

BACKHOE AND EXCAVATOR “PIN GRABBER” MOUNTING ASSEMBLIES

1. Remove the bucket from the dipper arm and curl cylinder pin connections.
2. Attach the pin grabber mounting (all types) to the dipper and curl cylinder using the pivot pins and cotter pins provided.
3. Attach the swivel (#23835) to the pin grabber mounting bracket with pivot pin provided. Secure the pin in place with safety pin (#10040).
4. If your mounting bracket is designed for the installation of a cradle, bolt the cradle to the bracket using the .50” UNC X 2.00” capscrews, lock washers and hex nuts provided.
5. Install the drive unit to the swivel using the pin provided with the drive unit assembly.
6. Install the auger to the drive unit with the bolt and nut provided with the drive unit assembly.
7. Refer to the **“HYDRAULIC SYSTEM HOOK-UP”** section in this manual for hydraulic connection instructions and recommendations.

WELD-ON EXCAVATOR MOUNTING

McMillen offers a blank weld on plate with mounting ears and swivel for welding onto your own excavator mounting bracket.

After securely welding the plate onto your bracket:

INSTALLATION INSTRUCTIONS

1. Attach the swivel (#23835) to the mounting plate with pivot pin #23839 provided. Secure the pin in place with safety pin #10040.
2. Install the drive unit to the swivel using the pin provided with the drive unit assembly.
3. Install the auger to the drive unit with the bolt and nut provided with the drive unit assembly.
4. Refer to the **“HYDRAULIC SYSTEM HOOK-UP”** section in this manual for hydraulic connection instructions and recommendations.

WARNING! REMOVE PAINT BEFORE WELDING OR HEATING.



Hazardous fumes/dust can be generated when paint is heated by welding, soldering or using a torch. Do all work outside or in a well ventilated area and dispose of paint and solvent properly. Remove paint before welding or heating.

When sanding or grinding paint, avoid breathing the dust. Wear an approved respirator. If you use solvent or paint stripper, remove stripper with soap and water before welding. Remove solvent or paint stripper containers and other flammable material from area. Allow fumes to disperse at least 15 minutes before welding or heating.

HYDRAULIC SYSTEM HOOK-UP INSTRUCTIONS

GENERAL INFORMATION

Once the installation instructions are complete, you are now ready to make the hydraulic connections necessary to operate your earth drill.

READ AND UNDERSTAND SAFETY INFORMATION PRIOR TO MAKING HYDRAULIC CONNECTIONS.

Your equipment dealer is in the best position to advise you as to where the best place on your machine is to make the hydraulic connections to power your earth drill drive unit. The list below shows the most common places to “tap” into the hydraulic system on various types of machines.

- **SKID STEER LOADERS** - Auxiliary hydraulic outlets.
- **BACKHOES & EXCAVATORS** - Auxiliary hydraulic outlets or bucket curl cylinder circuit.
- **WHEEL LOADERS & TRACTOR LOADERS** - Auxiliary hydraulic outlets or bucket tilt (dump) cylinder circuit.

Determine the length of hydraulic hoses required to plumb drive unit into the place on your machine where you will be “tapping” into the hydraulics. Be sure the two hydraulic hoses are long enough to perform at the full range of the earth drill’s operating capacity. A case drain line will also be required to operate your earth drill.

- **Models X4075, X5075, X6075, X8075 & 8K2** - These models require two 3/4” (19mm) ID hydraulic hoses, with #12 JIC Female fittings on one end of each hose, to connect hoses to drive unit fittings. **A case drain line is also required.** The skid steer hydraulic kits for the high torque auger drives include a case drain line. An excavator Drain Line Kit is available through your local dealer.

NOTE: Fittings on the other end of each hydraulic hose should match the threads on the hydraulic quick couplers to be used.

WARNING! HOSES AND FITTINGS MUST HAVE A CONTINUOUS OPERATING PRESSURE RATING OF AT LEAST 25% HIGHER THAN THE HIGHEST PRESSURES OF THE SYSTEM YOU ARE “TAPPING” INTO.



Once all of the hydraulic connections have been made and checked for leaks, you are now ready to operate your earth drill. **READ AND UNDERSTAND OPERATING INSTRUCTIONS AND SAFETY INFORMATION PRIOR TO OPERATING YOUR EARTH DRILL.**

OPERATING INSTRUCTIONS

All three auger drives dig the same except the 8K2 has an additional two speed “shift on demand” feature.

8K2 TWO SPEED AUGER DRIVE:

An increased demand on the auger drive will cause the pressure of the operating vehicle to increase. When the pressure of the prime mover exceeds 2500 PSI (preset) the 8K2 motor will automatically shift to maximum displacement, which reduces the speed of the auger and increases the torque. When the pressure decreases and goes below 1000 PSI the motor will shift back to minimum displacement which will increase the speed of the auger and decrease the torque.

OPERATION

1. After all installation instructions have been completed, safety information read and understood, and the rest of this operator’s manual has been reviewed, your McMillen Hydraulic Earth Drill is now ready for use.
2. With the auger raised off the ground and the vehicle engine set at a low RPM, activate the earth drill control valve to determine which position the control valve lever must be in to turn auger in a forward (clockwise) rotation. This is the “digging” position.
3. Before beginning to dig, experiment with auger speed to determine a suitable auger RPM. Generally in light and sandy soil a high RPM is desirable. In hard, rocky, or frozen soils a slower RPM is desirable. To increase auger RPM, increase vehicle engine RPM. To decrease auger RPM, decrease vehicle engine RPM.
4. Return earth drill control valve to neutral position to stop the auger. Lower the auger to the ground so that only the center point penetrates the ground about 2” (51mm).
5. Activate the earth drill control valve so auger is turning in a forward (clockwise) rotation. Use only enough down pressure to assure positive penetration of auger into the ground. Ease up on down pressure if auger rotation slows down drastically or stalls.

NOTE: Excessive down pressure will cause the auger to stall frequently.

6. When auger has penetrated the ground about 24” (610mm), raise the auger from the hole to clean the dirt out. Repeat this procedure until the desired hole depth is obtained.
7. Once the required hole depth is reached, allow the auger to turn a few seconds at this depth to clean the hole.
8. Return the earth drill control valve to the neutral position to stop the rotation of the auger. Raise the auger out of the hole, move away from the hole, then activate the earth drill control valve to spin the loose soil off of the augers.

NOTE: Do not reverse the auger rotation to remove from the hole as loose soil on the auger flights will fall back into the hole.

OPERATING INSTRUCTIONS

9. If necessary, repeat steps 7 & 8 to obtain a cleaner hole.
10. In some soil conditions or when excessive down pressure is applied, auger may “screw” itself into the ground and become stuck causing earth drill to stall. If this happens, reverse the auger rotation (counter-clockwise) by moving the control valve lever to the reverse position and slowly raise the auger. Once unstuck, return the control valve lever to the forward rotation position and continue digging.
11. If the auger becomes lodged under rocks, roots, or other large obstructions, do not attempt to raise the auger out of the ground. See step 10 for proper procedure to relieve the auger.
12. Avoid excessive side loading to earth drill which can cause drive unit or auger damage.
13. Keep auger teeth and points in good condition. Check frequently and always keep spares on hand so they can be replaced as wear is detected to avoid damage to tooth holders and auger flighting.

WARNING: To prevent possible injury or death, keep all bystanders 10 feet or more away from rotating auger. Take extra precautions when digging in locations where any type of landscape fabric may be present.



STORAGE

- Check that drive unit motor and hoses are full of clean oil and planetary is full.
- Coat liberally with grease the output shaft and collar, extension shaft and collar, and all connecting pins to prevent rust and reduce wear.
- Clean the unit thoroughly, removing all mud, dirt, and grease.
- Inspect for visible signs of wear, breakage, or damage. Order any parts required and make the necessary repairs to avoid delays upon removal from storage.
- Tighten loose nuts, capscrews and hydraulic connections.
- Seal hydraulic system from contaminants and secure all hydraulic hoses off the ground to help prevent damage.
- Replace decals that are damaged or in unreadable condition.
- Store unit in a dry and protected place. Leaving the unit outside will materially shorten its life.

Additional Precautions for Long Term Storage:

- Touch up all unpainted surfaces with paint to prevent rust.

REMOVAL FROM STORAGE

- Remove cover.
- Wash unit and replace any damage and/or missing parts .
- Check hydraulic hoses for damage and replace as necessary.

OPERATING INSTRUCTIONS

LIFT POINTS

Lifting points are identified by lifting decals where required. Lifting at other points is unsafe and can damage attachment. Do not attach lifting accessories around cylinders or in any way that may damage hoses or hydraulic components.

- Attach lifting accessories to unit at recommended lifting points.
- Bring lifting accessories together to a central lifting point.
- Lift gradually, maintaining the equilibrium of the unit.

WARNING!  Use lifting accessories (chains, slings, ropes, shackles and etc.) that are capable of supporting the size and weight of your attachment. Secure all lifting accessories in such a way to prevent unintended disengagement. Failure to do so could result in the attachment falling and causing serious personal injury or death.

TIE DOWN POINTS

Tie down points are identified by tie down decals where required. Securing to trailer at other points is unsafe and can damage attachment. Do not attach tie down accessories around cylinders or in any way that may damage hoses or hydraulic components.

- Attach tie down accessories to unit as recommended.
- Check unit stability before transporting.

WARNING!  Verify that all tie down accessories (chains, slings, ropes, shackles and etc.) are capable of maintaining attachment stability during transporting and are attached in such a way to prevent unintended disengagement or shifting of the unit. Failure to do so could result in serious personal injury or death.

TRANSPORTING

Follow all local government regulations that may apply along with recommended tie down points and any equipment safety precautions at the front of this handbook when transporting your attachment.

MAINTENANCE

GENERAL INFORMATION

Your McMillen earth drill was designed to be virtually maintenance free. Very little effort is needed to keep it in top working condition. It is however, important to follow these procedures to get full performance and longevity out of the unit.

LUBRICATION

Change planetary gear reduction oil with API-GL-5, 80W or 90W lubricant after the first 50 hours of operation and then every 1000 hours or 12 months, whichever comes first.

Procedure	Daily	After First 50 Hours	1000 Hours or 12 Months
Check Hydraulic Oil for Contamination	✓		
Inspect Hydraulic Hoses for damage, leaking and/or signs of excessive heat. Replace if necessary.	✓		
Check Auger Point and Teeth for excessive wear or loose fit. Replace if necessary.	✓		
Check Drive Unit output shaft for excessive wear, damage or leakage. Replace if necessary.	✓		
Check all bolts and pivot pins for damage, breaks or wear. Replace if necessary.	✓		
Check all Accessories (Extensions, Collars)	✓		
Change Planetary Oil		✓	✓

CAUTION!  **EXCESSIVE VENTING OF LUBRICANT FROM PLANETARY MAY INDICATE THAT THE MOTOR SHAFT SEAL IS LEAKING. UNIT SHOULD BE REPAIRED IMMEDIATELY.**

PLANETARY SHAFT SEAL REPLACEMENT IS THE ONLY PLANETARY REPAIR THAT CAN BE MADE WHILE THE UNIT IS UNDER WARRANTY. (SEE PARTS PAGES FOR PLANETARY SEAL NUMBER.)

MOTOR SHAFT SEAL REPLACEMENT IS THE ONLY HYDRAULIC MOTOR REPAIR THAT CAN BE MADE WHILE THE UNIT IS UNDER WARRANTY. (SEE PARTS PAGES FOR MOTOR SEAL NUMBER.)

MAINTENANCE

PLANETARY GEARBOX

Change gear box oil using API-GL-5, 80W or 90W lubricant after the first 50 hours of operation and then every 1000 hours or 12 months, whichever comes first. Check oil level frequently to maintain proper lubrication. Oil should be at operating temperature when checking or changing gear box oil.

NOTE: Place planetary in a horizontal position and wait 5 minutes before removing drain plug. This will give the oil a chance to drain from gears/bearings and therefore show an accurate oil level.

CHECKING PLANETARY LUBRICANT (DIGGA PLANETARIES)

1. Place the planetary in a horizontal position.
2. Remove drain plug.
3. Check the lubricant level. Gear lub level should be visible through the drain plug port and up to the bottom of the threads.
4. To Fill: Place the planetary in a horizontal position and add lubricant up to the threads of drain plug hole. Do not overfill. Oil capacity is approximately .62 (5/8) quarts.

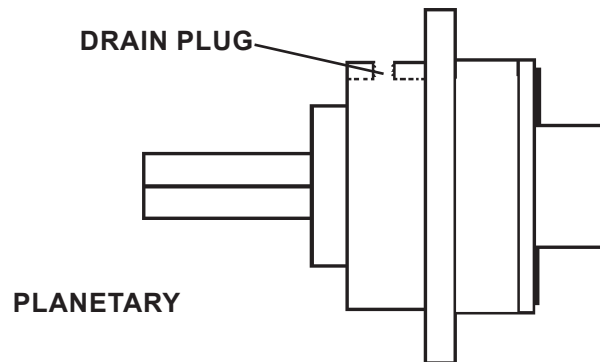

CHECKING PLANETARY LUBRICANT (AUBURN PLANETARIES)

1. Place the planetary in a horizontal position.
2. Remove drain plug.
3. Check the lubricant level. Gear lub level should be visible through the drain plug port and up to the bottom of the threads.
4. To Fill: Place the planetary in a horizontal position and add lubricant up to the threads of drain plug port. Do not overfill. Oil capacity is approximately .75 (3/4) quarts.

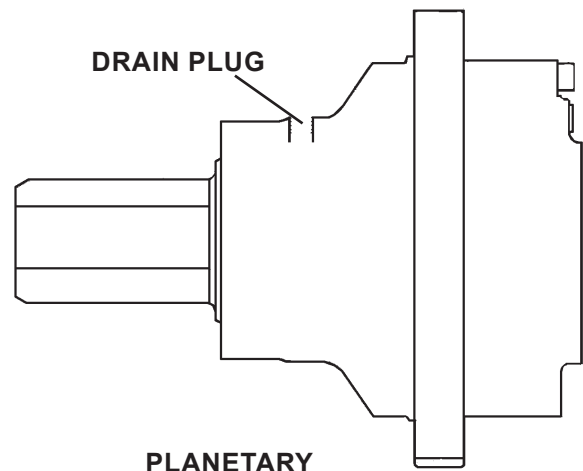

M-1728 2-6-20-5

**THIS PAGE
IS INTENTIONALLY
BLANK**

AUGER OPTIONS

2" HEX AUGERS

AUGER SIZE	HDF <i>(light to moderate ground conditions)</i>	HDC <i>(difficult ground conditions)</i>	HTF <i>(tree and shrub planting)</i>	HDR <i>(soid, fracturable rock & frozen ground)</i>
4" x 3'	20000	--	--	--
6" x 3'	20018	20033	--	--
8" x 3'	20053	20068	--	--
9" x 3'	20092	20109	--	--
10" x 3'	20142	20157	--	--
12" x 3'	20180	20198	--	--
15" x 3'	20234	20251	--	--
16" x 3'	20266	20280	--	--
18" x 3'	20302	20318	--	--
20" x 3'	20347	20360	--	--
24" x 3'	20383	20397	--	--
30" x 3'	20426	20438	--	--
36" x 3'	20471	20483	--	--
 				
4" x 4'	20003	--	--	--
6" x 4'	20021	20036	--	20046
8" x 4'	20056	20071	--	--
9" x 4'	20096	20113	--	20124
10" x 4'	20145	20160	--	20169
12" x 4'	20183	20201	--	20214
15" x 4'	20237	20254	--	--
16" x 4'	20269	20283	--	20293
18" x 4'	20306	20321	20334	20332
20" x 4'	20350	20363	--	20372
24" x 4'	20386	20401	20414	20412
30" x 4'	20429	20441	20454	20451
36" x 4'	20474	20486	20499	20497
42" x 4'	--	20512	20515	--
48" x 4'	--	20523	20525	--
 				
4" x 5'	20007	--	--	--
6" x 5'	20027	20040	--	--
8" x 5'	20061	20075	--	--
9" x 5'	20103	20117	--	--
10" x 5'	20151	20163	--	--
12" x 5'	20190	20205	--	--
15" x 5'	20243	20257	--	--
16" x 5'	20274	20286	--	--
18" x 5'	20311	20325	--	--
20" x 5'	20354	20366	--	--
24" x 5'	20390	20404	--	--
30" x 5'	20432	20444	--	--
36" x 5'	20477	20489	--	--
 				
4" x 6'	20010	--	--	--
6" x 6'	20030	20043	--	--
8" x 6'	20064	20078	--	--
9" x 6'	20106	20120	--	--
10" x 6'	20154	20166	--	--
12" x 6'	20193	20208	--	--
15" x 6'	20246	20260	--	--
16" x 6'	20277	20289	--	--
18" x 6'	20314	20328	--	--
20" x 6'	20357	20369	--	--
24" x 6'	20393	20407	--	--
30" x 6'	20435	20447	--	--
36" x 6'	20480	20492	--	--

AUGER OPTIONS

2.50" HEX AUGERS

AUGER SIZE		MDC Standard Teeth	MDC Carbide Teeth
8" x 103"	40" of Flighting	20084	20085
9" x 103"	40" of Flighting	20132	20133
10" x 103"	40" of Flighting	20173	20174
12" x 103"	40" of Flighting	20221	20222
14" x 103"	40" of Flighting	20230	20231
16" x 103"	40" of Flighting	20297	20298
18" x 103"	40" of Flighting	20340	20341
20" x 103"	40" of Flighting	20376	20377
24" x 103"	40" of Flighting	20420	20421
30" x 103"	40" of Flighting	20461	20462
36" x 103"	40" of Flighting	23311	20507
42" x 103"	40" of Flighting	20519	20520
48" x 103"	40" of Flighting	20530	20531
8" x 103"	60" of Flighting	20086	20087
9" x 103"	60" of Flighting	20134	20135
10" x 103"	60" of Flighting	20175	20176
12" x 103"	60" of Flighting	20223	20224
14" x 103"	60" of Flighting	20232	20233
16" x 103"	60" of Flighting	20299	20300
18" x 103"	60" of Flighting	20342	20344
20" x 103"	60" of Flighting	20378	20379
24" x 103"	60" of Flighting	20422	20423
30" x 103"	60" of Flighting	20463	20464
36" x 103"	60" of Flighting	20508	20509
42" x 103"	60" of Flighting	20521	20522
48" x 103"	60" of Flighting	20532	20533

AUGER OPTIONS

EXTENSIONS

DESCRIPTION	FIXED LENGTH	VARIABLE LENGTH
12" x 2" Hex	22839	23105
18" x 2" Hex	22845	23111
24" x 2" Hex	22851	23117
48" x 2" Hex	22858	23126
72" x 2" Hex	22865	23135
24" x 2" Hex HD Tube	22852	--
48" x 2" Hex HD Tube	22859	--
72" x 2" Hex HD Tube	22866	--
72" x 2.50" Hex	22868	23137

ADAPTERS

PART #	DRIVE UNIT	AUGER COLLAR
21969	2" HEX	2" ROUND
21987	2" HEX	2.56" ROUND
21989	2" HEX	2.50" HEX
24546	2" HEX	2.62" HEX

WEAR PARTS

PART #	DESCRIPTION	HDF	HDC	HTF	HDR	MDC
22190	Fishtail Point 3.50"	X	X	X		
22003	Fishtail Point 4.50"	X				
22169	Gage Tooth – Outside	X	X	X		
22168	Wisdom Tooth – Inside	X	X	X		
22306	.62" Bolt	X		X		
1839	.62" Nut	X		X		
22154	Rubber Lock		X			
22201	Rock Tooth				X	
22176	Dirt Pilot – Standard					X
22160	Gage Tooth – Outside					X
22158	Dirt Tooth – Inside					X
22177	Carbide Pilot					X
22163	Carbide Gage Tooth - Outside					X
22162	Carbide Tooth – Inside					X

HDC STYLE AUGER WEAR PARTS LIST

AUGER DIA.	6"	8"	9"	10"	12"	15"	16"	18"	20"	24"	30"	36"	42"	48"
Part #	152mm	203mm	229mm	254mm	305mm	381mm	406mm	457mm	508mm	610mm	762mm	914mm	1067mm	1219mm
Description(Standard Components)	Hardened Drive-In Gage Tooth	Hardened Drive-In Gage Tooth	Hardened Drive-In Gage Tooth	Hardened Drive-In Gage Tooth	Hardened Drive-In Gage Tooth	Hardened Drive-In Gage Tooth	Hardened Drive-In Gage Tooth	Hardened Drive-In Gage Tooth	Hardened Drive-In Gage Tooth	Hardened Drive-In Gage Tooth	Hardened Drive-In Gage Tooth	Hardened Drive-In Gage Tooth	Hardened Drive-In Gage Tooth	Hardened Drive-In Gage Tooth
	2	2	2	2	2	2	2	2	2	2	2	2	2	2
	-	2	2	2	2	4	4	4	4	6	8	10	14	18
	1	1	1	1	1	1	1	1	1	1	1	1	1	1
	2	4	4	4	4	6	6	6	6	8	10	12	16	20

HDF STYLE AUGER WEAR PARTS LIST

AUGER DIA.	4"	6"	8"	9"	10"	12"	15"	16"	18"	20"	24"	30"	36"
Part #	102mm	152mm	203mm	229mm	254mm	305mm	381mm	406mm	457mm	508mm	610mm	762mm	914mm
Description(Standard Components)	Hardened Bolt-on Gage Tooth	Hardened Bolt-on Gage Tooth	Hardened Bolt-on Gage Tooth	Hardened Bolt-on Gage Tooth	Hardened Bolt-on Gage Tooth	Hardened Bolt-on Gage Tooth	Hardened Bolt-on Gage Tooth	Hardened Bolt-on Gage Tooth	Hardened Bolt-on Gage Tooth	Hardened Bolt-on Gage Tooth	Hardened Bolt-on Gage Tooth	Hardened Bolt-on Gage Tooth	Hardened Bolt-on Gage Tooth
	-	2	2	2	2	2	2	2	2	2	2	2	2
	-	-	-	1	1	2	3	3	4	4	6	7	9
	-	1	1	1	1	1	1	1	1	1	1	1	1
	1	-	-	-	-	-	-	-	-	-	-	-	-
	-	2	2	3	3	4	5	5	6	6	8	9	11
	-	2	2	3	3	4	5	5	6	6	8	9	11

HTF STYLE AUGER WEAR PARTS LIST

AUGER DIA.	18"	24"	30"	36"	42"	48"
Part #	457mm	610mm	762mm	914mm	1067mm	1219mm
Description(Standard Components)	Hardened Bolt-on Gage Tooth	Hardened Bolt-on Gage Tooth	Hardened Bolt-on Gage Tooth	Hardened Bolt-on Gage Tooth	Hardened Bolt-on Gage Tooth	Hardened Bolt-on Gage Tooth
	4	4	4	4	4	4
	3	6	7	9	11	13
	1	1	1	1	1	1
	7	10	11	13	15	17
	7	10	11	13	15	17

OPTIONAL HARDFACED & CARBIDE WEAR COMPONENTS

Part #	Description
22170	Hardfaced Wisdom Tooth
22186	Carbide Wisdom Tooth
22181	Hardened Chisel Tooth
22183	Hardfaced Chisel Tooth
22182	Carbide Chisel Tooth
22190	3.50" Hardened Fishtail Point (Male Hub)
22192	3.50" Hardfaced Fishtail Point (Male Hub)
22191	3.50" Carbide Fishtail Point (Male Hub)
22193	3.50" Hardfaced /Carbide Fishtail Point (Male Hub)
22003	4.50" Hardened Fishtail Point (Female)
22004	4.50" Hardfaced Fishtail Point (Female)
22005	4.50" Hardfaced /Carbide Fishtail Point (Female)
22171	3.50" Hardened Fishtail Point (Female)
22172	3.50" Carbide Fishtail Point (Female)
22173	3.50" Hardfaced Fishtail Point (Female)
22174	3.50" Hardfaced /Carbide Fishtail Point (Female)

NOTE: Contact your equipment dealer for wear components not listed above. If you have any special auger needs or applications, feel free to contact McMiller.

IMPORTANT: McMillen does not recommend augers exceeding 36" diameter for C-Series Drive Units.

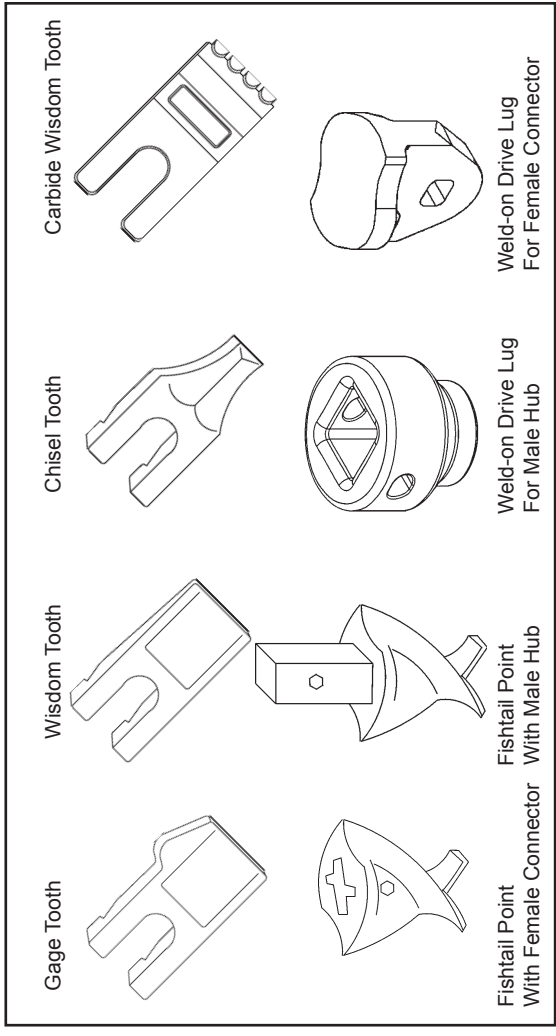

TROUBLESHOOTING

PROBLEM	POSSIBLE CAUSE	POSSIBLE SOLUTION
Slow Speed	Low Flow	Check with flow meter. If low investigate cause.
	Line restrictions	Clear lines
	Fittings or connections too small	Replace with proper sizes.
	Oil filter dirty	Replace
	Hydraulic pump worn or damaged	See Dealer for repair
Insufficient Digging Power	Worn teeth or point	Replace
	Low system Pressure (PSI)	Check with pressure gauge. If low, investigate cause.
	Relief Valve damaged or setting wrong	Adjust or replace as required.
	Excessive load	Reduce load to within machine specifications.
Reverse Direction	Hoses reversed	Re-install hoses correctly.
Excessive Oil Heating	Line restrictions	Clear lines
	Fluid dirty	Replace hydraulic fluid and filter.
	Insufficient quantity of hydraulic fluid	Fill reservoir to proper level. increase reservoir storage capacity.
Oil Leaks	Hoses loose or damaged	Tighten or replace
	Fittings loose or damaged	Tighten or replace
	Hydraulic motor seals worn or damaged	See Dealer for repair.

SPECIFICATIONS

GENERAL INFORMATION

The X6075, X8075 and 8K2 augers require a heavy duty mounting kit with a maximum auger diameter of 48". A hydraulic motor drives the auger through a sealed planetary gear reduction. The heavy duty gear design gives these units a long life with minimal maintenance and service costs. McMillen planetary drives are completely sealed with all moving components running in oil for total lubrication on a constant basis. All models feature reverse rotation for quick backout when obstructions are encountered. The system's hydraulic relief valve protects the units from damage when the auger hits large immovable objects.

DRAIN LINE REQUIRED

MODEL X6075

Maximum Auger Diameter: 48" (1219mm)
 Minimum Hydraulic Flow: 30 gpm (114 lpm)
 Maximum Hydraulic Flow: 53 gpm (201 lpm)
 Maximum Continuous Operating PSI: 3500 psi (246 kg/cm²)
 Output shaft Options: 2" (51mm)Hexagon
 2-1/2" (63.5mm) Hexagon

OUTPUT SPEED		OUTPUT TORQUE	
FLOW	SPEED	PRESSURE	TORQUE
GPM (LPM) =	RPM	PSI (kg/cm ²) =	Lb•Ft (N•m)
30 (114) =	51	2000 (141) =	3624 (4913)
32 (121) =	54	2500 (176) =	4531 (6143)
34 (129) =	57	3000 (211) =	5437 (7372)
36 (136) =	61	3500 (241) =	6343 (8600)
38 (144) =	64		
40 (151) =	68		
42 (159) =	72		
44 (167) =	74		
46 (174) =	78		
48 (182) =	81		
50 (189) =	85		
52 (197) =	88		
53 (201) =	90		

DRAIN LINE REQUIRED

MODEL X8075

Maximum Auger Diameter: 48" (1219mm)
 Minimum Hydraulic Flow: 36 gpm (136 lpm)
 Maximum Hydraulic Flow: 54 gpm (204 lpm)
 Maximum Continuous Operating PSI: 3500 psi (246 kg/cm²)
 Output shaft Options: 2-1/2" (63.5mm)Hexagon

OUTPUT SPEED		OUTPUT TORQUE	
FLOW	SPEED	PRESSURE	TORQUE
GPM (LPM) =	RPM	PSI (kg/cm ²) =	Lb•Ft (N•m)
36 (136) =	42	2000 (141) =	5194 (7042)
38 (144) =	45	2500 (176) =	6493 (8803)
40 (151) =	47	3000 (211) =	7791 (10563)
42 (159) =	50	3500 (241) =	9090 (12324)
44 (167) =	52		
46 (174) =	54		
48 (182) =	57		
50 (189) =	59		
52 (197) =	61		
54 (204) =	64		

DRAIN LINE REQUIRED

MODEL 8K2 (2-SPEED)

Maximum Auger Diameter: 48" (1219mm)
 Minimum Hydraulic Flow: 30 gpm (136 lpm)
 Maximum Hydraulic Flow: 45 gpm (170 lpm)
 Maximum Continuous Operating PSI: 4000 psi (281 kg/cm²)
 Output shaft Options: 2-1/2" (63.5mm)Hexagon

OUTPUT SPEED				OUTPUT TORQUE			
FLOW		SPEED		PRESSURE		TORQUE	
		LOW	HIGH			HIGH	LOW
GPM (LPM) =	RPM	RPM	RPM	PSI (kg/cm ²) =	Lb•Ft (N•m)	Lb•Ft (N•m)	Lb•Ft (N•m)
30 (136) =	33	49		3000 (211) =	8471 (11485)	5647 (7656)	
35 (132) =	38	57		3500 (241) =	9882 (13398)	6588 (8932)	
45 (170) =	49	73		4000 (276) =	11294 (15313)	7529 (10208)	

Output speed and torque specifications are based on theoretical values and are provided for comparative purposes only.

McMillen is continually striving to improve its products. Specifications and design are subject to change without notice and without liability therefor.

M-1733 2-21-08

PARTS

In order to provide you with the most UP-TO-DATE part information, all parts for this attachment have been moved to our website at www.paladinattachments.com/Manuals. Please use these diagrams and parts lists to locate replacement parts.

When servicing your attachment, remember to use only original manufacturer replacement parts. Substitute parts may not meet the standards required for safe, dependable operation.

To facilitate parts ordering when contacting the factory, please have the product control number (PCN) or model and serial number of your product ready to ensure that you receive the correct parts for your specific attachment.

The product control number (PCN), model and serial number for your attachment should be recorded in the space provided on the cover of this manual. This information may be obtained from the serial number identification plate located on your attachment.

NOTE: Most daily and emergency parts orders (in stock) received by 10:30 A.M. (Eastern Standard Time) will be shipped UPS Ground the same day received. UPS Next Day orders must be received by 1:30 PM (Eastern Standard Time.)

SERVICE DEPARTMENT

(734) 996-9116

(800) 456-7100

For Fax and E-mail Orders

PLC_Sales@paladinattachments.com

(734) 996-9014

WARRANTY

In order to provide you with the most UP-TO-DATE Warranty information, Paladin Warranty Statement and Warranty Procedures along with Warranty Registration and Claim Forms have been moved to our website at www.paladinattachments.com.

13033 8-4-16-2