



Backhoe

Ref. OP 00/02/03/3.2/04/05



Backhoe

Ref. OP 00/02/03/3.2/04/05

OP 00



OP 02



OP 02A



OP 03E



Model Designation

A	Agricultural
C	Premium
E	Economy
M	Monoblock



Standard Equipment: Hydraulic side shift lock. 16" Bucket. Machine mounting bracket. 7 section valve with 2 levers, 4 positions each.

Note: OP 00 does not include side shift.

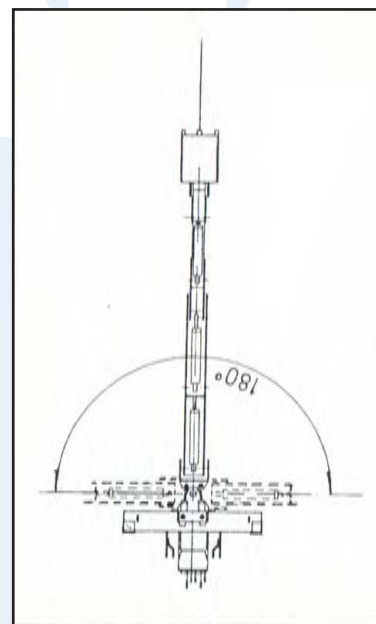

OFFICE
2070 N.W. 79th Ave Suite 204
Miami, FL, 33122
Tel. +1-786-332-4024
info@coneac.com
www.coneac.com



Factory
Pol. Ind. La Pobla, nave 19-21
08260 Súria (BCN) SPAIN
Tel. +34 93 869 40 50 - Fax +34 93 868 25 77
euroimplementos@euroimplementos.com
www.euroimplementos.com



Empresa Certificada
UNE-EN-ISO 9001

Backhoe

Ref. OP 00/02/03/3.2/04/05

OP 03C



OP 03M



OP 04



Buckets with teeth			
Ref. No.	Weight	Capacity (SAE)	Width
CR 200	115 lb		
CR 250	121 lb	*.027/.04 yd ³	
CR 300	128 lb	*.034/.05 yd ³	
CR 400	141 lb	*.047/.07 yd ³	
CR 500	154 lb	.085 yd ³	
CR 600	163 lb	.10 yd ³	
Cleaning Buckets without teeth			
CRL 800	212 lb		31.5 in.
CRL 1000	276 lb		39.3 in.

* Bucket for OP 00 Only

Buckets Per Model					
Ref. No.	OP 00	OP 02	OP 03	OP 3.2	OP 04
CR 200	Yes	Yes	Yes	No	No
CR 250	Yes	Yes	Yes	Yes	Yes
CR 300	Yes	Yes	Yes	Yes	Yes
CR 400	Yes	Yes	Yes	Yes	Yes
CR 500	No	Yes	Yes	Yes	Yes
CR 600	No	Yes	Yes	Yes	Yes
CRL 800	No	Yes	Yes	Yes	Yes
CRL 1000	No	Yes	Yes	Yes	Yes

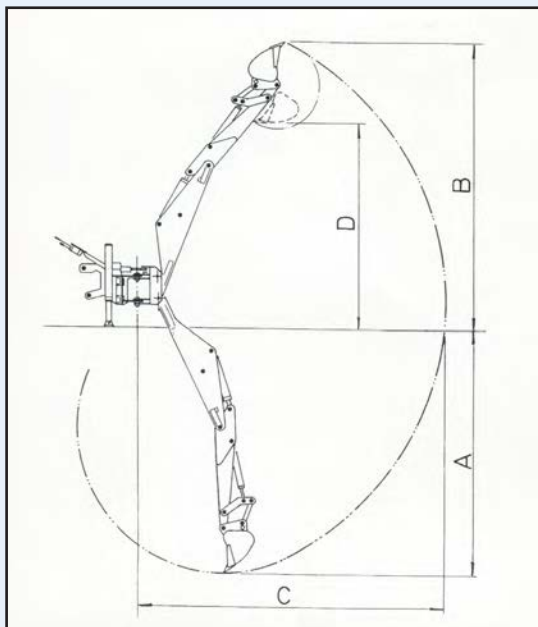
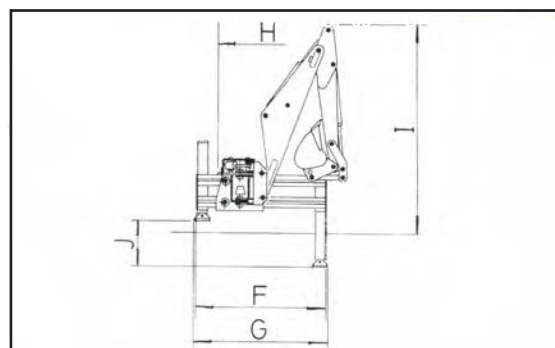

Technical Data	OP 00	OP 02C	OP 03C	OP 03.2	OP 04
A	80 in.	100 in.	80 in.	122 in.	134 in.
B	102 in.	120 in.	80 in.	138 in.	150 in.
C	102 in.	120 in.	80 in.	138 in.	150 in.
D	70 in.	74 in.	80 in.	92 in.	110 in.
E	14 in.	15 in.	15 in.	15 in.	16 in.
F*	33 in.	60 in.	60 in.	60 in.	60 in.
G*	37 in.	64 in.	64 in.	34 in.	64 in.
H*	16 in.	34 in.	34 in.	34 in.	34 in.
I	66 in.	79 in.	89 in.	91 in.	94 in.
J	16 in.	20 in.	20 in.	20 in.	20 in.
Weight	606 lb	1,239 lb	1,565 lb	1,587 lb	1,653 lb

* Different widths available as needed for Carrier.



OFFICE
2070 N.W. 79th Ave Suite 204
Miami, FL, 33122
Tel. +1-786-332-4024
info@coneac.com
www.coneac.com



Factory
Pol. Ind. La Pobra, nave 19-21
08260 Súria (BCN) SPAIN
Tel. +34 93 869 40 50 - Fax +34 93 868 25 77
euroimplementos@euroimplementos.com
www.euroimplementos.com



Empresa Certificada
UNE-EN-ISO 9001

Backhoe

Ref. OP 00/02/03/3.2/04/05

OP 05



Pedestal mounted backhoe for use with included hydraulic hammer in the charge area of rock crushers

Optional Accessories



All specifications and technical data subject to change without prior notice.



OFFICE
2070 N.W. 79th Ave Suite 204
Miami, FL, 33122
Tel. +1-786-332-4024
info@coneac.com
www.coneac.com



Factory
Pol. Ind. La Pobla, nave 19-21
08260 Súria (BCN) SPAIN
Tel. +34 93 869 40 50 - Fax +34 93 868 25 77
euroimplementos@euroimplementos.com
www.euroimplementos.com



Empresa Certificada
UNE-EN-ISO 9001