

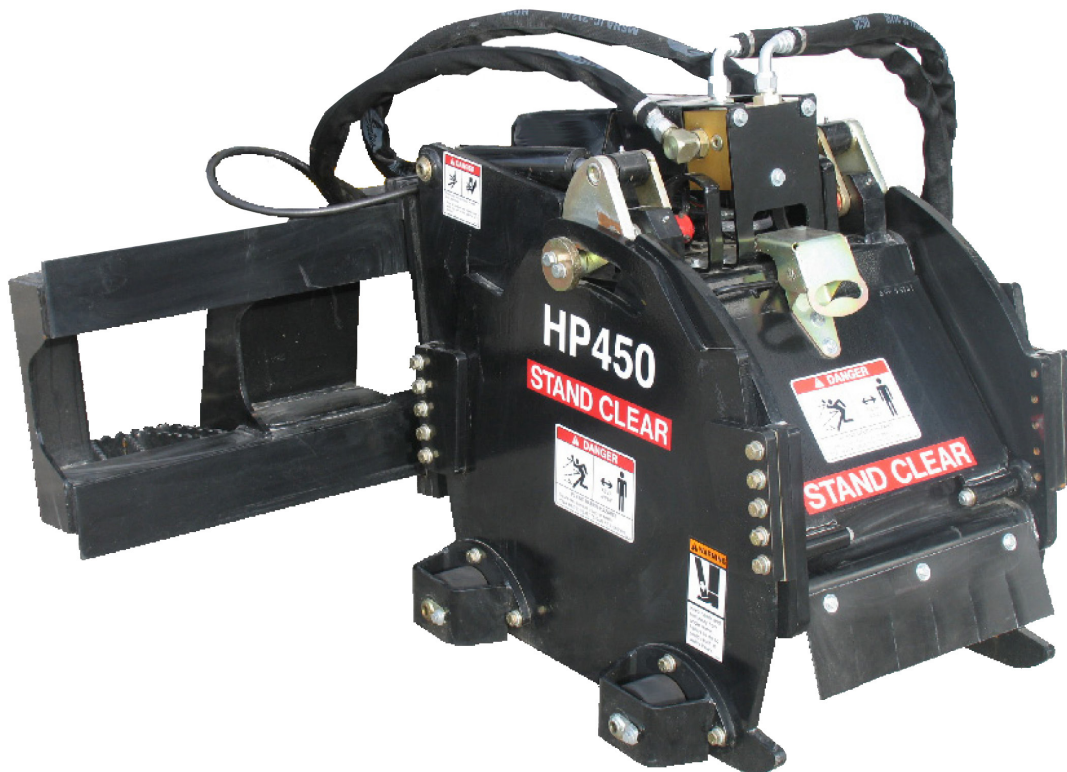

OPERATOR'S MANUAL

COLD PLANER - HIGH FLOW HP400, HP450, HP600, HP750 & HP1000

**FOR
SKID STEER LOADERS**



SERIAL NUMBER: _____

MODEL NUMBER: _____

Manual Number: OM666

Part Number: 75566

Rev. 16

TABLE OF CONTENTS

PREFACE	3
SAFETY PRECAUTIONS	
Safety Statements.....	5
General Safety Precautions.....	5-7
Equipment Safety Precautions.....	8-9
DECALS	
Decal Placement.....	10
Decals.....	11-12
PRE-OPERATION	13-14
INSTALLATION	15-16
OPERATING INSTRUCTIONS	
Controls.....	17-18
Intended Use.....	19
General Operating Instructions.....	19-20
Special Applications.....	21-22
Large Area / Milling Around Manholes / Deep Cuts / Milling Taper Cuts	
Storage.....	23
Lift Points & Tie Down Points.....	23-24
MAINTENANCE AND SERVICE	
Lubrication.....	25
Routine Maintenance.....	26
Pick Replacement.....	27
Changing the Drum.....	28
Changing the Planetary.....	28-29
Changing the Hydraulic Motor.....	29
Hydraulic Reservoir - Troubleshooting.....	30
Cylinder Seal Replacement.....	31-32
TROUBLESHOOTING	33-34
SPECIFICATIONS	
Cold Planer Specifications.....	35
Bolt Torque Specifications.....	36
PARTS / LIMITED WARRANTY	37

**THIS PAGE
IS INTENTIONALLY
BLANK**

PREFACE

GENERAL COMMENTS

Congratulations on the purchase of your new BRADCO product! This product was carefully designed and manufactured to give you many years of dependable service. Only minor maintenance (such as cleaning and lubricating) is required to keep it in top working condition. Be sure to observe all maintenance procedures and safety precautions in this manual and on any safety decals located on the product and on any equipment on which the attachment is mounted.

This manual has been designed to help you do a better, safer job. Read this manual carefully and become familiar with its contents.

WARNING! Never let anyone operate this unit without reading the "Safety Precautions" and "Operating Instructions" sections of this manual.



Always choose hard, level ground to park the vehicle on and set the brake so the unit cannot roll.

Unless noted otherwise, right and left sides are determined from the operator's control position when facing forward.

NOTE: The illustrations and data used in this manual were current (according to the information available to us) at the time of printing, however, we reserve the right to redesign and change the attachment as may be necessary without notification.

BEFORE OPERATION

The primary responsibility for safety with this equipment falls to the operator. Make sure the equipment is operated only by trained individuals that have read and understand this manual. If there is any portion of this manual or function you do not understand, contact your local authorized dealer or the manufacturer to obtain further assistance. Keep this manual available for reference. Provide the manual to any new owners and/or operators.

SAFETY ALERT SYMBOL



This is the "Safety Alert Symbol" used by this industry. This symbol is used to warn of possible injury. Be sure to read all warnings carefully. They are included for your safety and for the safety of others working with you.

SERVICE

Use only manufacturer replacement parts. Substitute parts may not meet the required standards.

Record the model and serial number of your unit on the cover of this manual. The parts department needs this information to insure that you receive the correct parts.

SOUND AND VIBRATION

Sound pressure levels and vibration data for this attachment are influenced by many different parameters: some items are listed below (not inclusive):

- prime mover type, age, condition, with or without cab enclosure and configuration
- operator training, behavior, stress level
- job site organization, working material condition, environment

Based on the uncertainty of the prime mover, operator, and job site, it is not possible to get precise machine and operator sound pressure levels or vibration levels for this attachment.

NOTE: A list of all Paladin Patents can be found at <http://www.paladinattachments.com/patents.asp>.

**THIS PAGE
IS INTENTIONALLY
BLANK**

SAFETY STATEMENTS



THIS SYMBOL BY ITSELF OR WITH A WARNING WORD THROUGHOUT THIS MANUAL IS USED TO CALL YOUR ATTENTION TO INSTRUCTIONS INVOLVING YOUR PERSONAL SAFETY OR THE SAFETY OF OTHERS. FAILURE TO FOLLOW THESE INSTRUCTIONS CAN RESULT IN INJURY OR DEATH.



DANGER

THIS SIGNAL WORD INDICATES A HAZARDOUS SITUATION WHICH, IF NOT AVOIDED, WILL RESULT IN DEATH OR SERIOUS INJURY.



WARNING

THIS SIGNAL WORD INDICATES A HAZARDOUS SITUATION WHICH, IF NOT AVOIDED, COULD RESULT IN DEATH OR SERIOUS INJURY.



CAUTION

THIS SIGNAL WORD INDICATES A HAZARDOUS SITUATION WHICH, IF NOT AVOIDED, COULD RESULT IN MINOR OR MODERATE INJURY.

NOTICE

NOTICE IS USED TO ADDRESS PRACTICES NOT RELATED TO PHYSICAL INJURY.

GENERAL SAFETY PRECAUTIONS

WARNING!

READ MANUAL PRIOR TO INSTALLATION



Improper installation, operation, or maintenance of this equipment could result in serious injury or death. Operators and maintenance personnel should read this manual, as well as all manuals related to this equipment and the prime mover thoroughly before beginning installation, operation, or maintenance. **FOLLOW ALL SAFETY INSTRUCTIONS IN THIS MANUAL AND THE PRIME MOVER'S MANUAL(S).**



READ AND UNDERSTAND ALL SAFETY STATEMENTS

Read all safety decals and safety statements in all manuals prior to operating or working on this equipment. Know and obey all OSHA regulations, local laws, and other professional guidelines for your operation. Know and follow good work practices when assembling, maintaining, repairing, mounting, removing, or operating this equipment.



KNOW YOUR EQUIPMENT

Know your equipment's capabilities, dimensions, and operations before operating. Visually inspect your equipment before you start, and never operate equipment that is not in proper working order with all safety devices intact. Check all hardware to ensure it is tight. Make certain that all locking pins, latches, and connection devices are properly installed and secured. Remove and replace any damaged, fatigued, or excessively worn parts. Make certain all safety decals are in place and are legible. Keep decals clean, and replace them if they become worn or hard to read.

GENERAL SAFETY PRECAUTIONS

WARNING!



PROTECT AGAINST FLYING DEBRIS

Always wear proper safety glasses, goggles, or a face shield when driving pins in or out, or when any operation causes dust, flying debris, or any other hazardous material.

WARNING!



LOWER OR SUPPORT RAISED EQUIPMENT

Do not work under raised booms without supporting them. Do not use support material made of concrete blocks, logs, buckets, barrels, or any other material that could suddenly collapse or shift positions. Make sure support material is solid, not decayed, warped, twisted, or tapered. Lower booms to ground level or on blocks. Lower booms and attachments to the ground before leaving the cab or operator's station.

WARNING!



USE CARE WITH HYDRAULIC FLUID PRESSURE

Hydraulic fluid under pressure can penetrate the skin and cause serious injury or death. Hydraulic leaks under pressure may not be visible. Before connecting or disconnecting hydraulic hoses, read your prime mover's operator's manual for detailed instructions on connecting and disconnecting hydraulic hoses or fittings.

- Keep unprotected body parts, such as face, eyes, and arms as far away as possible from a suspected leak. Flesh injected with hydraulic fluid may develop gangrene or other permanent disabilities.
- If injured by injected fluid, see a doctor at once. If your doctor is not familiar with this type of injury, ask him to research it immediately to determine proper treatment.
- Wear safety glasses, protective clothing, and use a piece of cardboard or wood when searching for hydraulic leaks. **DO NOT USE YOUR HANDS!**
SEE ILLUSTRATION.

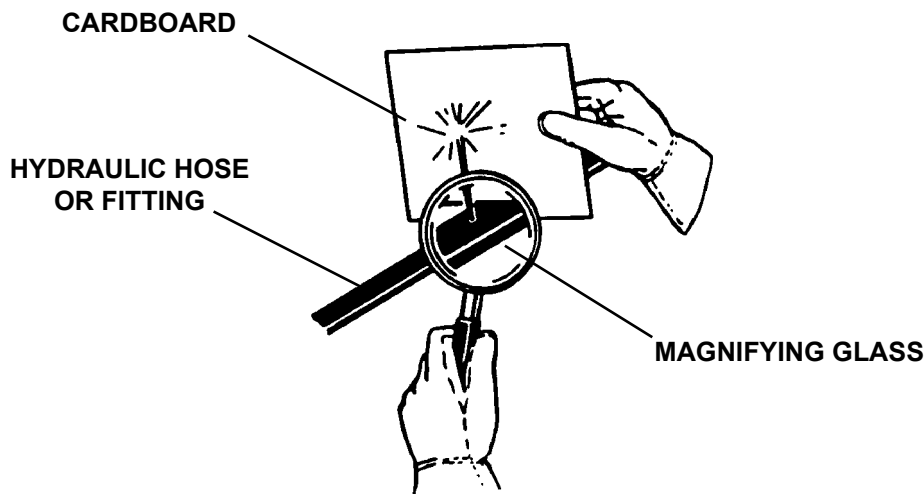

GENERAL SAFETY PRECAUTIONS

WARNING!



DO NOT MODIFY MACHINE OR ATTACHMENTS

Modifications may weaken the integrity of the attachment and may impair the function, safety, life, and performance of the attachment. When making repairs, use only the manufacturer's genuine parts, following authorized instructions. Other parts may be substandard in fit and quality. Never modify any ROPS (Roll Over Protective Structure) or FOPS (Falling Object Protective Structure) equipment or device. Any modifications must be authorized in writing by the manufacturer.

WARNING!



SAFELY MAINTAIN AND REPAIR EQUIPMENT

- Do not wear loose clothing or any accessories that can catch in moving parts. If you have long hair, cover or secure it so that it does not become entangled in the equipment.
- Work on a level surface in a well-lit area.
- Use properly grounded electrical outlets and tools.
- Use the correct tools for the job at hand. Make sure they are in good condition for the task required.
- Wear the protective equipment specified by the tool manufacturer.



SAFELY OPERATE EQUIPMENT

Do not operate equipment until you are completely trained by a qualified operator in how to use the controls, know its capabilities, dimensions, and all safety requirements. See your machine's manual for these instructions.

- Keep all step plates, grab bars, pedals, and controls free of dirt, grease, debris, and oil.
- Never allow anyone to be around the equipment when it is operating.
- Do not allow riders on the attachment or the prime mover.
- Do not operate the equipment from anywhere other than the correct operator's position.
- Never leave equipment unattended with the engine running, or with this attachment in a raised position.
- Do not alter or remove any safety feature from the prime mover or this attachment.
- Know your work site safety rules as well as traffic rules and flow. When in doubt on any safety issue, contact your supervisor or safety coordinator for an explanation.

WARNING!



CALIFORNIA PROPOSITION 65 WARNING

This product may contain a chemical known to the state of California to cause cancer, or birth defects or other reproductive harm. www.P65Warnings.ca.gov

EQUIPMENT SAFETY PRECAUTIONS

WARNING!



KNOW WHERE UTILITIES ARE

Observe overhead electrical and other utility lines. Be sure equipment will clear them. When digging, call your local utilities for location of buried utility lines, gas, water, and sewer, as well as any other hazard you may encounter.

WARNING!



EXPOSURE TO RESPIRABLE CRYSTALLINE SILICA DUST ALONG WITH OTHER HAZARDOUS DUSTS MAY CAUSE SERIOUS OR FATAL RESPIRATORY DISEASE.

This attachment is designed to plane (mill) rock, concrete and asphalt, causing high levels of dust. It is recommended to use dust suppression, dust collection and if necessary personal protective equipment during the operation of the planer or of any attachment that may cause high levels of dust.

WARNING!



REMOVE PAINT BEFORE WELDING OR HEATING

Hazardous fumes/dust can be generated when paint is heated by welding, soldering or using a torch. Do all work outside or in a well ventilated area and dispose of paint and solvent properly. Remove paint before welding or heating.

When sanding or grinding paint, avoid breathing the dust. Wear an approved respirator. If you use solvent or paint stripper, remove stripper with soap and water before welding. Remove solvent or paint stripper containers and other flammable material from area. Allow fumes to disperse at least 15 minutes before welding or heating.

WARNING!



END OF LIFE DISPOSAL

At the completion of the useful life of the unit, drain all fluids and dismantle by separating the different materials (rubber, steel, plastic, etc.). Follow all federal, state and local regulations for recycling and disposal of the fluid and components.



OPERATING THE PLANER

- Block off work area from bystanders, livestock, etc.
- Operate only from the operator's station.
- Reduce speed when driving over rough terrain, on a slope, or turning, to avoid overturning the vehicle.
- An operator must not use drugs or alcohol, which can change his or her alertness or coordination. An operator taking prescription or over-the-counter drugs should seek medical advice on whether or not he or she can safely operate equipment.
- Before exiting the prime mover, lower the attachment to the ground, turn off the prime mover's engine, remove the key and apply the brakes.
- Be sure all doors, guards and shields are in their proper position and securely attached before operating the planer.

EQUIPMENT SAFETY PRECAUTIONS



TRANSPORTING THE PLANER

- Travel only with the attachment in a safe transport position to prevent uncontrolled movement. Drive slowly over rough ground and on slopes.
- When transporting on a trailer: Secure attachment at recommended tie down locations using tie down accessories that are capable of maintaining attachment stability.
- When driving on public roads use safety lights, reflectors, Slow Moving Vehicle signs etc., to prevent accidents. Check local government regulations that may affect you.
- Do not drive close to ditches, excavations, etc., cave in could result.
- Do not smoke when refueling the prime mover. Allow room in the fuel tank for expansion. Wipe up any spilled fuel. Secure cap tightly when done.



MAINTAINING THE PLANER

- Before performing maintenance, lower the attachment to the ground, turn off the engine, remove the key and apply the brakes.
- Never perform any work on the attachment unless you are authorized and qualified to do so. Always read the operator service manual's before any repair is made. After completing maintenance or repair, check for correct functioning of the attachment. If not functioning properly, always tag "DO NOT OPERATE" until all problems are corrected.
- Worn, damaged, or illegible safety decals must be replaced. New safety decals can be ordered from BRADCO.
- Never make hydraulic repairs while the system is under pressure. Serious personal injury or death could result.
- Never work under a raised attachment.

DECALS

DECAL PLACEMENT

GENERAL INFORMATION

The diagram on this page shows the location of the decals used on the BRADCO Cold Planers. The decals are identified by their part numbers, with reductions of the actual decals located on the following pages. Use this information to order replacements for lost or damaged decals. Be sure to read all decals before operating the attachment. They contain information you need to know for both safety and product longevity.

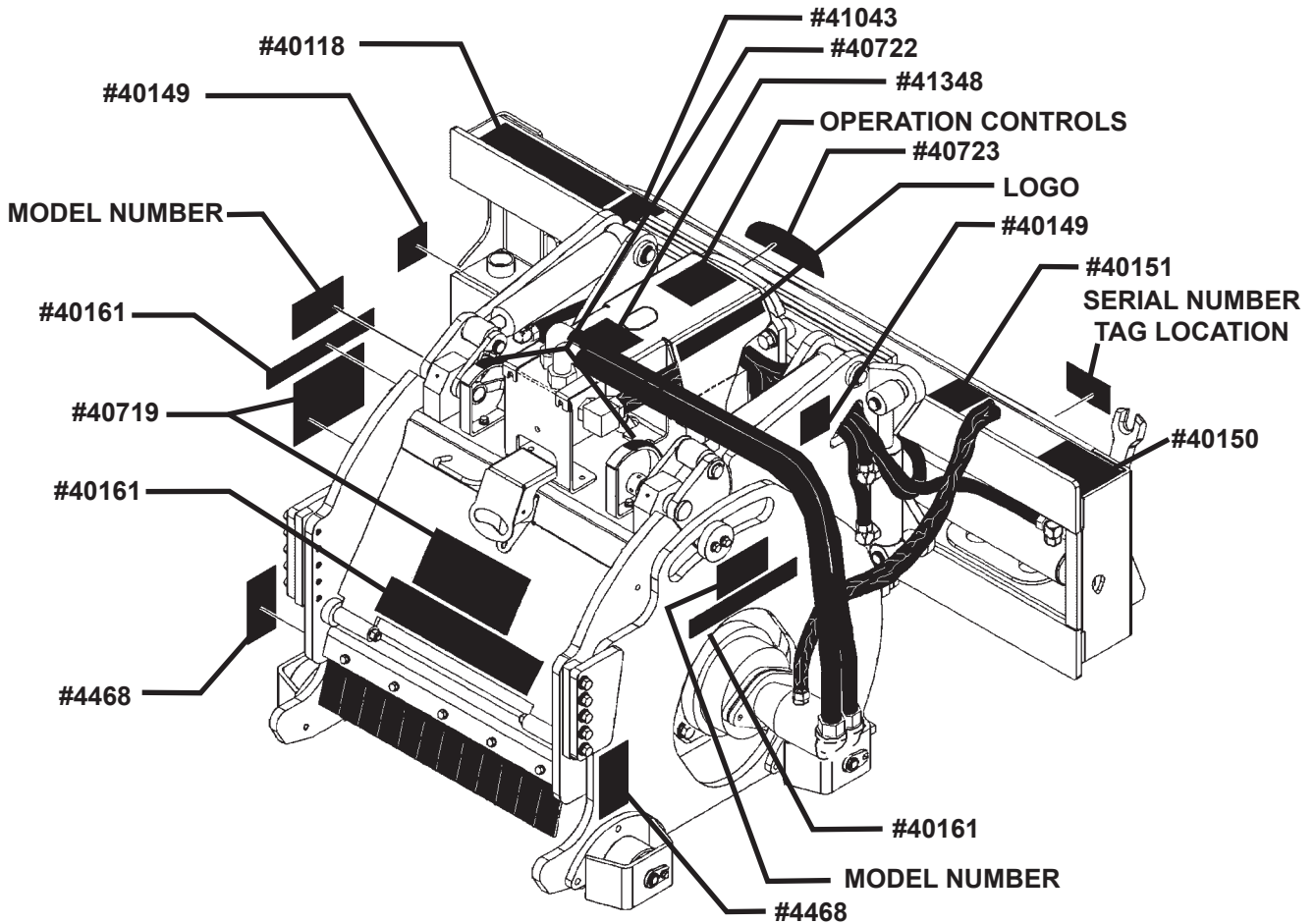

IMPORTANT: Keep all safety decals clean and legible. Replace all missing, illegible, or damaged safety decals. When replacing parts with safety decals attached, the safety decals must also be replaced.

REPLACING SAFETY DECALS: Clean the area of application with nonflammable solvent, then wash the same area with soap and water. Allow the surface to fully dry. Remove the backing from the safety decal, exposing the adhesive surface. Apply the safety decal to the position shown in the diagram above and smooth out any bubbles.

DECALS



DANGER! PINCH POINTS
PART #40149



WARNING! HIGH PRESSURE FLUID
PART #40151



WARNING!
PART #4468

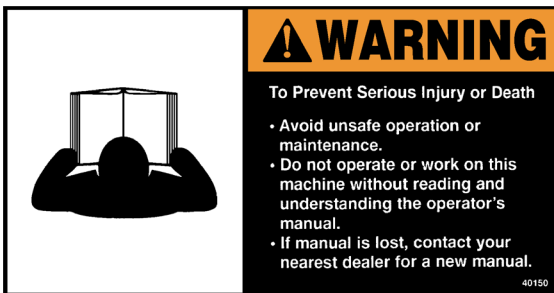

WARNING! READ MANUAL
PART #40150



STAND CLEAR
PART #40161



DANGER! FLYING DEBRIS
PART #40719 (LARGE)
PART #40855 (SMALL)



WARNING! HAZARDOUS DUST
PART #41043

DECALS

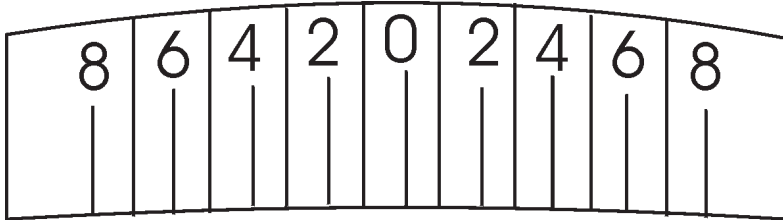

ANGLE INDICATOR
PART #40723

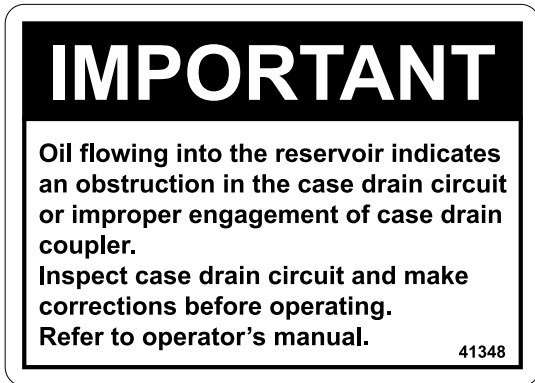

IMPORTANT! OIL RESEVOIR
PART #41348

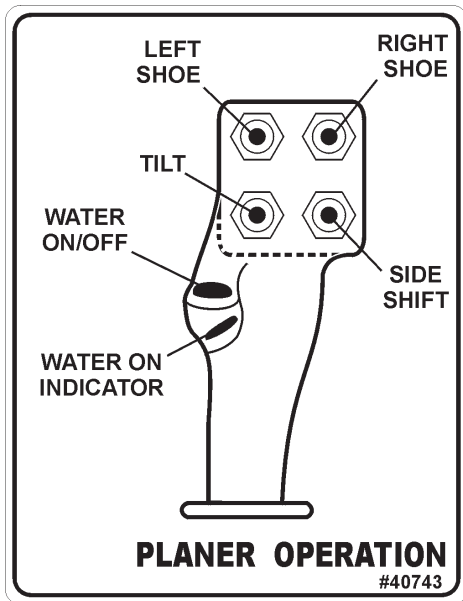

*OPERATION CONTROLS
PART #40743

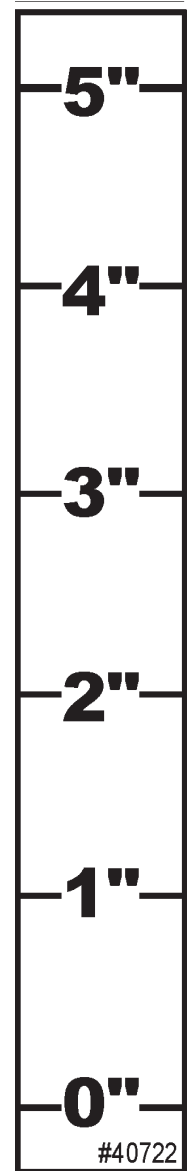

DEPTH INDICATOR
PART #40722

NOTE: CONTACT YOUR LOCAL DEALER FOR MODEL NUMBER AND LOGO DECALS.

PRE-OPERATION

SKID STEER

The BRADCO 16", 18", 24", 30" and 40" planers are designed for use on high flow skid steers. Cold planer and skid steer compatibility is determined by the recommended lifting capacity and hydraulic output of your skid steer.

WARNING! Do NOT attach or operate any attachment that exceeds the recommended lifting capacity of your skid steer.



Skid steers MUST be equipped with optional high flow, auxiliary boom hydraulics, case drain and a multi-function electric control kit to run the cold planer.

WARNING! EXPOSURE TO RESPIRABLE CRYSTALLINE SILICA DUST ALONG WITH OTHER HAZARDOUS DUSTS MAY CAUSE SERIOUS OR FATAL RESPIRATORY DISEASE.



This attachment is designed to plane (mill) rock, concrete and asphalt, causing high levels of dust. It is recommended to use dust suppression, dust collection and if necessary personal protective equipment during the operation of the planer or of any attachment that may cause high levels of dust!

IMPORTANT

Concrete and masonry products contain silica sand. Quartz, which is a form of silica and the most common mineral in the earth's crust, is associated with many types of rock.

Some activities that silica dust may be present in the air include demolition, sweeping, loading, sawing, hammering, drilling or planing of rock, concrete or masonry.

It is recommended to use dust suppression (such as water), dust collection (such as a vacuum) along with personal protective equipment if necessary during the operation of any attachment that may cause high levels of silica dust.

OPTIONS

PLANING OPTIONS	Concrete Picks.....	Contact Dealer
	2.5" (Slot Cutter) Drum.....	#100642
	4.0" (Slot Cutter) Drum.....	#100643
	6.0" (Slot Cutter) Drum.....	#100644
MOTOR OPTIONS	22 GPM to 28 GPM (2.0 CU. IN. BLUE).....	#17776
	29 GPM to 35 GPM (2.5 CU. IN. BLACK).....	#17777
	36 GPM to 44 GPM (3.0 CU. IN. RED).....	#17778

NOTE: 36 GPM to 44 GPM motor is required on the 40" Cold Planers.

PRE-OPERATION

HIGH FLOW COLD PLANERS

NOMENCLATURE

Throughout this manual, reference is made to various attachment components. The purpose of this section is to acquaint you with the various names of these components. This knowledge will be helpful when reading through the manual or when ordering service parts.

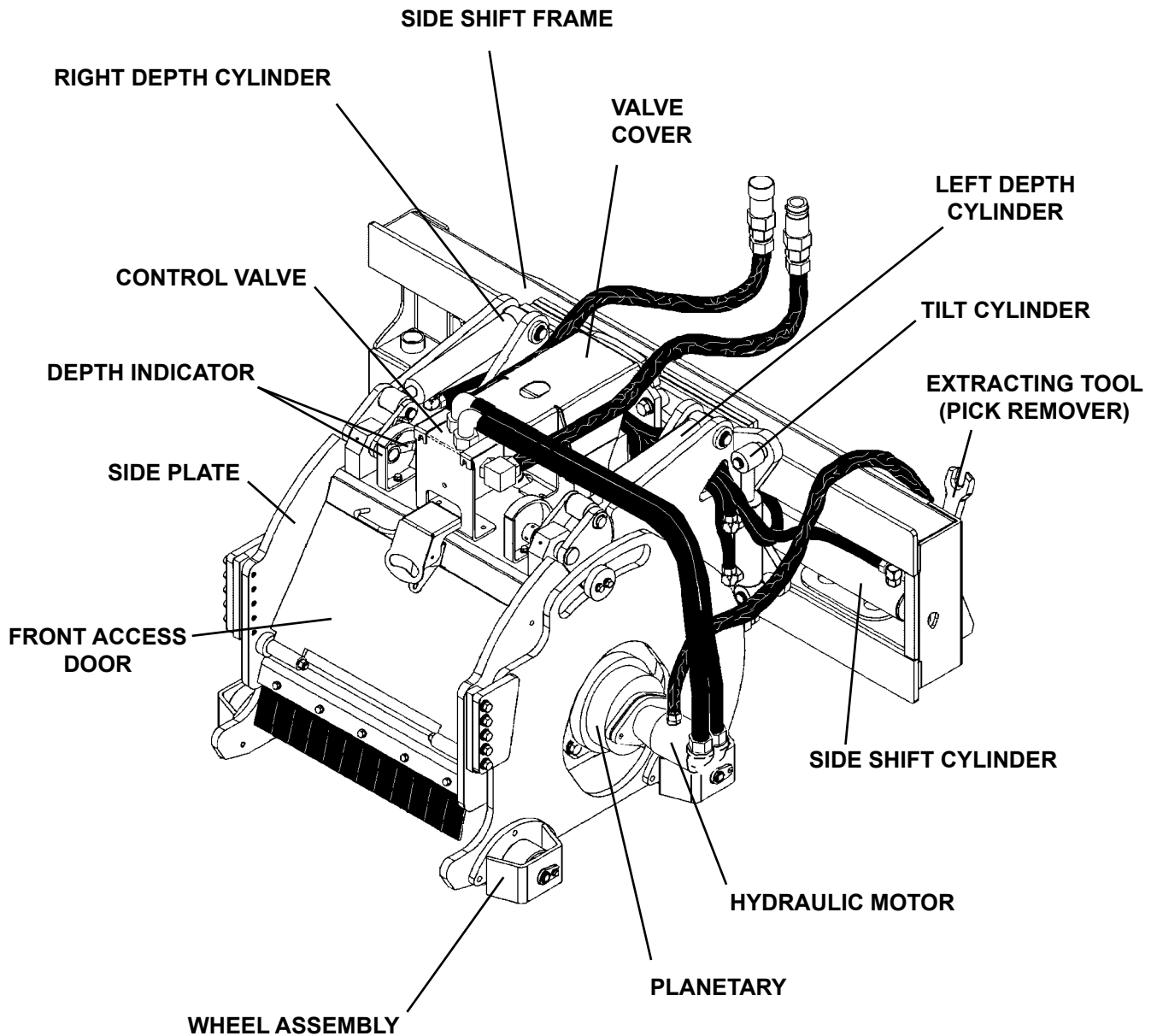

INSTALLATION

GENERAL INFORMATION

The following instructions will help you to mount your planer onto your skid steer loader. The planer uses the quick-attach system for ease of installation. Therefore, if you know how to attach your loader bucket, attaching the cold planer should prove no problem.

Remember to read all safety warnings, decals and operating instructions before operating the attachment. If there is any portion of this manual that you do not understand, contact your dealer.

WARNING! THE 16", 18", 24", 30" AND 40" PLANERS ARE DESIGNED FOR USE ON HIGH FLOW HYDRAULIC SYSTEMS. DO NOT ATTACH OR OPERATE ANY ATTACHMENT THAT EXCEEDS THE RECOMMENDED LIFTING CAPACITY OF YOUR SKID STEER.



INSTALLATION INSTRUCTIONS

1. Remove the shipping banding from around the planer and skid.
2. Remove any attachments from the front of the loader.
3. Following all standard safety practices and the instructions for installing an attachment in your skid steer operator's manual, install the planer onto your skid steer.

NOTE: It is important to make sure the locking mechanism on your quick attach is engaged, therefore locking the attachment onto the skid steer.

4. Lower the unit to the ground and remove the key.
5. Relieve any pressure from the auxiliary hydraulic system. After making sure that there is not any foreign matter on the hydraulic couplers connect the case drain coupler to the case drain on your skid steer loader. NOTE: The case drain line must be connected first, then the power and return hoses. When disconnecting the hoses, it is recommended to disconnect the case drain line last.
6. Connect the power and return couplers to the high flow auxiliary hydraulic system of your skid steer loader. Route the hose in such a fashion as to avoid pinching or chafing.

CAUTION! BE SURE CASE DRAIN COUPLER IS COMPLETELY ENGAGED. IMMEDIATE HYDRAULIC MOTOR SEAL FAILURE AND PLANETARY DAMAGE WILL OCCUR IF CASE DRAIN IS NOT SUCCESSFULLY CONNECTED.



7. Connect the electrical wire harness from the cold planer to the auxiliary electrical connector on the front of the skid steer (if so equipped). If your skid steer is not equipped with an electrical connector and you are using the BRADCO control handle, connect the wiring harness to the control handle and place the control handle inside of the skid steer operator's station.

WARNING! Do not operate the cold planer from outside of the skid steer operator's station.



INSTALLATION

8. Following all standard safety practices, start the skid steer and run all cylinders through their full cycle to purge any air from the system. Check that all controls function in accordance with the operating control decal.
9. All planers are equipped with a water nozzle kit to adapt them to your existing water line. Install the female coupler supplied to your existing water line coming from the water tank on the skid steer. Connect the female coupler to the male coupler on the planer water nozzle kit. NOTE: There is an optional cab mounted water kit available through your local dealer.

Your planer is now installed and ready for operation.

DISCONNECT INSTRUCTIONS

1. Center the planer on the sideshift frame.
2. Adjust depth and tilt setting to "0".
3. Set cold planer on a firm level surface.
4. Following Safety Shut Down Procedures; stop the engine and set the parking brake. Relieve any pressure in the hydraulic lines.
5. Disconnect the power and return hoses from the auxiliary hydraulics. Disconnect the case drain line. NOTE: It is recommended to disconnect the case drain line last.
6. Disconnect the electrical wire harness from the auxiliary electrical connector or the BRADCO control handle and after turning the ball valve to the shut off position disconnect the water line at the couplers.
7. Following all standard safety practices and the instructions for disconnecting an attachment in your skid steer operator's manual, disconnect the planer from your skid steer allowing the mounting bracket to lower toward the ground as the skid steer is disengaged.
8. Connect the hydraulic couplers on the attachment together to prevent contaminants from entering the hydraulic system.

OPERATING INSTRUCTIONS

CONTROLS

GENERAL INFORMATION

The cold planers are operated with either a Paladin control handle or an in-cab multi-function control handle.

PALADIN CONTROL HANDLE #19215

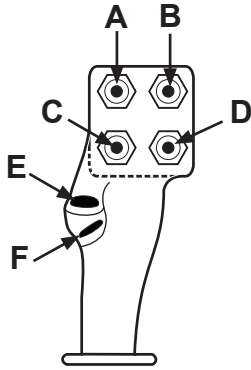

- A = Left Depth
- B = Right Depth
- C = Tilt
- D = Side Shift
- E = Water ON/OFF
- F = Indicator Light

CASE CONTROL HANDLES #116745

SELECT FUNCTION AND FLOW DIRECTION

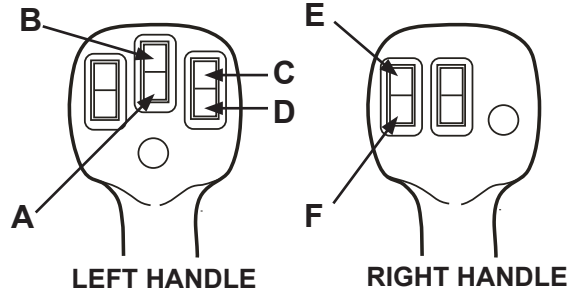

- | | |
|-----------------|------------------|
| A = Left Depth | D = Side Shift |
| B = Right Depth | E = Forward Flow |
| C = Tilt | F = Reverse Flow |

NEW HOLLAND CONTROL HANDLES #116745

SELECT FUNCTION AND FLOW DIRECTION

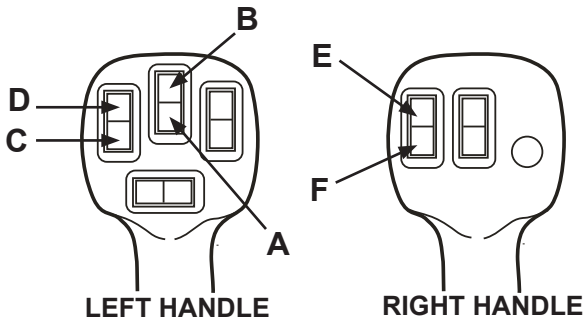

- | | |
|-----------------|------------------|
| A = Left Depth | D = Side Shift |
| B = Right Depth | E = Forward Flow |
| C = Tilt | F = Reverse Flow |

JCB/VOLVO CONTROL HANDLES #118470

SELECT FUNCTION AND FLOW DIRECTION

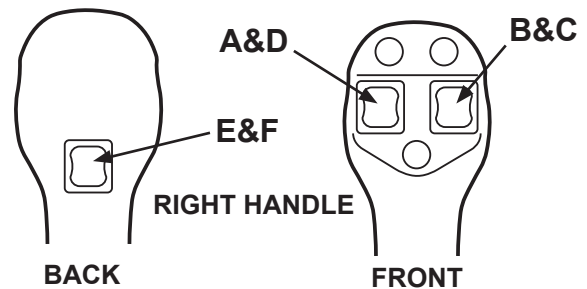

- | | |
|-----------------|------------------|
| A = Left Depth | D = Side Shift |
| B = Right Depth | E = Forward Flow |
| C = Tilt | F = Reverse Flow |

CAT "D" SERIES CONTROL HANDLE #120262

SELECT FUNCTION AND FLOW DIRECTION

#120262

SWITCH PANEL ON CAB PILLAR

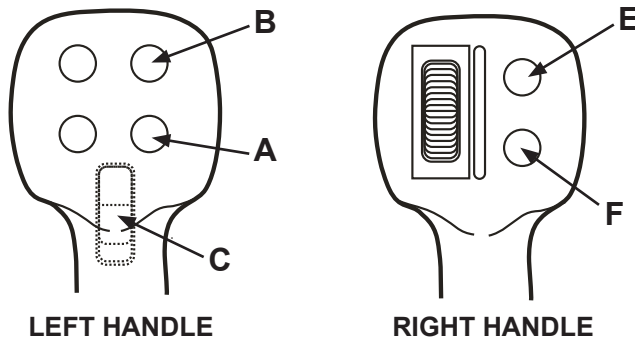
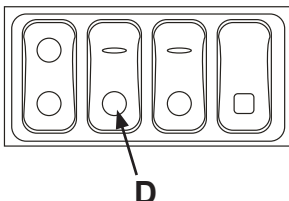

- A = Left Depth
- B = Right Depth
- C = Tilt
- D = Side Shift
- E = Forward Flow
- F = Reverse Flow

OPERATING INSTRUCTIONS

CONTROLS

TAKEUCHI CONTROL HANDLE

#120337

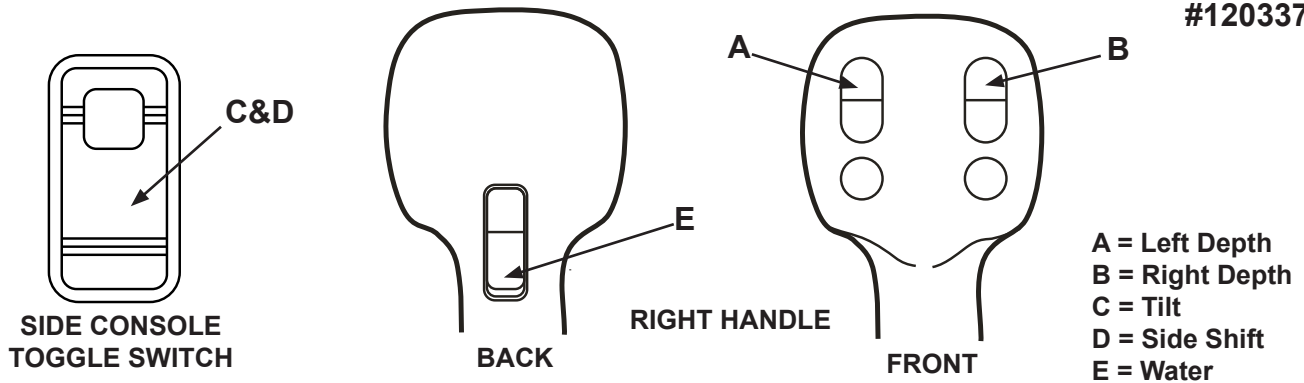

KUBOTA SSV CONTROL HANDLE

SELECT FUNCTION AND FLOW DIRECTION

#116745

#114874

ISO CONTROLS

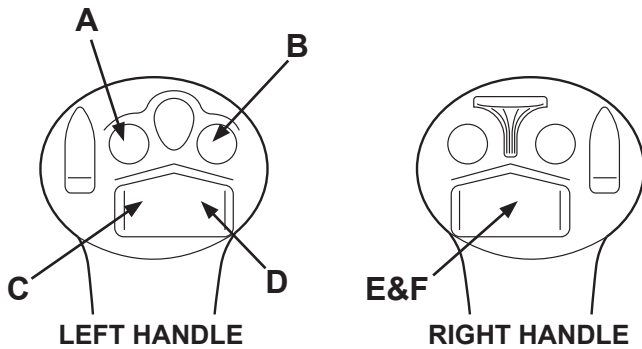

STANDARD CONTROLS

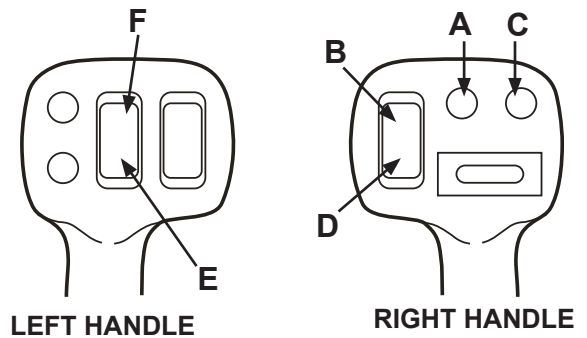

KUBOTA SVL CONTROL HANDLE

SELECT FUNCTION AND FLOW DIRECTION

#118470

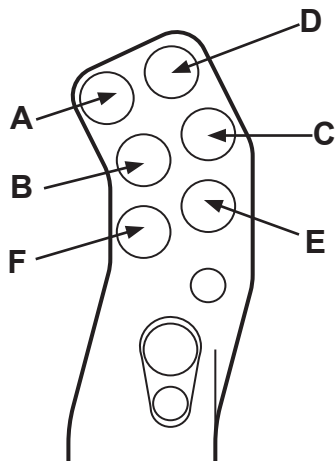

JOHN DEERE CONTROL HANDLE

SELECT FUNCTION AND FLOW DIRECTION

#120262

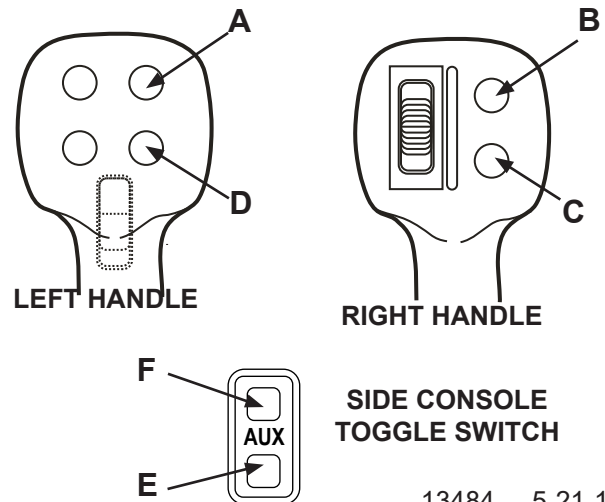

13484 5-21-19

OPERATING INSTRUCTIONS

INTENDED USE:

This unit is designed to plane / mill horizontal surfaces consisting of rock, concrete and asphalt. Use in any other way is considered contrary to the intended use.

GENERAL INFORMATION

The BRADCO planer attaches to the toolbar/quick-attach mechanism of your skid steer loader. Due to this arrangement, thorough knowledge of the skid steer controls is necessary for machine operation. Read and understand your skid steer operator's manual for information regarding skid steer operation before attempting to use the planer.

Check the surface to be planed. The standard all purpose picks can be used to mill both asphalt and concrete. There are optional concrete picks that are recommended if the planer is to be used extensively for concrete. These picks do not perform as well when milling asphalt, especially in warmer weather.

Review the job at hand and determine the required depth and tilt of the cut and also the side shift position of the planer. Best performance is obtained when the cold planer is in the center position. Side shift should be used when visibility is a determining factor such as milling around manholes or when milling next to an obstacle such as a building. **NOTE: Although the wheel assemblies are standard, they may be removed when distance is a factor such as milling next to an obstacle or building.**

OPERATING INSTRUCTIONS

NOTE: It is recommended before milling, especially in cold weather, that the skid steer oil is warmed. Running the loader for approximately 15 minutes before operation will help ensure proper oil flow to the planer.

1. Clear area of all bystanders.
2. Lift the planer until the drum is off the ground and start planer rotation. (Teeth at the bottom of the drum must be moving in the same forward direction that the planer travels.)

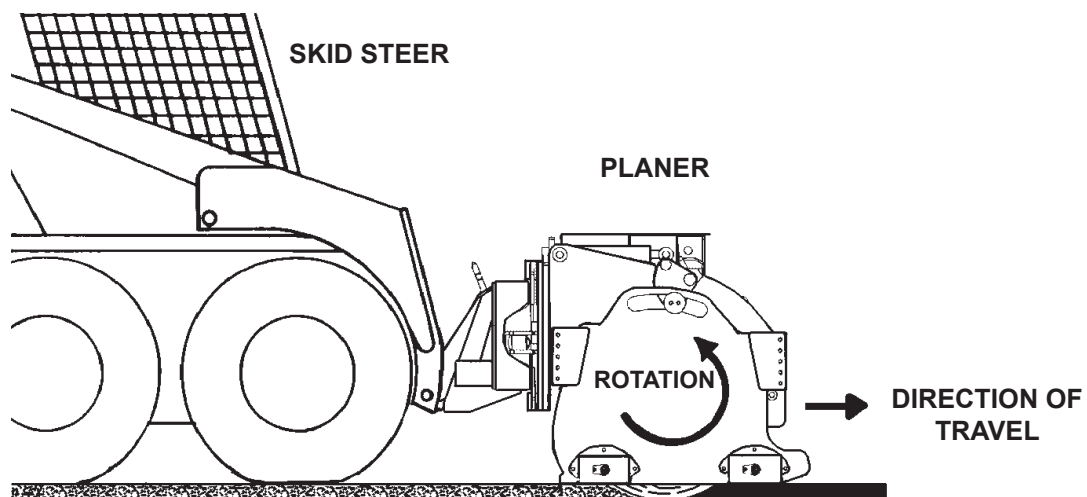

NOTE: Mill only when the skid steer is traveling forward. Do not operate when traveling in reverse.

OPERATING INSTRUCTIONS

NOTE: Hydraulic cylinders tilt the planer, adjust the depth of both the left and right side of the planer individually, and also shift the planer to the left or right.

3. Increase engine RPM and with the drum turning you can make any necessary adjustments to the side shift. Do not side shift the cold planer during milling operation. Once the desired side shift position has been achieved you are ready to begin. The drum will not cut in a side to side motion.

IMPORTANT: The drum MUST be turning to make hydraulic adjustment to the planer cylinders before milling.

4. Position the planer at the desired starting point. Set the left and right depth gauge to the desired depth mark on the planer. Maximum depth of each cut is determined by the type of material, the horsepower of the skid steer being used and the size of the planer. It is recommended for maximum performance that you start at approximately .75" to 1" in concrete and 1.50" to 2" in asphalt.
5. With the engine at full RPM and the planer rolled back, lower the loader arms completely down and slowly roll out the planer until the weight of the planer is resting on the rear wheel assemblies. Continue to exert down pressure by rolling the loader forward until the front wheels of the planer are on the ground and the front wheels of the skid steer are raised approximately 2-3 inches off the planing surface to assure sufficient pressure for stable operation.

NOTE: It is recommended to try a sample cut until the desired depth is achieved.

6. Slowly advance forward.

IMPORTANT: When starting the milling operation, keep an eye on the reservoir. If oil is entering the reservoir, there is something wrong. Shut down and evaluate. See Maintenance & Service.

NOTE: If drum stalls you have been traveling too fast or cutting too deep. Back out of the cut until the drum restarts (make necessary adjustments) and continue operation.

NOTE: If the drum tends to ride up out of the cut, decrease travel speed, be sure the planer is level (front to back) and exert down pressure until the planer is riding on the wheel assemblies. For optimal cutting and reduced vibration, maintain down pressure on the planer with all four planer wheels on the ground when cutting.

NOTE: Avoid side to side movement while planing as this may cause excessive drum wear or planetary failure.

7. When you have reached the end of the pass, stop the skid steer and raise the planer out of the cut. Reposition skid steer for the next cut and repeat steps 4, 5 & 6. If you are not starting a new cut, raise the planer and retract the drum into the planer housing using the depth control cylinders. Do not transport the planer with drum turning.
8. Be sure to continue to monitor the reservoir while milling. If reservoir begin to fill, shut down and evaluate. See Maintenance & Service.

9835B 11-31-17-3

OPERATING INSTRUCTIONS

CAUTION!



Periodic observation must be made of the transmission oil temperature indicator when planing with high flow hydraulic systems. Depending on the ambient temperature and the duty cycle of the machine, hydraulic oil may overheat. If indicator comes on, shut off the cold planer and allow the skid-steer to idle until the temperature falls below 160° Fahrenheit. If the system continues running hot it may be necessary to clean any debris from the oil cooler and radiator. Check engine air filter and also the hydraulic oil level. Continuous or excessive overheating may cause machine damage.

SPECIAL APPLICATIONS

LARGE AREA

BRADCO'S independent depth control design allows for continuous milling. Instead of planing pass 1, 3, 5 and then going back and resetting the planer for passes 2 and 4, the BRADCO planer allows for individual depth control from the operator's seat to enhance performance and continually mill large areas.

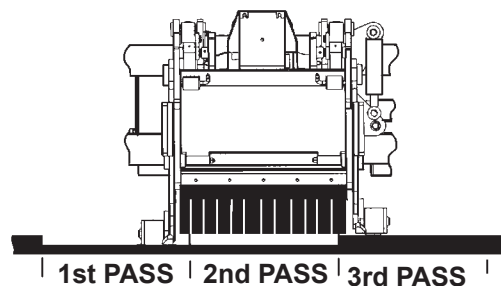
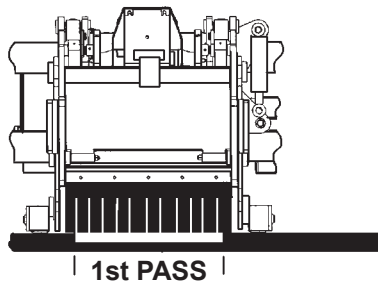

MILLING AROUND MANHOLES

For best visibility when milling around manholes it is recommended that the planer be shifted to the right. The planer is not designed to mill around tight corners, therefore it is recommended that four to six passes be made on each side of the manhole. NOTE: The more passes the less amount of manual clean-up required.

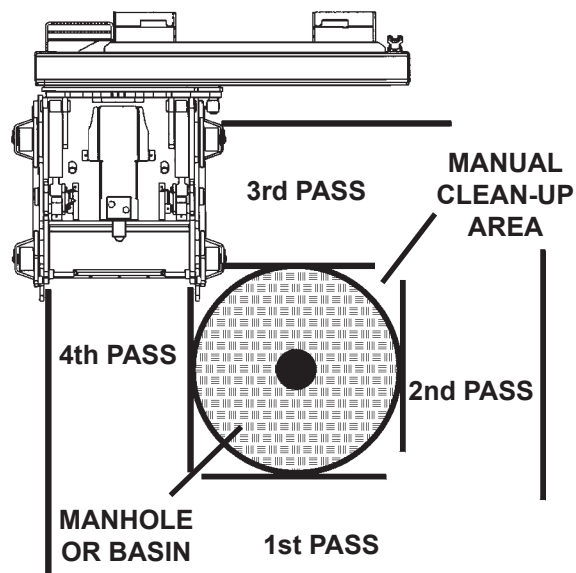

OPERATING INSTRUCTIONS

DEEP CUTS

To achieve a deep cut the width of the drum, make the first cut at the recommended depth for the material being milled and then reposition the planer at the beginning of the pass and reset for double the recommended depth. Example: Make the first cut with the depth controls set at 2" and then set the depth control at 4" for the second pass and so on and so forth until the desired depth is obtained.

To achieve a 6" cut of a large area it is recommended to cut the entire area at the recommended depth and then clear the spoil from the area before making the second cut. Removing the spoil between cuts will enhance the productivity of the planer and maintain an even cut.

If trying to achieve a critical cutting depth it is recommended that the spoil from one cut be cleared away before making another pass. This will eliminate the possibility of the planer riding on and off the spoil and creating an uneven surface.

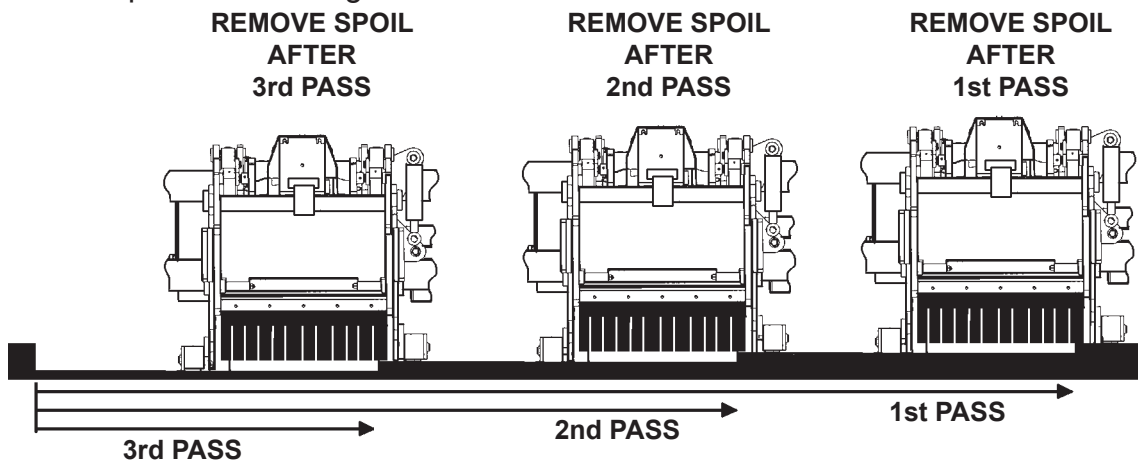

MILLING TAPER CUTS

When adding to or joining new paved surfaces to existing paving, a taper cut may be required at the interacting joints so the new paving would appear seamless. See the chart below for the angle of cut per size of cold planer.

Example: To achieve a taper cut from 0" to 4" over a 4' distance with a 24" wide cold planer it is recommended that you set one side of the planer at 2" and the other at 4" and the tilt set at 4° for the first pass. Then make a second pass with both sides of the planer set at 0" and the tilt still at 4°.

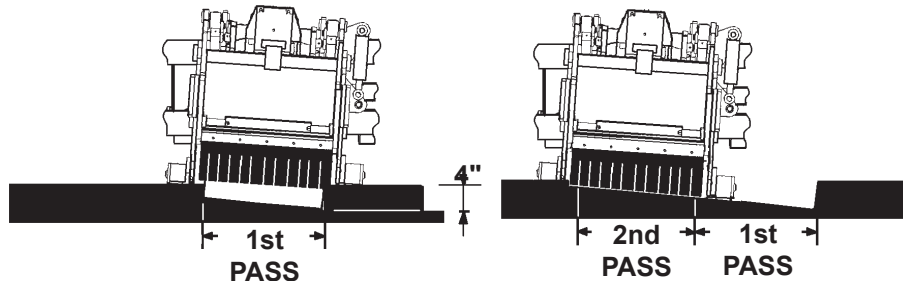

MODEL	ANGLE OF CUT PER OFFSET			
	1"	2"	3"	4"
16" COLD PLANER	3°	6°	8°	NA
18" COLD PLANER	3°	6°	8°	NA
24" COLD PLANER	2°	4°	6°	NA
30" COLD PLANER	2°	4°	5°	7°
40" COLD PLANER	1.5°	3°	4°	6°

9396 7-27-07-3

OPERATING INSTRUCTIONS

STORAGE

- Clean the unit thoroughly, removing all mud, dirt, and grease.
- Inspect for visible signs of wear, breakage, or damage. Order any parts required and make the necessary repairs to avoid delays upon removal from storage.
- Tighten loose nuts, capscrews and hydraulic connections.
- Coat exposed portions of the cylinder rods with grease.
- Lubricate grease fittings.
- Seal hydraulic system from contaminants and secure all hydraulic hoses off the ground to help prevent damage.
- Replace decals that are damaged or in unreadable condition.
- Store unit in a dry and protected place. Leaving the unit outside will materially shorten its life.

Additional Precautions for Long Term Storage:

- Touch up all unpainted surfaces with paint to prevent rust.

REMOVAL FROM STORAGE

- Remove cover.
- Wash unit and replace any damaged and/or missing parts.
- Lubricate grease fittings.
- Check hydraulic hoses for damage and replace as necessary.

LIFT POINTS

Lifting points are identified by lifting decals where required. Lifting at other points is unsafe and can damage attachment. Do not attach lifting accessories around cylinders or in any way that may damage hoses or hydraulic components. See Diagram

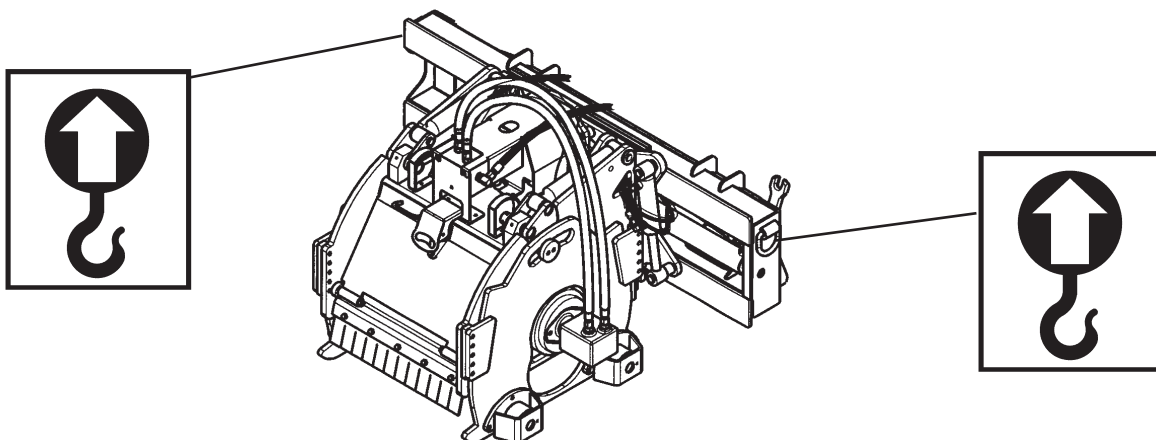

- Attach lifting accessories to unit at recommended lifting points.
- Bring lifting accessories together to a central lifting point.
- Lift gradually, maintaining the equilibrium of the unit.

OPERATING INSTRUCTIONS

WARNING! Use lifting accessories (chains, slings, ropes, shackles and etc.) that are capable of supporting the size and weight of your attachment. Secure all lifting accessories in such a way to prevent unintended disengagement. Failure to do so could result in the attachment falling and causing serious personal injury or death.



TIE DOWN POINTS

Tie down points are identified by tie down decals where required. Securing to trailer at other points is unsafe and can damage attachment. Do not attach tie down accessories around cylinders or in any way that may damage hoses or hydraulic components. See Diagram

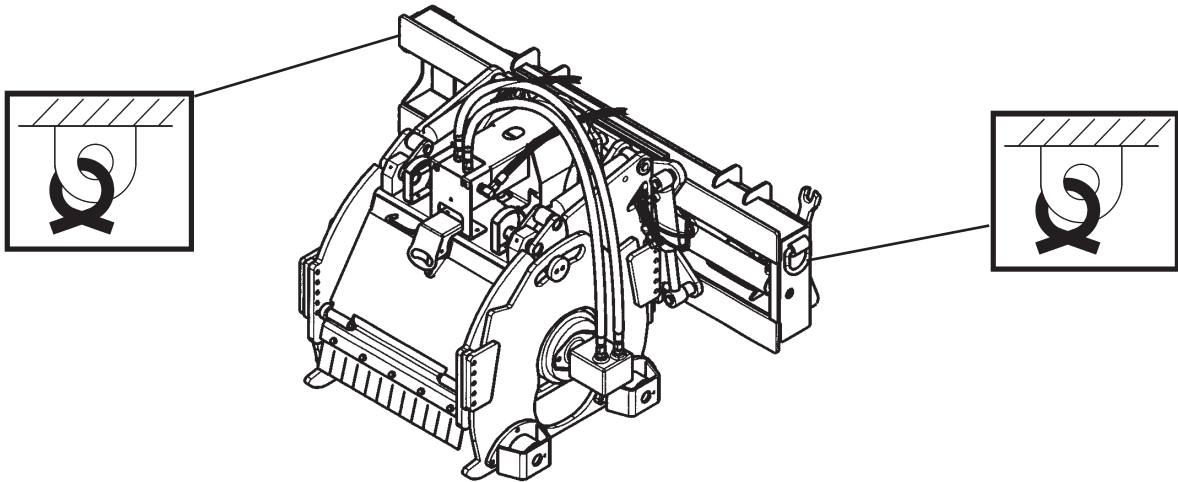

- Attach tie down accessories to unit as recommended.
- Check unit stability before transporting.

WARNING! Verify that all tie down accessories (chains, slings, ropes, shackles and etc.) are capable of maintaining attachment stability during transporting and are attached in such a way to prevent unintended disengagement or shifting of the unit. Failure to do so could result in serious personal injury or death.



TRANSPORTING

Follow all local government regulations that may apply along with recommended tie down points and any equipment safety precautions at the front of this handbook when transporting your attachment.

MAINTENANCE & SERVICE

LUBRICATION

GENERAL INFORMATION

Economical and efficient operation of any machine is dependent upon regular and proper lubrication of all moving parts with a quality lubricant. Neglect leads to reduced efficiency, wear, breakdown and needless replacement of parts.

All parts provided with grease fittings should be lubricated as indicated. If any grease fittings are missing, replace them immediately. Clean all fittings thoroughly before using the grease gun.

IMPORTANT: Avoid excessive greasing. Dirt collects on exposed grease and greatly increases wear. After greasing, wipe off excessive grease from fittings.

LUBRICATION SYMBOLS

The following symbols are used on the lubrication diagram below. It is reproduced here with its meaning for your convenience.



Lubricate daily or every 8 hours of operation, whichever comes last, with SAE Multi-Purpose Lubricant or equivalent SAE Multi-Purpose type grease.



Lubricate weekly or every 40 hours of operation, whichever comes last, with SAE Multi-Purpose Lubricant or equivalent SAE Multi-Purpose type grease.



CAUTION! SHUT OFF ENGINE BEFORE LUBRICATING EQUIPMENT.

The planer planetary is a sealed unit. If there is any sign of oil leaks please contact your nearest BRADCO dealer before carrying out any repairs, as there can be other causes for seal leaks. The planetary uses the Gear Oil (Castrol SP 320) for lubrication of gears and bearings. The Digga planetary uses approximately 2 quarts of gear oil while the Auburn planetary uses approximately 1 quart of gear oil.

The Digga planetary gear oil should be drained and replaced after the first 50 hours of use. Thereafter every 12 months or 2500 hours - whichever comes first. The Auburn planetary gear oil should be drained and replaced after the first 50 hours of use. Thereafter every 12 months or 1000 hours - whichever comes first.

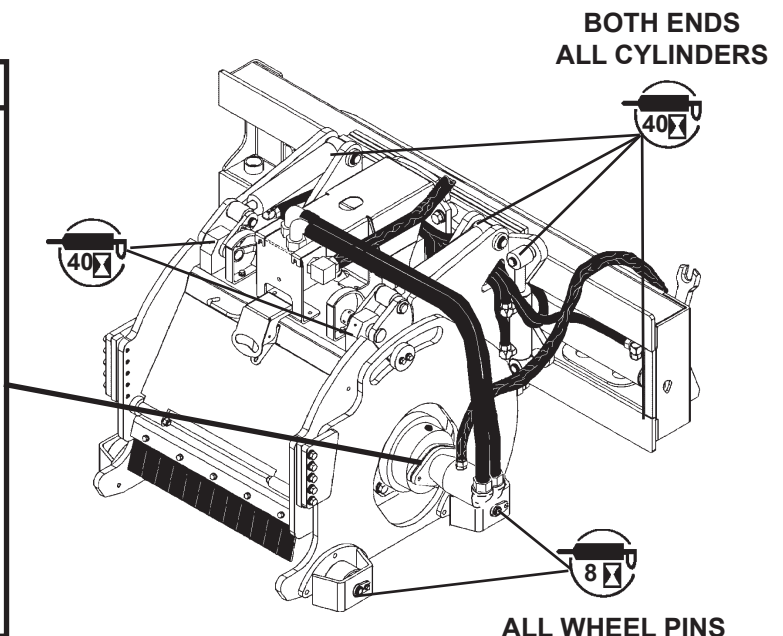
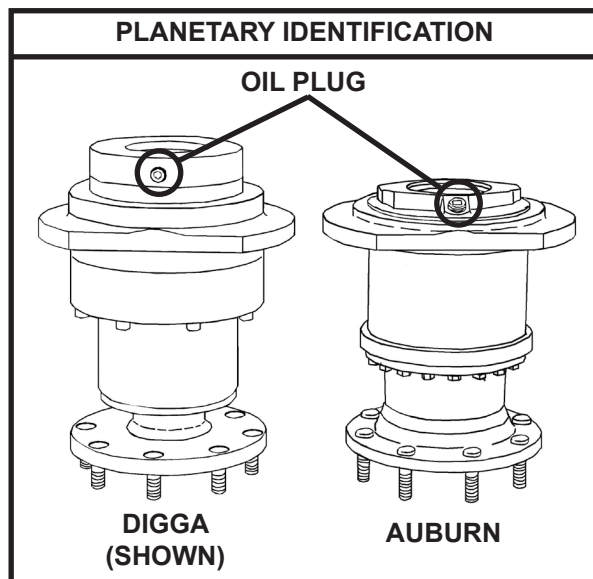

9836 5-30-13-3

MAINTENANCE & SERVICE

GENERAL INFORMATION

Regular maintenance is the key to long equipment life and safe operation. Maintenance requirements have been reduced to an absolute minimum. However it is very important that these maintenance functions be performed as described below.

WARNING! Never do any maintenance to the planer while it is running. Exercise the **MANDATORY SAFETY SHUTDOWN PROCEDURE BEFORE** working on or around the planer.



Procedure	Daily	Every 40 Hours	After First 50 Hours	Every 1000 Hours (Yearly)	Every 2500 Hours (Yearly)
Case Drain Coupler - Check for complete engagement of coupler.	✓				
Check for kinked or pinched hoses. Reroute as required.	✓				
Hydraulic Oil - Check prime mover hydraulic system for adequate oil levels.	✓				
Hardware - Check for tightness (see Bolt Torque Specifications)	✓				
Hardware - Replace any missing or damaged bolts or nuts with approved replacement parts.	✓				
Hydraulic System - Check for leaks and tighten as necessary. Check for damage and replace as needed.	✓				
Decals - Check for missing or damaged safety decals and replace as necessary.	✓				
Check picks for freedom of rotation, flat spots and wear. Replace worn or missing picks or any picks that are not moving freely or have flat spots.	✓				
Inspect attachment for any worn parts or cracked welds. Repair as required.	✓				
Lubricate grease fittings on wheel pivot pins.	✓				
Lubricate grease fitting on idler bearing. (Right side 40" Planer ONLY)	✓				
Lubricate grease fittings on cylinder ends and front of planer.		✓			
Change gear oil in Digga planetary.			✓		✓
Change gear oil in Auburn planetary.			✓	✓	

MAINTENANCE & SERVICE

IMPORTANT: When replacing parts use only factory approved replacement parts. Manufacturer will not claim responsibility for use of unapproved parts or accessories and/or other damages as a result of their use.

PICK REPLACEMENT

Picks should be replaced if you are changing to a different application pick, they are broken, worn, flat spot or are seized in the pick holder and do not rotate freely.

WARNING! Always wear safety glasses with side shields when striking metal. Failure to heed could result in serious injury to the eyes or other parts of the body.



Do all pick maintenance through access door.

DO NOT attempt to check the picks with the planer in a raised position without first blocking the planer. Before exercising the **MANDATORY SAFETY SHUT-DOWN PROCEDURE** find an elevated surface to set the planer on or have a second person block the planer in place before shutting down the machine.

1. Open front access door.
2. Rotate the drum until the pick to be removed is conveniently accessible.
3. Hold the extracting tool (pick puller) in one hand and place the jaws in the groove of the pick, with the offset handle pointing away from the pick holder.
4. Using a lead hammer or rubber-headed mallet, hit the raised pad on the tool until the pick starts to move. Continue tapping until the pick is removed.
5. Insert the new pick into the jaws of the extracting tool (pick puller) so that the raised pad of the tool is pointing in the same direction as the pick point.
6. Position the new pick in the pick holder on the drum and with a lead hammer or rubber-headed mallet, hit the raised pad of the tool to start the pick into the pick holder. (Clean out any foreign material from the pick holder before installing the new pick.)
7. Once the pick is started into the pick holder strike the tool pad one strong blow to pop the pick into the holder.

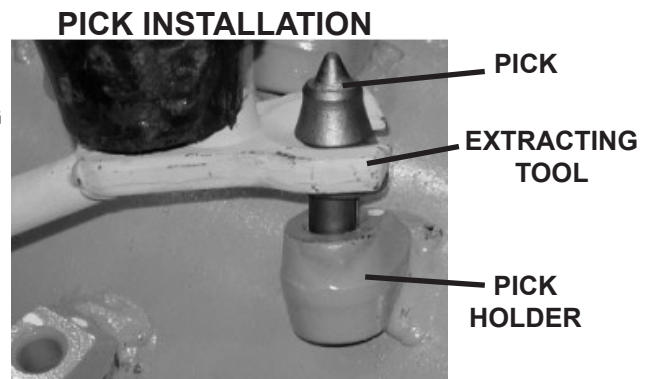
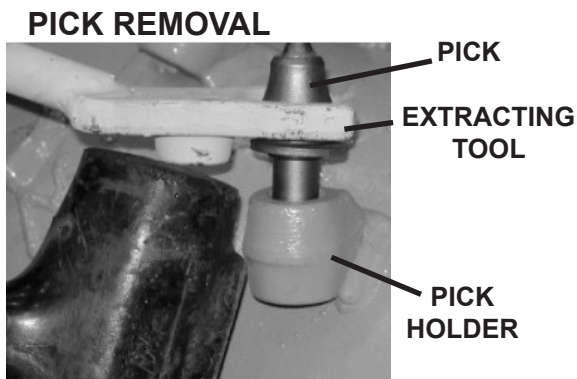

The pick is properly seated when its shoulder is against the face of the pick holder. Check to be sure the pick rotates freely.

9399 7-27-07-2

MAINTENANCE & SERVICE

CHANGING THE DRUM

Due to the weight of the unit, place the planer in a convenient location with a hoist available for lifting the planer off the drum.

1. Remove the right side plate by first removing the two bolts in the retainer and then loosen the ten .50" bolts on the clamp plates. Slide the right side plate off.

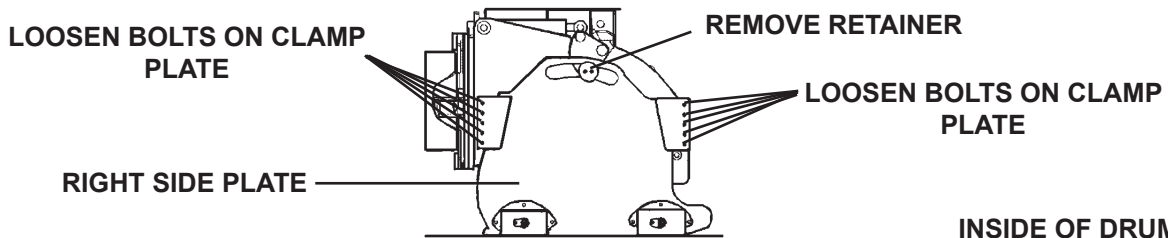

2. Remove the eight M16 hex nuts securing the drum to the planetary.
3. Using a pry bar, pry the drum off of the planetary and slide out until the drum clears the planetary. lift the planer off of the drum.
4. Install the new drum by positioning it over the studs on the planetary and installing the existing M16 hex nuts using Locktite 271 (Red) and torquing to 155 ft. lbs.
5. Reinstall the right side plate.

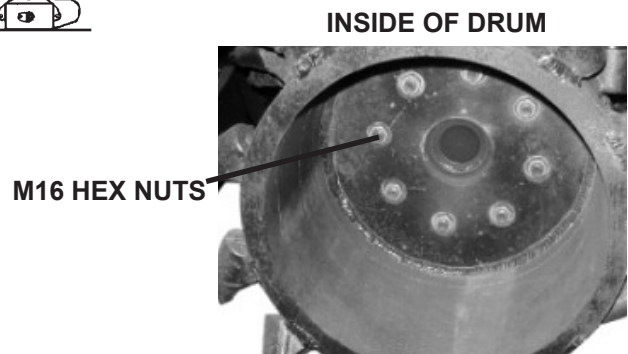

INSIDE OF DRUM

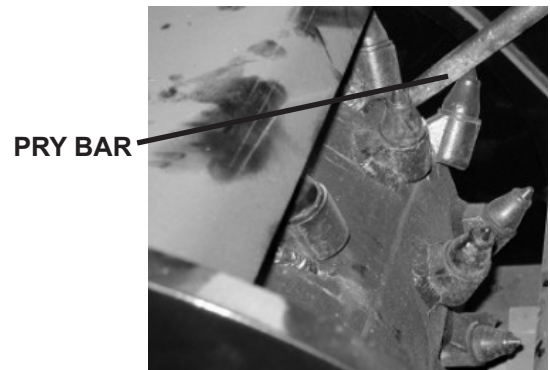

PRY DRUM OFF OF PLANETARY

CHANGING THE PLANETARY

To gain access to the planetary the drum must first be removed. Follow the above procedure for removing the drum.

1. Tag and disconnect the power and return hoses along with the case drain hose from the hydraulic motor and plug the motor ports to prevent contaminants from entering the hydraulic system.
2. Remove the .62" bolts securing the planetary to the planer and remove the planetary.

MAINTENANCE & SERVICE

3. Check to be sure the new planetary is filled with oil. If not, fill with Castrol SP 320 gear oil. (Digga Planetary - 2 quarts and Auburn Planetary - 1 quart. Auburn planetary should be half full when mounted level horizontally.) Do not overfill.
4. Remove the hydraulic motor from the planetary. Scrape any silicone from the hydraulic motor and apply new RV 10 silicone to the motor to seal the connection between the motor and the planetary. Bolt the hydraulic motor onto the new planetary using the existing hardware.

**TAG AND REMOVE
HYDRAULIC HOSES
FROM MOTOR**

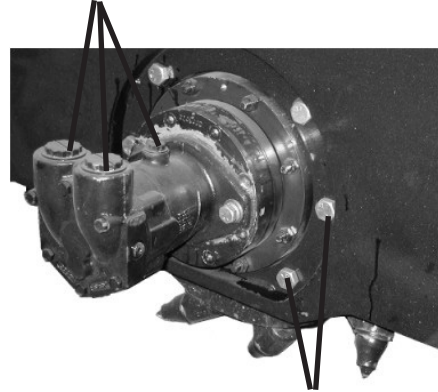

**REMOVE PLANETARY FROM PLANER BY
UNBOLTING .62" X 2.50" CAPSCREWS**

5. Position the new planetary into the planer housing and reinstall the .62" capscrews, flat washers and lock nuts. Check to ensure that the hydraulic motor is in the correct position with the ports turned up. Torque to specification
6. Reinstall the drum as described in "CHANGING THE DRUM".
7. Re-connect the hydraulic hoses and fittings to the motor.

CHANGING HYDRAULIC MOTOR

1. Position the planer on its side or in such a fashion that the planetary oil will not leak out when replacing the motor.
2. Tag and disconnect the power and return hoses along with the case drain hose from the hydraulic motor.
3. Remove the capscrews securing the motor to the planetary.
4. Scrape the mating surface of the planetary, removing all existing silicone, to prepare it for the new motor.
5. Apply new RV 10 silicone to the motor to seal the connection between the motor and the planetary. Bolt the new hydraulic motor onto the planetary using the existing hardware. (Check to ensure that the hydraulic motor is in the correct position with the ports turned up.) Torque to specification
6. Re-connect the hydraulic hoses and fittings to the motor.

MAINTENANCE & SERVICE

HYDRAULIC RESERVOIR

WARNING! Never perform work on the planer unless you are authorized and qualified to do so. Before performing maintenance, lower the planer to the ground, turn off the engine, remove the key and apply the brakes. Relieve pressure from the hydraulic system.



If oil is flowing into the reservoir there is something that needs to be corrected in the hydraulic circuit between the skid steer loader and the planer. The planer should be removed from service and tagged “DO NOT OPERATE” until corrected.

Oil leaking into the reservoir slowly could be caused by cold oil in the skid steer. It is recommended that the skid steer run for approximately 15 minutes before activating the auxiliary hydraulics and operating the cold planer.

TROUBLESHOOTING:

Oil flowing into the reservoir can be caused by a break in the hydraulic flow in the case drain circuit, exceeding the 50 PSI relief valve.

1. Bad connection between the planer case drain coupler and the skid steer loader coupler. Verify that the couplers are completely engaged. If Oil is still flowing into the reservoir go to step #2.
2. Faulty case drain coupler on planer or skid steer loader. Check to verify that oil flows freely through both couplers. If oil is still flowing into the reservoir go to step #3.
3. Restriction or obstruction in the hydraulic circuit between the motor and the reservoir. Check all hoses, fittings and couplers for obstructions, pinching or kinking which will restrict the oil flow. Replace any damaged hoses, fittings or couplers, remove any obstruction or reroute hoses to eliminate kinks. If oil is still flowing into the reservoir go to step #4.
4. Damaged o-ring in the skid steer auxiliary outlet manifold.

To check case drain line pressure:

- Attach gauge to case drain coupler on skid steer. Remove power and return lines.
- Run auxiliary hydraulics
- Gauge should not move. If gauges moves there is a broken seal in the auxiliary outlet manifold. Replace seal before operating planer.

SEAL
LOCATION

REMOVE
POWER AND
RETURN LINES

ATTACH GAUGE TO
CASE DRAIN



13300 11-1-17

MAINTENANCE AND SERVICE

CYLINDER SEAL REPLACEMENT

The following information is provided to assist you in the event you should need to repair or rebuild a hydraulic cylinder. When working on hydraulic cylinders, make sure that the work area and tools are clean and free of dirt to prevent contamination of the hydraulic system and damage to the hydraulic cylinders. Always protect the active part of the cylinder rod (the chrome section). Nicks or scratches on the surface of the rod could result in cylinder failure. Clean all parts thoroughly with a cleaning solvent before reassembly.

DISASSEMBLY PROCEDURE

IMPORTANT: Do not contact the active surface of the cylinder rod with the vise. Damage to the rod could result.

THREADED TYPE GLAND

1. Rotate the gland with a spanner wrench counterclockwise until the gland is free of the cylinder tube.
2. Pull the cylinder rod from the cylinder tube and inspect the piston and the bore of the cylinder tube for deep scratches or galling. If damaged, the piston AND the cylinder tube must be replaced.

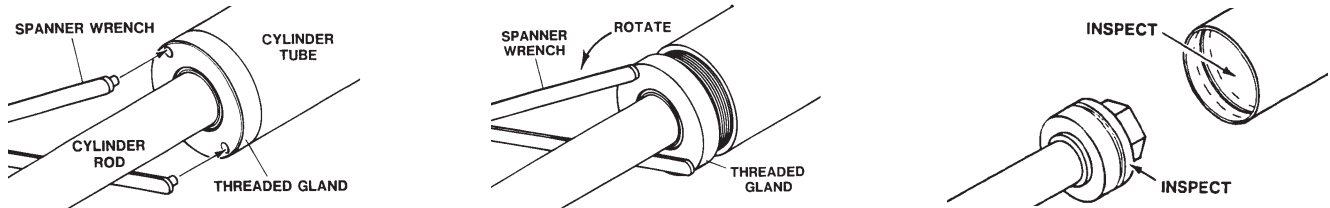

3. Remove the hex nut, piston, flat washer or spacer tube (if so equipped), and gland from the cylinder rod. If the cylinder rod is rusty, scratched, or bent, it must be replaced.
4. Remove and discard all the old seals.



ASSEMBLY PROCEDURE

IMPORTANT: Replace all seals even if they do not appear to be damaged. Failure to replace all seals may result in premature cylinder failure. **NOTE:** Seal kits will service most cylinders of similar bore size and rod diameter.

1. Install the cylinder rod seal in the gland first. Be careful not to damage the seal in the process, as it is somewhat difficult to install.

NOTE: A special installation tool (Part #65349) is available to help with installing the seal. Simply fit the end of the tool over the seal so that the large prong of the tool is on the outside of the seal, and the two smaller prongs on the inside. The lip of the seal should be facing towards the tool. Rotate the handles on the tool around to wrap the seal around the end of the tool.

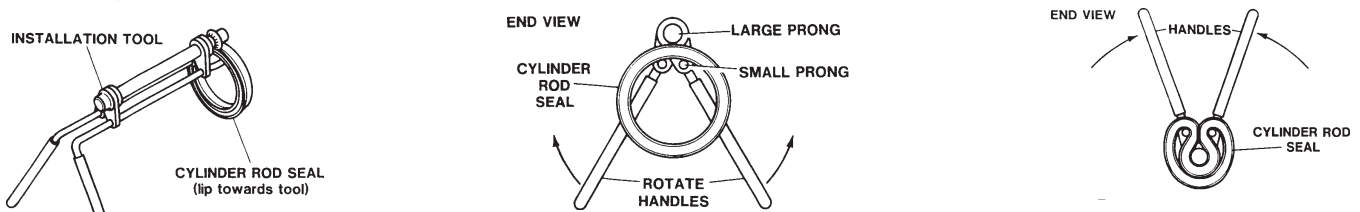

10356 10-13-05

MAINTENANCE AND SERVICE

Now insert the seal into the gland from the inner end. Position the seal in its groove, and release and remove the tool. Press the seal into its seat the rest of the way by hand.

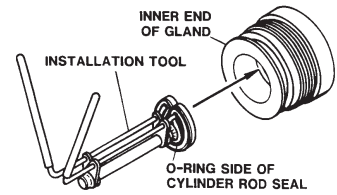

2. Install the new piston ring, rod wiper, O-rings and backup washers, if applicable, on the piston.

Be careful not to damage the seals. Caution must be used when installing the piston ring. The ring must be stretched carefully over the piston with a smooth, round, pointed tool.

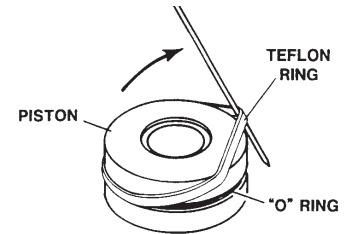

3. After installing the rod seal inside the gland, as shown in step #1, install the external seal.

NOTE: Threaded glands may have been equipped with a separate O-ring and backup washer system or a polypak (all in one) type seal. Current seal kits contain a polypak (all in one) type seal to replace the discarded seal types on ALL THREADED GLANDS.

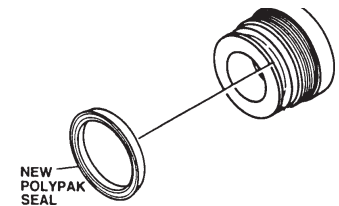

4. Slide the gland onto the cylinder rod, being careful not to damage the rod wiper. Then install the spacer, or flat washer (if so equipped), small o-ring, piston, and hex nut onto the end of the cylinder rod.
5. Secure the cylinder rod (mounting end) in a vise with a support at its center. Torque the nut to the amount shown for the thread diameter of the cylinder rod (see chart).

Thread Diameter	POUNDS - FEET
7/8"	150-200
*1"	230-325
1-1/8"	350-480
1-1/4"	490-670
1-3/8"	670-900
* 1" Thread Diameter WITH 1.25" Rod Diameter Min. 230 ft. lbs. Max. 250 ft. lbs.	

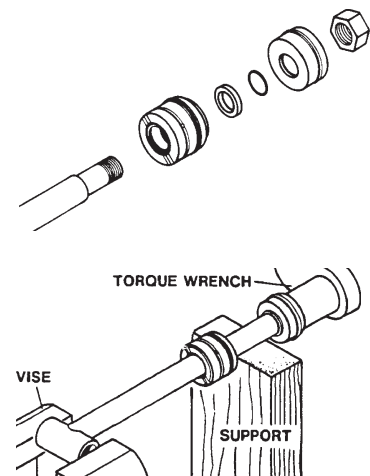

IMPORTANT: Do not contact the active surface of the cylinder rod with the vise. Damage to the rod could result.

6. Apply a lubricant (such as Lubriplate #105) to the piston and teflon ring. Insert the cylinder rod assembly into the cylinder tube.

IMPORTANT: Ensure that the piston ring fits squarely into the cylinder tube and piston groove, otherwise the ring may be damaged and a leak will occur.

7. Use a spanner wrench to rotate the gland clockwise into the cylinder. Continue to rotate the gland with the spanner wrench until it is tight.

WARNING!



Cylinders serviced in the field are to be tested for leakage prior to the attachment being placed in work. Failure to test rebuilt cylinders could result in damage to the cylinder and/or the attachment, cause severe personal injury or even death.

TROUBLESHOOTING

<u>PROBLEM</u>	<u>POSSIBLE CAUSE</u>	<u>POSSIBLE SOLUTION</u>
Motor on the planer will not operate.	Auxiliary hoses not hooked up to the skid steer.	Engage Couplers
	Obstruction in hydraulic lines.	Remove obstruction and replace if necessary.
	Hydraulic motor damaged or seals blown.	Call Bradco service department for instructions.
	Skid steer auxiliary valve not engaged.	Engage auxiliary valve.
Drum rotates sluggishly.	Insufficient hydraulic flow from the skid steer.	Refer to skid steer's owners manual. Replace if necessary.
	Damaged quick coupler.	Call Bradco service department for instructions.
	Hydraulic motor damaged or seals blown.	Call Bradco service department for instructions.
	Oil filter on skid steer is dirty.	Refer to skid steer's owners manual.
Leaking Oil.	Planer reservoir is full.	Remove from service and correct. See Maintenance & Service section.
	Loose or damaged hydraulic line.	Tighten or replace.
	O-Rings on fittings damaged.	Replace if necessary.
	Hydraulic motor damaged or seals blown.	Call Bradco service department for instructions.
	Fittings loose or damaged.	Tighten or replace.
	Cylinder seals damaged.	Replace cylinder seals.
Insufficient power.	Insufficient hydraulic flow from the skid steer.	Refer to skid steer's owners manual.
	Relief valve setting adjusted too low.	Refer to skid steer's owners manual.
	Hydraulic motor damaged or seals blown.	Call Bradco service department for instructions.
	Oil filter on skid steer is dirty.	Refer to skid steer's owners manual.
Drum rotates in the wrong direction.	Hoses from the valve to the motor incorrectly connected.	Switch hoses at the motor end.
Excessive vibration during planing operation.	Picks are worn or broken.	Visually inspect the picks and replace as necessary.
	Picks contain flat spots or are not rotating freely.	Visually inspect the picks and replace as necessary.
	Insufficient down force due to incorrect operating procedure.	Refer to the Operating section of this manual.

TROUBLESHOOTING

<u>PROBLEM</u>	<u>POSSIBLE CAUSE</u>	<u>POSSIBLE SOLUTION</u>
Excessive oil temperature.	Hydraulic oil level too low.	Refer to skid steer's owners manual
	Obstruction in hydraulic lines.	Remove obstruction and replace if necessary.
	Hydraulic oil or oil filter in skid steer is dirty.	Refer to skid steer's owners manual.
	Relief valve setting adjusted too low.	Refer to skid steer's owners manual.
	Couplers not engaged.	Engage couplers.
A Hydraulic cylinder not operating.	Insufficient hydraulic flow from the skid steer.	Refer to skid steer's owners manual.
	Cylinder rod bent.	Visually inspect cylinder for damage.
	Cylinder seals damaged.	Replace cylinder seals.
	Obstruction in hydraulic lines.	Remove obstruction and replace if necessary.
All hydraulic cylinders not functioning.	Blown fuse on skid steer.	Refer to skid steer's owners manual.
	Damaged electrical wiring.	Test and replace if necessary.
	Solenoid valve spool bent.	Replace spool.
	Nut on Solenoid valve too tight	Loosen nut.
Hydraulic cylinders only operating in one direction.	Contaminants in the hydraulic system and solenoid valve.	Remove spool from solenoid valve and check for foreign material. Clean or replace. Remove spool from solenoid valve and check seals for damage. Replace if necessary.
	Damaged electrical wiring.	Test and replace if necessary.
	Solenoid valve spool bent.	Replace spool.
	Nut on Solenoid valve too tight	Loosen nut.
Oil entering planer reservoir.	Cold start up.	Warm oil in skid steer for approximately 15 minutes before operation.
	Case drain coupler is not engaged.	Engage couplers.
	Obstruction in hydraulic lines.	Remove obstruction and replace if necessary.
	Faulty case drain coupler.	Ensure oil flows freely through both skid steer and attachment couplers.
	Damaged O-ring in auxiliary hydraulic manifold on skid steer.	Install pressure gauge in case drain line to verify. Replace O-ring. See Maintenance & Service.

9837B 10-31-17-4

SPECIFICATIONS

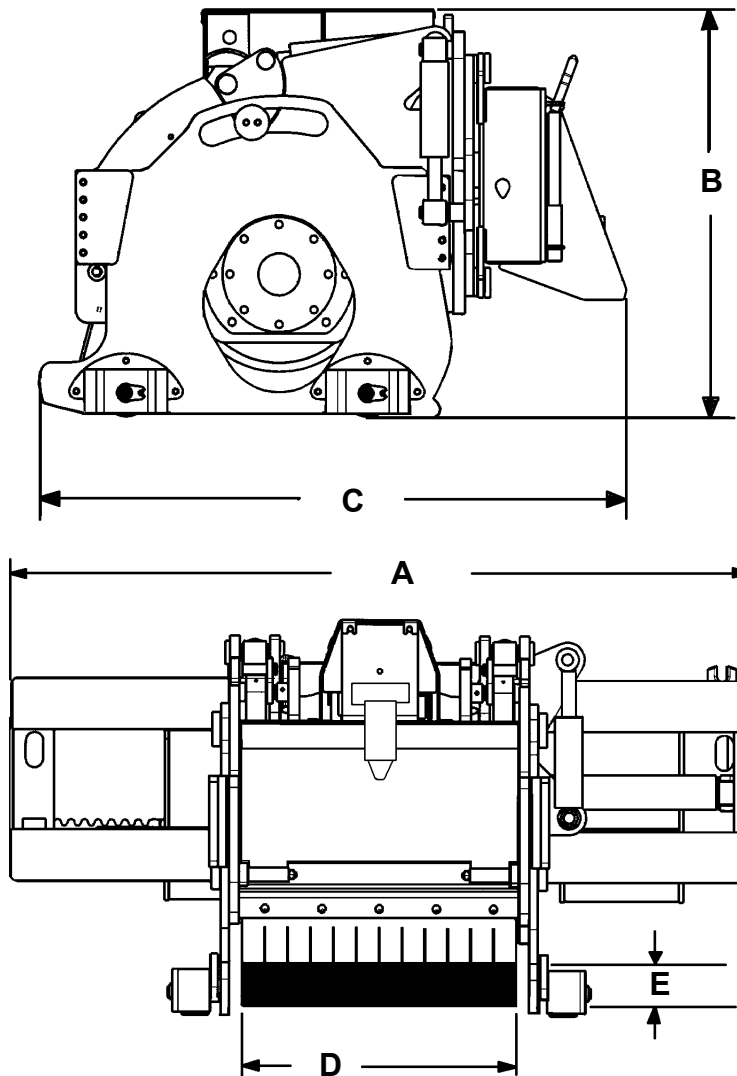

DESCRIPTION	SPECIFICATION				
	16"	18"	24"	30"	40"
A. Overall Width	64.94"	64.94"	64.94"	64.94"	64.94"
B. Overall Height	34.57"	34.57"	34.57"	34.57"	34.57"
C. Overall Length	50.30"	50.30"	50.30"	50.30"	50.30"
D. Planing Width.....	16.00"	18.00"	24.00"	30.00"	40.00"
E. Planing Depth	0"-5.00"	0"-5.00"	0"-5.00"	0"-5.00"	0"-5.00"
Drum Diameter.....	22.00"	22.00"	22.00"	22.00"	22.00"
Number of Picks (Full size drum)	43	45	57	69	89
Weight (lbs).....	2150#	2200#	2400#	2600#	3100"
High Flow Requirement	22-40 GPM				
Operating Pressure Relief Setting.....	3800 PSI				



BOLT TORQUE SPECIFICATIONS

GENERAL TORQUE SPECIFICATION TABLES

Use the following charts when determining bolt torque specifications when special torques are not given. Always use grade 5 or better when replacing bolts.



SAE BOLT TORQUE SPECIFICATIONS

NOTE: The following torque values are for use with extreme pressure lubricants, plating or hard washer applications. Increase torque 15% when using hardware that is unplated and either dry or lubricated with engine oil.

Bolt Size		SAE GRADE 5 TORQUE				SAE GRADE 8 TORQUE				Bolt head identification marks as per grade. NOTE: Manufacturing Marks Will Vary
		Pounds Feet		Newton-Meters		Pounds Feet		Newton-Meters		
Inches	Millimeters	UNC	UNF	UNC	UNF	UNC	UNF	UNC	UNF	
1/4	6.35	8	9	11	12	10	13	14	18	<p>GRADE 2</p>  <p>GRADE 5</p>  <p>GRADE 8</p> 
5/16	7.94	14	17	19	23	20	25	27	34	
3/8	9.53	30	36	41	49	38	46	52	62	
7/16	11.11	46	54	62	73	60	71	81	96	
1/2	12.70	68	82	92	111	94	112	127	152	
9/16	14.29	94	112	127	152	136	163	184	221	
5/8	15.88	128	153	174	207	187	224	254	304	
3/4	19.05	230	275	312	373	323	395	438	536	
7/8	22.23	340	408	461	553	510	612	691	830	
1	25.40	493	592	668	803	765	918	1037	1245	
1-1/8	25.58	680	748	922	1014	1088	1224	1475	1660	
1-1/4	31.75	952	1054	1291	1429	1547	1700	2097	2305	
1-3/8	34.93	1241	1428	1683	1936	2023	2312	2743	3135	
1-1/2	38.10	1649	1870	2236	2535	2686	3026	3642	4103	

METRIC BOLT TORQUE SPECIFICATIONS

NOTE: The following torque values are for use with metric hardware that is unplated and either dry or lubricated with engine oil. Reduce torque 15% when using hardware that has extreme pressure lubricants, plating or hard washer applications.

Bolt head identification marks as per grade.		
		

Size of Bolt	Grade No.	Pitch (mm)	Pounds Feet	Newton-Meters	Pitch (mm)	Pounds Feet	Newton-Meters
M6	5.6	1.0	3.6-5.8	4.9-7.9	-	-	-
	8.8		5.8-4	7.9-12.7		-	-
	10.9		7.2-10	9.8-13.6		-	-
M8	5.6	1.25	7.2-14	9.8-19	1.0	12-17	16.3-23
	8.8		17-22	23-29.8		19-27	25.7-36.6
	10.9		20-26	27.1-35.2		22-31	29.8-42
M10	5.6	1.5	20-25	27.1-33.9	1.25	20-29	27.1-39.3
	8.8		34-40	46.1-54.2		35-47	47.4-63.7
	10.9		38-46	51.5-62.3		40-52	54.2-70.5
M12	5.6	1.75	28-34	37.9-46.1	1.25	31-41	42-55.6
	8.8		51-59	69.1-79.9		56-68	75.9-92.1
	10.9		57-66	77.2-89.4		62-75	84-101.6
M14	5.6	2.0	49-56	66.4-75.9	1.5	52-64	70.5-86.7
	8.8		81-93	109.8-126		90-106	122-143.6
	10.9		96-109	130.1-147.7		107-124	145-168
M16	5.6	2.0	67-77	90.8-104.3	1.5	69-83	93.5-112.5
	8.8		116-130	157.2-176.2		120-138	162.6-187
	10.9		129-145	174.8-196.5		140-158	189.7-214.1
M18	5.6	2.0	88-100	119.2-136	1.5	100-117	136-158.5
	8.8		150-168	203.3-227.6		177-199	239.8-269.6
	10.9		175-194	237.1-262.9		202-231	273.7-313
M20	5.6	2.5	108-130	146.3-176.2	1.5	132-150	178.9-203.3
	8.8		186-205	252-277.8		206-242	279.1-327.9
	10.9		213-249	288.6-337.4		246-289	333.3-391.6

PARTS

In order to provide you with the most UP-TO-DATE part information, all parts for this attachment have been moved to our website at www.paladinattachments.com/Manuals. Please use these diagrams and parts lists to locate replacement parts.

When servicing your attachment, remember to use only original manufacturer replacement parts. Substitute parts may not meet the standards required for safe, dependable operation.

To facilitate parts ordering when contacting the factory, please have the product control number (PCN) or model and serial number of your product ready to ensure that you receive the correct parts for your specific attachment.

The product control number (PCN), model and serial number for your attachment should be recorded in the space provided on the cover of this manual. This information may be obtained from the serial number identification plate located on your attachment.

NOTE: Most daily and emergency parts orders (in stock) received by 10:30 A.M. (Eastern Standard Time) will be shipped UPS Ground the same day received. UPS Next Day orders must be received by 1:30 PM (Eastern Standard Time.)

SERVICE DEPARTMENT

(734) 996-9116

(800) 456-7100

For Fax and E-mail Orders

PLC_Sales@paladinattachments.com

(734) 996-9014

WARRANTY

In order to provide you with the most UP-TO-DATE Warranty information, Paladin Warranty Statement and Warranty Procedures along with Warranty Registration and Claim Forms have been moved to our website at www.paladinattachments.com.

13033 8-4-16-2