



Boom Mower

Ref. 10.DL.1000/1000-C



Boom Mower

Ref. 10.DL.1000/1000-C



- Hydraulic boom mower, perfect for road maintenance and other applications. For use with hydrostatic machines.
- Ease of visibility during operation for operators comfort
- Electro Hydraulic control valves for smooth and precise operation (proportional controls also available as an option). Hydraulic flow regulator for control of speed for boom movements
- Hydraulic safety system to protect boom from damage.
- Auto-Self leveling system on first section of boom
- Optional pruning heads, sign cleaning brushes, root puller/cutters, floating mower couplers, etc. can easily be interchanged

Dimensions	10DL1000	10DL1000-C
A (Maximum Horizontal Height)	63 in.	54 in.
B	174 in.	135 in.
C	178 in.	39 in.
D	63 in.	42 in.
E	37 in.	37 in.
F	215 in.	174 in.
G	34 in.	40 in.

All data subject to change without previous notice.

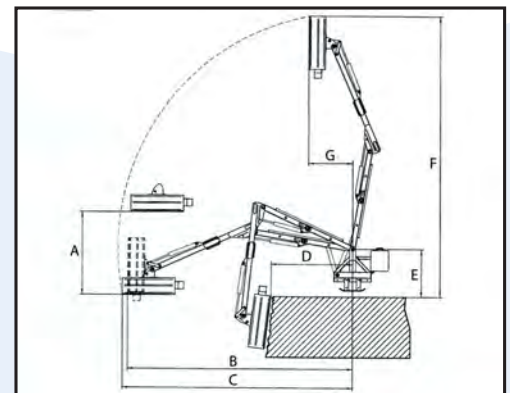

OFFICE
6535 NW 84th Ave.
Miami, Florida, 33167
Tel. +1-786-542-6122
info@coneac.com
www.coneac.com



Factory
Pol. Ind. La Pobla, nave 19-21
08260 Súria (BCN) SPAIN
Tel. +34 93 869 40 50 - Fax +34 93 868 25 77
euroimplementos@euroimplementos.com
www.euroimplementos.com



Empresa Certificada
UNE-EN-ISO 9001