

4-150HDX



Carriers

13 - 18 ton Excavators
5 - 8 ton Loaders

Weight

860kgs

Capacity

0.60m³

Flow

90 lpm

Screening Area

615mm x 1500mm

Dimensions

A - 615mm D - 1900mm

B - 1500mm E - 1000mm

C - 715mm F - 890mm

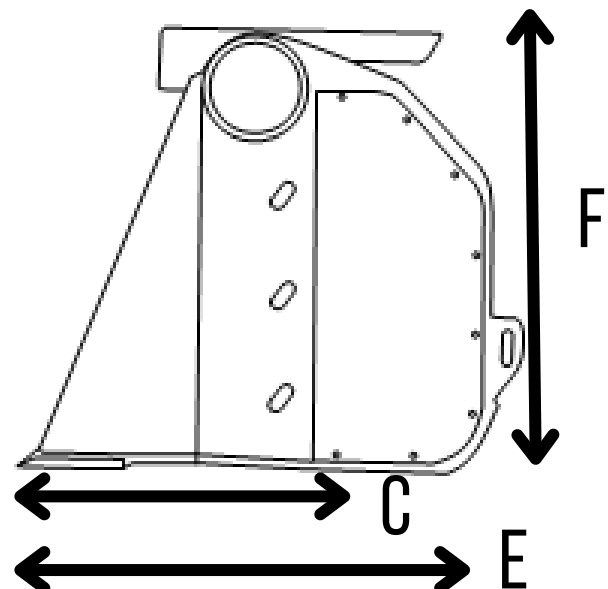
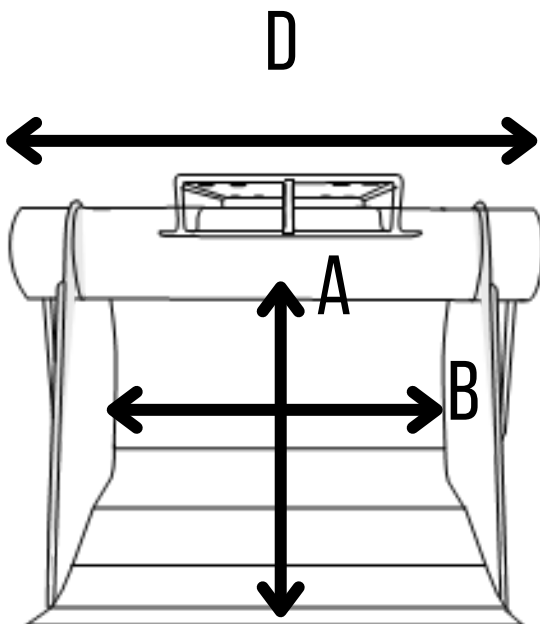

True Compact Screening
Low maintenance System
Poly-Stars screen without crushing
Non-stick floor as standard