

# 6-150HDX



## Carriers

16 - 24 ton Excavators  
6 - 10 ton Loaders

## Weight

1360kgs

## Capacity

1.20m<sup>3</sup>

## Flow

150 lpm

## Screening Area

1030mm x 1500mm

## Dimensions

A - 1030mm D - 1900mm

B - 1500mm E - 1340mm

C - 1000mm F - 1300mm

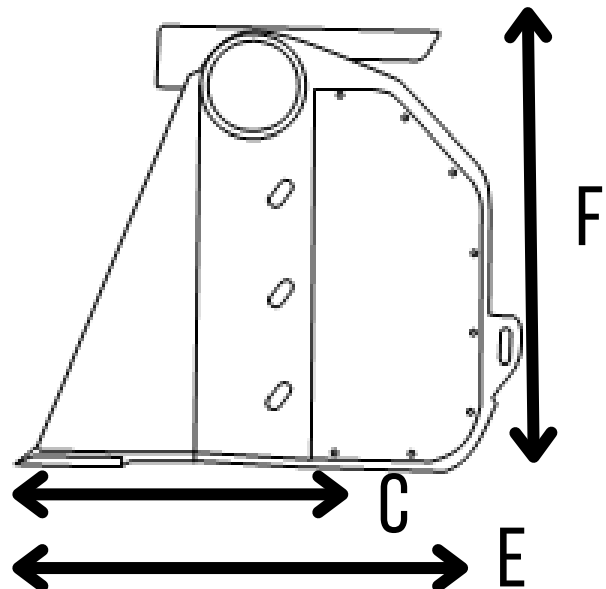
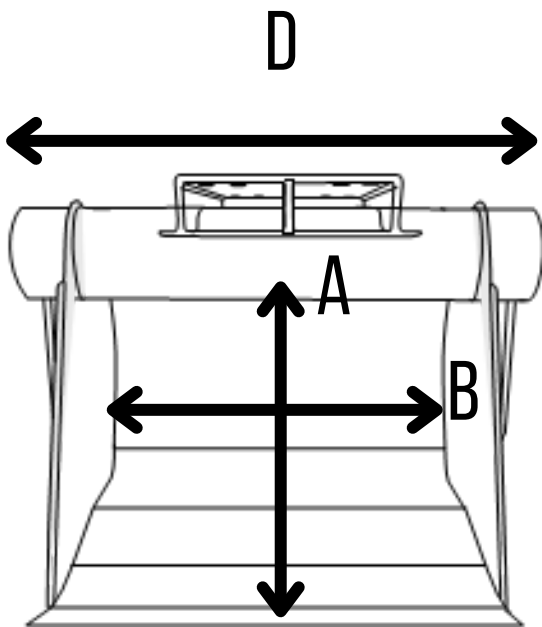

True Compact Screening  
Low maintenance System  
Poly-Stars screen without crushing  
Non-stick floor as standard