



RCR812 Hay Runner Hay Rake

Instruction Manual and Parts List For Hay Rakes after serial #01013

**Use this manual for safety instructions and operating instructions.
Make sure that everyone who operates this machine has read this
manual completely!**

Save for future use.

**Manufactured by:
Ogden Metalworks Inc.
PO Box 128 <> 301 N. Marilyn Avenue
Ogden, IL 61859
PH: 217-582-2552 <> Fax 217-582-2746
www.ogdenmetalworks.com
1-18N2218**

Quick Reference Guide

Note: The minimum tractor hydraulic system requirement for the **RCR812** Hay Runner is 1900 psi.

Grease All Pivot Points

Before using the rake all pivot points should be greased. This includes the mainframe hinge, pivot hinge, rake arm hinge, transport hub, rake wheel hubs, tandem pins (optional), and center wheel pins (optional). The zerks for the rake arms are on the bottom side of the I Series tubes. When greasing these be sure to move the rake arms up and down several times to insure proper lubrication.

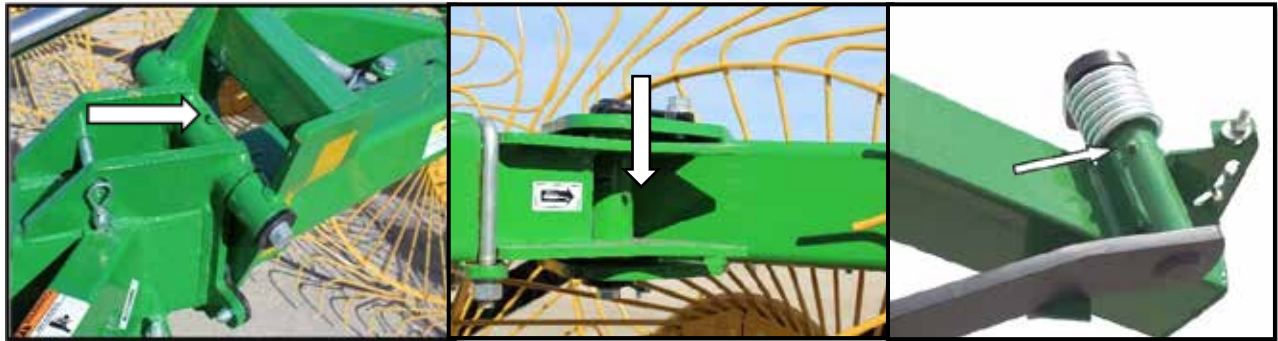

Tongue Extension

The tongue extension on the RCR812 comes standard with every rake. Depending on the size of rake you have purchased the tongue extension can be removed to shorten the length of the tongue for maneuverability on an 8 wheel rake. **Note:** the tongue extension is required to mount the Dual Center Wheel kit if purchased. **“Important”** Before adding or removing the tongue extension, fold both wings all the way down so the rake wheels rest on the ground. Place the jack stand in the transport jack plug located on the left hand inside of the side brace on the center weldment facing down towards the ground. Using a large and sturdy block, jack up the front until you have relieved the weight on the clevis. Now loosen the hose holder on top of the tongue so the hoses will slide through. Then loosen the 6 – 5/8” bolts that hold the tongue together so that you can move the front of the tongue forward or backward to re attach the tongue. Make sure you get all of the 5/8” bolts tight when attaching the tongue and before operation.

Tongue Clevis Adjustment

It is **VERY** important that the RCR812 Hay Runner operates level. *“Important”* The tongue clevis is adjustable and should be adjusted so the rake is as level as possible when raking.



Transport Locks

The rake is shipped with the transport locks in the locked position. This is to prevent the wings from coming down unexpectedly. Before applying pressure to the hydraulics, make sure that you unlock the transport locks and pin them in the unlocked position. *Note:* If transport locks are not unlocked and pressure is applied to the hydraulics, the transport lock is designed to break away if enough pressure is applied to them or if they are worked back and forth. If this happens make sure you contact your dealer and replace the transport locks before operating.



Installing the I Series Arms

If you have to attach the I Series Rake Assembly to the pivot arm, use the 3/4" x 4" U-bolts, lockwashers and hex nuts. The I Series Rake Assembly should be mounted where indicated on the tube to start out. If the tube is not marked, measure 95-1/2" from the rear edge and mark the tube. It may be necessary to adjust the mounting location to provide proper clearance (the mark on the tube is a quick reference guide for installation). Be sure to tighten the u bolts so the 4" x 4" I series tube is as level as possible on the rake.

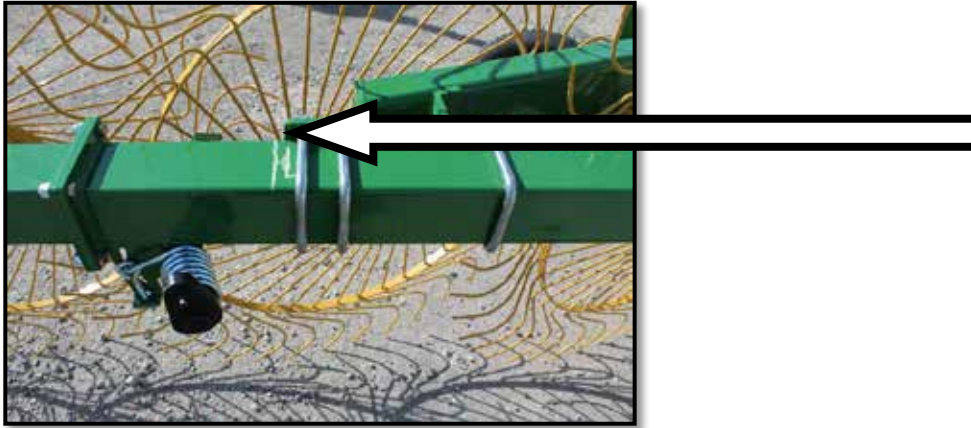

Installing Rake Wheels

The RCR812 Hay Runner has right and left hand rake wheels and it is important that they are installed correctly. The rake tines at the bottom of the wheel where the tine touches the ground should point forward (toward the tractor). The carriage bolt heads in the center of the wheel that bolt down the rake tines should be on the side of the wheel that touches the hay.

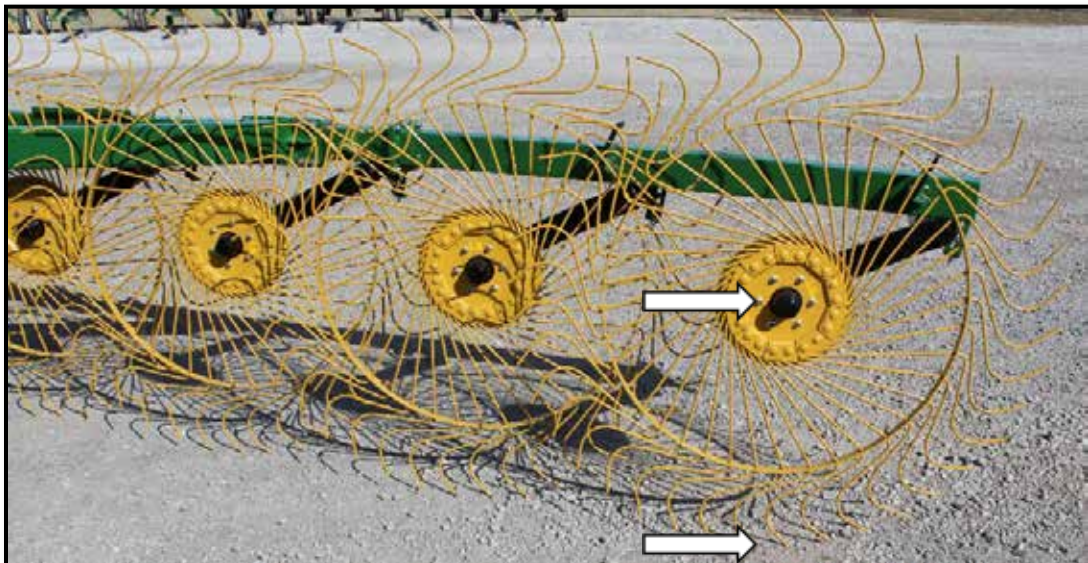

Wing Adjustment

The RCR812 Hay Runner is normally shipped with the wings adjusted all the way inward. Loosen the 3/4" U-bolts and move the rake assemblies outward to achieve a wider raking width and/or windrow. The rear 2 rake wheels can be independently adjusted without affecting the overall raking width. This allows operating the rake at a wide pitch in lighter crops while maintaining a wide windrow or operating the rake at a narrow pitch in heavy crops and maintaining a narrow windrow.

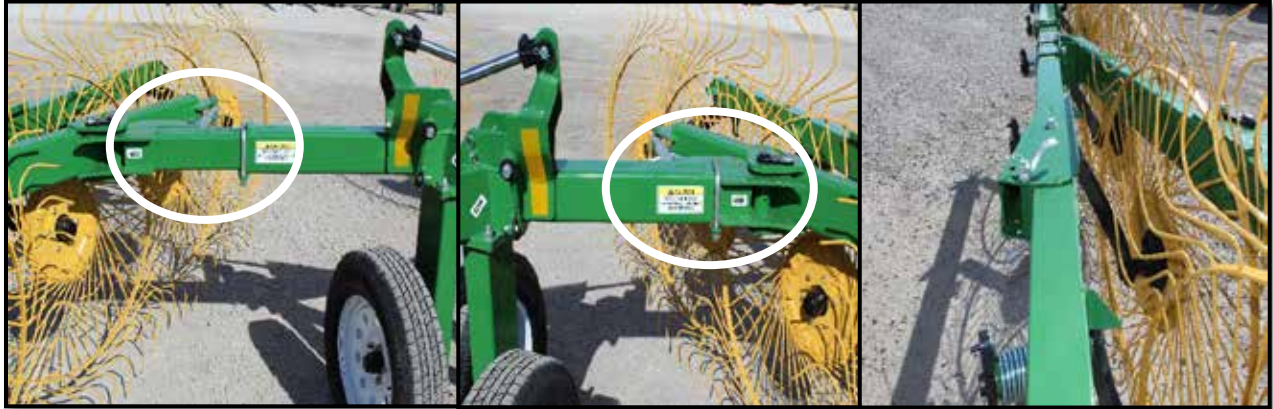

Front Wheel Adjustment

The front rake wheel on the RCR10 can be lifted and held up during operating in order to reduce the overall raking width. The front 1 or 2 rake wheels on the RCR12 can be lifted as well. This is done by removing the keeper pin and clip. Raise the wheel, turn the clip over and install over the arm. Replace the keeper pin.



Rake Angle Adjustment

The rake angle is adjusted by loosening the threaded latch on the turnbuckle and pivoting the rake assembly. When the desired angle is achieved be sure to retighten the latch.



Adjusting Rake Wheel Ground pressure

Rake Wheel ground pressure can be controlled by adjusting the torsion spring on each wheel. Tighten the nut on the eye bolt to **Decrease** the ground pressure which will cause less wear on rake teeth in lighter hay. Loosen the nut to **Increase** the ground pressure which will help pick up heavier hay.

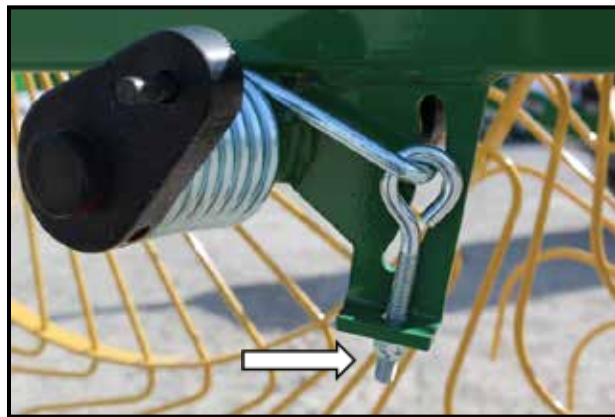

The rake wheels are ground driven and require ground contact in order to operate properly. Adjust the wheel ground pressure to achieve good raking action without damaging the crop. Do not exceed the amount of rake wheel ground pressure necessary. Excessive rake wheel ground pressure can cause crop damage and premature rake wheel tine wear.

Table of Contents

Table of contents 1

Introduction 2

Safety Instructions 3

Decals 4

Assembly 5

Hydraulic System 9

Operation 9

Ground Pressure Adjustment 11

Operating with one rake12

Transporting 13

Maintenance 14

Lubrication 15

Tandem Axle Installation 16

Center Wheel Kit Installation 15

Product Drawings/Parts Lists

Introduction

The **RCR812** Hay Runner Hay Rake has been engineered and built for ease of operation and long service life. This Operator's Manual will provide important safety and operational information. It is important that you thoroughly understand the operation of the **RCR812** Hay Runner Hay Rake before use. Failure to follow the instructions in this manual may result in personal injury and/or damaged equipment and could void the warranty. Please do not assume you know how to operate and maintain this machine before you have completely read this manual. Store this manual in the Manual Canister on the tongue for future reference.

Read through this manual completely, watching especially for safety symbols (see illustration below) which will alert you to possible safety hazards. This safety alert symbol is used throughout this manual to identify possible safety hazards.



The word "**Note**" will alert you to special information such as specifications, techniques, reference information and other supplementary information. It is the user's responsibility to read the operator's manual and comply with all the instructions pertaining to operation and maintenance. It is also the user's responsibility to inspect the machine at regular intervals and repair or replace worn or damaged parts when continued use would cause damage or excessive wear to other parts. The word "**Important**" is used to point out a note which is of an immediate and urgent nature.

The manufacturer reserves the right to make improvements, discontinue or change specifications, models or design without notice and without incurring obligation.

When ordering parts, for your **RCR812** Hay Runner Hay Rake, please specify the part number and the part description as shown in the parts listing in this manual. Please give the serial number of the **RCR812** Hay Runner Hay Rake in all correspondence when referring to the Hay Rake. Please record the following information here for future use.

Serial Number _____

Model _____ **Purchase date** _____

Dealer _____

Address _____

Phone number _____

IMPORTANT: When this machine is traded or sold, make sure this manual accompanies the machine so future operators will have complete operating instructions and safety warnings available to them.

Safety Instructions



CAUTION: This machine should never be operated by anyone who is not familiar with the product and has not read the instruction manual. Do not allow children to operate the Hay Rake.

All persons operating this machine should read and understand the Instruction Manual.

Read and understand all safety decals located on the machine.

Keep Safety Decals clean and legible at all times.

Replace Safety Decals that are missing or become illegible.

Do not allow anyone to ride on the machine.

Be sure machine is attached securely to the tractor before operating or transporting.

Inspect the *RCR812* Hay Runner before daily use. Lubricate and repair or replace parts as needed.

Maintain and keep all Safety Shields in place.

Make sure the Wings are locked whenever they are in the folded position before working around the machine or for transporting.

Before operating the machine inspect for loose or damaged bolts or parts and make necessary repairs before starting.

All bystanders should be a safe distance from the machine when in operation.

High-pressure oil leaks can penetrate skin causing serious injury. Do not use your finger or other skin to check for leaks.

Apply parking brake and stop tractor engine before dismounting tractor.

Keep hands, feet and clothing away from moving parts.

Never transport faster than surface conditions allow.

Display the SMV Emblem when transporting with a tractor.

Make sure you are in compliance with all local regulations regarding transporting agriculture equipment on public roads and highways. Consult your local law enforcement agency for further details.

Ensure that the Slow Moving Emblem (SMV) and all reflectors and lights required by the local highway and transport authorities are in place and are clean and visible by overtaking and oncoming traffic.

Decals

Important: The following decals or similar decals are located on your *RCR812* Hay Runner Hay Rake. Before you operate the *RCR812* Hay Runner Hay Rake, read and understand the purpose for each decal. Replace any damaged decals. Keep all decals clear and readable.

1.



2.



3.



4.



5.

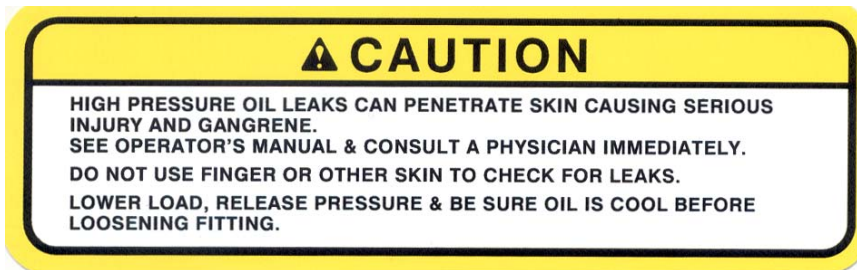

6.

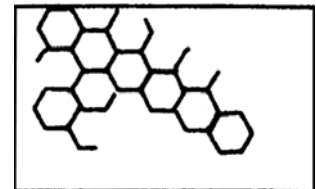

7.

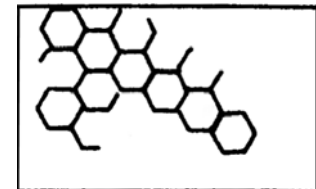

Decal Parts List

Item No.	Part No.	Description	Qty.
1	HR169	Decal, Warning Operating	1
2	HR170	Decal, Overhead Hazard	2
3	0-70	Decal, Caution Stay Clear	5
4	HR171	Decal, Warning Pinch Point	2
5	0-82	Decal, Hydraulic Caution	1
6	0-71	Decal, Red Reflector	2
7	B489A	Decal, Yellow Reflector	2

ASSEMBLY INSTRUCTIONS

CAUTION!



Wear proper protective equipment such as safety glasses and protective shoes when assembling.

CAUTION!



Always wear protective eye goggles and use a magnifying glass or use a piece of wood on suspected leaks. Pinhole hydraulic leaks can penetrate skin causing disease or death. Do not touch.

CAUTION



Make sure the area around the machine is clear before lowering. Do not lower machine when people, animals, or property are near the machine or folding mechanism.

Use the following assembly instructions if you received the **RCR812** Hay Runner Hay Rake partially or completely unassembled. The assembly area should be a clean flat solid surface. It may be necessary to use lifting mechanisms and sturdy supports. When reading the assembly instructions, the directions (**LEFT** and **RIGHT**) are always referred to from standing behind the piece of equipment (**BACK**) looking forward toward the tractor (**FRONT**).

1. Lay out and identify all parts. Many parts will be partially assembled.
2. Support the main frame on sturdy stands (16). Install the tongue extension (12) on the main frame using a quantity of 6 - 5/8" x 2" hex capscrews (13), lockwashers (14) and hex nuts (15). Next attach the tongue to the tongue extension using another quantity of 6 - 5/8" x 2" hex capscrews (13), lockwashers (14) and hex nuts (15). Depending on the size of the rake or options ordered, the tongue extension does not have to be installed on an 8 wheel and possibly 10 wheel rake depending on clearance with the tractor you have. **Note:** tongue extension is required for mounting the Dual Center Wheel kit.



3. Before installing the axles (24), place them upside down so that you can look through the square welded 1/2" nut in the bottom. Then slide in the spindles (13) with the drilled indentation up so you can see when it appears through the welded nut (the backside of the spindle will stick out about a 1/2" of the axle weldment). Thread the 1/2" jam nut (17) on the 1/2" x 1-1/2" square head set screw (18) all the way up to the head of the setscrew. While making sure the spindle does not move, tighten down the spindle in the axle weldment using the setscrew. Tighten the jam nut to ensure the set screw will not unthread. Install the axles to the rear of the main frame using a quantity of 8 - 5/8" x 2" hex capscrews (13), lockwashers (14) and hex nuts (15). Attach the SMV bracket (17) to the LH wheel axle bolts as shown in the picture below. Mount tires and rims to hubs using lug bolts. Torque lug bolts to 75 ft-lbs.



4. Attach the manual canister (10) to the tongue using a quantity of 2 - 3/8" x 1" hex capscrews (7). In front of the manual canister install the hose holder (8) using a 3/8" x 1" hex capscrew (7) and lockwasher (9). Leave the hose holder loose so the hoses can be placed through them later in assembly.



5. Install the tongue jack stand (6) on the tongue using the pin supplied.

6. Attach the clevis (2) to the tongue using a quantity of 2 - 5/8" x 7" hex capscrews (1) and nylock hex nuts (3). The height of the clevis can be adjusted to match the drawbar height of the tractor. The Hay Rake should always be level for proper operation.

7

7. Mount the right hand (28) and left hand (20) wings to the main frame using the hinge pins (22). Clean and lubricate the hinge pins before installing. After installing the hinge pins, attach the pin retainer (51) using a 3/4" x 1-1/4" hex capscrew () and lockwasher (). Secure the pin in place using a 5/8" x 2-1/2" hex capscrew (42), bushing (31), lockwasher (14), and hex nut (15).



8. Attach the wing extension arms (21) using the 3/4" x 4" U-bolt (29) and wrench nut (). The location of the wing extension arm varies depending on windrow or raking width desired. Typically, they will be half way out on the wing as possible but will vary depending on preference.

9. Mount the right hand (36) and left hand (35) pivot arms onto the wing extension arm using the pivot pins (33). Clean and lubricate the pivot pins before installing. After installing the pivot pins, attach the pin retainer (19) using a 5/8" x 1-1/4" hex capscrew (41) and lockwasher (14). Secure the pin in place using a 5/8" x 1-1/2" hex capscrew (40), lockwasher (14), SAE flatwasher (7).

11. Attach the end of the turnbuckle with the threaded latch to the wing extension arm using a 3/4" x 5" hex capscrew (45), a quantity of 2 - bushings (31), and a 3/4" nylock hex nut (43). Then attach the turnbuckle to the pivot arm using a 3/4" x 4" hex capscrew (44), and 3/4" nylock hex nut (43).



12. Attach the I series rake assembly to the pivot arm using a quantity of 2 – 3/4” x 4” U-bolts (29), lockwashers (), and hex nuts (). The I series rake assembly should be mounted where indicated on the tube. If the tube is not marked measure 96-1/4” from the rear edge of the tube and mark the tube. After mounting the I series rake assembly, check for wheel clearance (the mark on the tube is a quick reference guide for installation). It may be necessary to adjust the mounting location to provide proper clearance. Be sure to tighten the U-bolts so the 4” x 4” I series tube is as level as possible on all rakes

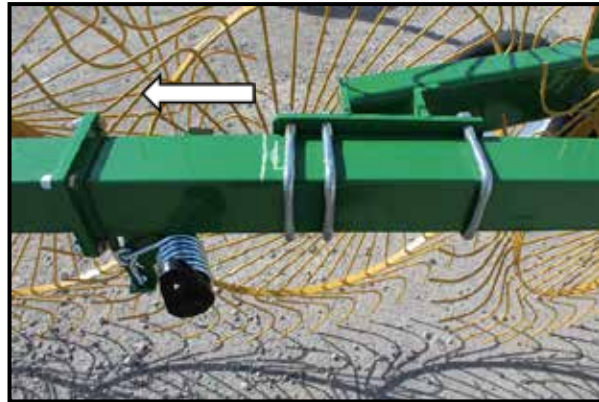

~ 95-1/2”

13. Mount the right hand and left hand rake wheels to the rake wheel hubs using 3/8” flange nuts (5). Standing behind the rake and looking forward the rake wheels marked RH go on the right side and the rake wheels marked LH go on the left side with the smooth carriage bolt heads towards the hay and the rake tooth at the bottom of the wheel pointing forward.

14. Attach the transport locks (18) to the main frame using a 5/8” x 2” hex capscrew (13), SAE flatwasher (47), nylock hex nut (3).

9

Hydraulic System

Note: The tractor hydraulic requirement for the RCR812 Hay Runner is 1900 psi.

Keep hoses and fittings clean at all times. Be sure all connections are properly sealed to avoid leakage. *Note:* Do not use Teflon thread tape. Only use a liquid type thread sealant.

CAUTION!



Operate the hydraulic cylinders through the cycle a few times to expel all air from the system. Failure to fully charge the hydraulic system could result in injury or death when the rakes fall abruptly to the ground.

CAUTION!



Always wear protective eye goggles and use a magnifying glass or use a piece of wood on suspected leaks. Pinhole hydraulic leaks can penetrate skin causing disease or death. Do not touch.

Note: If fluid penetrates the skin, it must be surgically removed within a few hours by a doctor familiar with the form of injury. If not taken care of gangrene or death may result. Make sure the weight of the machine has been taken off the hydraulic cylinder before disconnecting hydraulic hoses.

Operation

Before operation, check tightness of lug bolts, spindle set screws, and all other capscrews and nuts. Grease all pivot points including the mainframe hinge, pivot hinge, rake arm hinge, transport hub, rake wheel hubs, tandem pins (optional), and center wheel pins (optional).

Important: Before operation, the operator should be familiar with these operation instructions and operation of the tractor. Do not allow an unqualified person or one under the influence of medication or intoxicating substances to operate the tractor.

1. It is very important that the RCR812 Hay Runner is level in the operating position. In order to level the implement, remove the bolts and adjust the clevis up or down so that the rake is level. Connect the machine to the tractor tongue using a 3/4" or 1" hitch pin with retaining clip. The adjustable jack will allow the tongue to be raised or lowered during hookup. After hookup to the tractor, be sure to store the jack by mounting it on the extra mount provided just inside the side arm brace of the main frame.

2. Connect the hydraulic inlet and outlet hoses to the tractor system.

CAUTION!

Do not exceed manufacturers' maximum hydraulic system pressure 3000 psi.

3. To lower the rakes to the working position, turn off tractor and remove key. Remove the transport lock pins for each wing and rotate the transport locks out of the way. Store the transport lock pins back in the transport lock. Rotate the shut off valves to the open position or in line with the hoses. Apply hydraulic pressure to the cylinders and lower the wings to the ground.

CAUTION!

Make sure the area around the machine is clear before lowering. Do not lower machine when people, animals, or property are near the machine or folding mechanism.

4. The overall rake working width is adjusted by loosening the 3/4" U-bolts and sliding the wing extension assembly in or out to the desired windrow width or raking width. Be sure to retighten the U-bolts. The rear 2 wheels on the I series tubes can be adjusted to narrow or widen the windrow without affecting the overall raking width. Remove the locking pin and adjust the 2 wheel section in or out to obtain the desired windrow width. Replace the pin and tighten the wrench nut. This allows operating the rake at a wide pitch in lighter crops while maintaining a wide windrow or operating the rake at a narrow pitch in heavy crops and maintaining a narrow windrow.



Front Rake Wheel Adjustment – The front rake wheel on the RCR10 can be lifted and held up during operating in order to reduce the overall raking width. The front 1 or 2 rake wheels on the RCR12 can be lifted as well. This is done by removing the keeper pin and clip. Raise the wheel, turn the clip over and install over the arm. Replace the keeper pin.

11

5. The rake angle is adjusted by loosening the threaded latch on the turnbuckle and pivoting the rake assembly. When the desired angle is achieved be sure to retighten the latch.



6. Begin raking at a slow ground speed until you are familiar and comfortable with the rake. Working speed is normally 6 to 10 mph. Ground speed will vary with different hay conditions or terrain.

7. To raise the rakes, apply hydraulic pressure to the hydraulic cylinders. When the wings are in the fully raised position, install the transport locks and pins and close the hydraulic lock valve to each wing.

8. Rake Wheel ground pressure can be controlled by adjusting the torsion spring on each wheel. Tighten the nut on the eye bolt to **Decrease** the ground pressure which will cause less wear on rake teeth in lighter hay. Loosen the nut to **Increase** the ground pressure which will help pick up heavier hay.

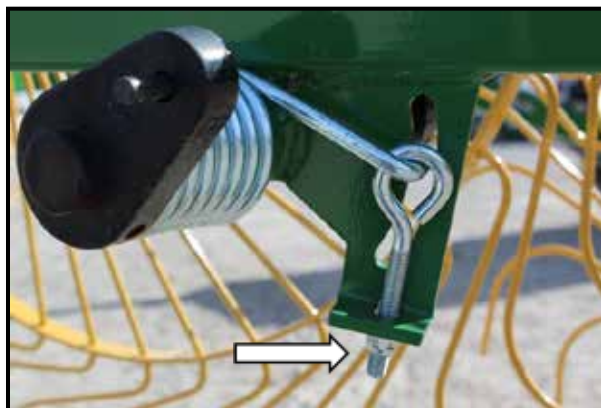

The rake wheels are ground driven and require ground contact in order to operate properly. Adjust the wheel ground pressure to achieve good raking action without damaging the crop. Do not exceed the amount of rake wheel ground pressure necessary. Excessive rake wheel ground pressure can cause crop damage and premature rake wheel teeth wear.

CAUTION!



Before doing any maintenance, adjustments or repairs on the machine, shut off the tractor engine, remove the ignition key and wait until all moving parts stop.

Operating one side of the rake

In order to operate with just one rake down, it is necessary to remove the transport lock and pin and open the hydraulic transport lock valve, located at the hydraulic cylinder, for the rake that you want to use. The open position is when the valve handle is in line with the valve body. Be sure the transport lock and pin are in place on the rake that you do not want to lower and that the hydraulic transport lock valve located at the hydraulic cylinder is closed. It is necessary to open the hydraulic bypass valve when raking with just one rake. The open position is when the handle is in line with the valve body. Be sure to close the bypass valve when using both rakes. Refer to decal on frame above Bypass valve for proper setting.

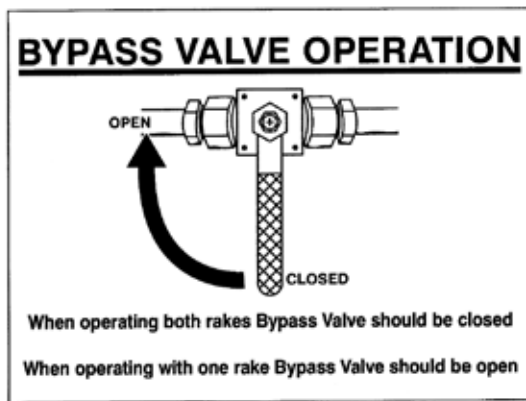

Bypass valve

Transport lock valve
(in open position)

CAUTION!



Before lowering the rake make sure all bystanders are a safe distance out of the way. Allow ample clearance around the implement when raising or lowering the rakes.

13

Transporting

CAUTION!



Never transport rakes without the hydraulic valves closed and Transport Locks and locking pins in place.

Make sure the rakes are in the raised transport position. Close the hydraulic transport lock valves and make sure the transport locks and pins are in place locking the rakes. Avoid sharp turns during transport. Slow down when approaching trees, fences, ditches, turns, or curves to avoid damage to the rakes and injury or death. Transport at tractor speed. **Do not exceed 20 MPH.**

When transporting the RCR812 Hay Runner, make sure you have your SMV sign in the bracket mounted on the rear of the rake.



CAUTION!



When towing on public roads, a slow moving vehicle (SMV) sign must be installed on the rake so it is visible to vehicles following. Comply with state and local safety requirements at all times.

MAINTENANCE

1. Check periodically and replace any damaged or missing safety decals.
2. Check hydraulic hoses periodically for cracks, abrasions or leaks. Replace defective hoses immediately. Replace worn or broken hoses and fittings with factory replacement parts only.
Note: Do not use Teflon tread tape. Only use liquid type thread sealant.
3. To extend the life of the cylinder and hoses, store the machine under cover. If cover is not available, lubricate exposed cylinder rods with grease or remove the cylinder and hoses and store under cover.
4. Check tightness of lug bolts, spindle setscrews, rake wheel nuts, and all other capscrews, and nuts after one hour of operation and every 100 hours or 3 months of use thereafter (whichever comes first).
5. Replace any missing or broken parts.
6. Check tire pressure whenever maintenance is performed.
8. Repack transport wheel bearings at the beginning of each season or after every 50 hours of use.

Lubrication

The *RCR812* Hay Runner has Teflon coated bushings at the mainframe hinge, pivot hinge, rake arm hinge, transport hub, rake wheel hubs, tandem pins (optional), and center wheel pins (optional). Grease these points after every 50 hours of use. (See pictures below)



1. The rake wheel hubs have grease zerks and should be greased after every 50 hours of use.
2. Repack transport wheel hubs at the beginning of each season and grease after every 50 hours of use.

Tandem Axle Installation (Optional)

CAUTION! Wear proper protective equipment such as safety glasses and protective shoes when assembling.



The following instructions will guide you through the installation of the tandem axle. Tandem axles are optional and can be installed on any **RCR812** Hay Runner from the factory or after. The wheels on the tandem axle must be installed offset as shown with the front on the outside towards the rake wheels.

1. Start by attaching the rake to a tractor, unfolding the rake so the rake wheels rest on the ground and is most stable, then release hydraulic pressure.
2. Next jack up the rear of the rake under the main tube on the rear of the center weldment.
3. Remove the jam nut and set screw on the axle and slide the wheel assembly out.
4. Insert the 1/2" hex capscrew with the grease zerk into the welded square nut on the bottom side of the axle where the setscrew is removed.
5. Mount the tandem weldment (23) to the axle using the hinge pin (24). Clean and lubricate the hinge pins before installing. After installing the hinge pins, secure the pin using a 3/4" x 1-3/4" hex capscrew (28), SAE flatwasher (25), lockwasher (26), and hex nut (29). Attach the pin washer (21) using a 3/4" x 1-1/4" hex capscrew (28) and lockwasher (20).
6. Slide in the spindles (13) with the drilled indentation down so you can see when it appears through the welded nut (the backside of the spindle will be about flush with the tandem weldment).
7. Thread the 1/2" jam nut (17) on the 1/2" x 1-1/2" square head set screw (18) all the way up to the head of the setscrew. While making sure the spindle does not move, tighten down the spindle in the tandem weldment using the setscrews. Tighten the jam nut to ensure the set screw will not unthread. Mount tires and rims to hubs using lug bolts. Torque lug bolts to 75 ft-lbs.



Center Wheel Kit Installation (Optional)

CAUTION!



Wear proper protective equipment such as safety glasses and protective shoes when assembling.

The following instructions will guide you through the installation of the Center Wheel Kit. Center wheel kits are optional and can be installed on any *RCR812* Hay Runner as long as it had the tongue extension installed. For instructions installing a tongue extension refer to pages 5 and 10.

1. Start by attaching the rake to a tractor, unfolding the rake so the rake wheels rest on the ground and is most stable, then release hydraulic pressure.
2. Next mount the pivot plate (1) on the bottom side of the tongue extension using a quantity of 2 – 5/8” u bolts (5), 4 – lockwashers (6), and 4 – hex nuts (7). When mounting the plate, the end with the largest gap between the ear and the u bolt goes towards the front (refer to picture). Before tightening, slide the mount plate as far forward till the u bolt hits the weld on the tongue extension but stays straight perpendicular to the plate.
3. Insert the Left hand rake arm (8) in the front ears on the mount plate and the Right hand rake arm (10) in the back ears on the mount plate using the pivot pin (2), flatwasher (3), and a cotter pin (4). When inserting the pivots pins, the side with the welded anti-rotation collar should be facing the side that the rake wheel will be on for that particular rake. It should also be placed with the two bent ears on the collar facing up to slide around the ear on the mount plate.
4. Using a quantity of 2 – 5/8” u bolts (5), 4 – lockwashers (6), and 4 – hex nuts (7), install the cylinder mount plate (37) with the welded lug angling backward. Before tightening, adjust the cylinder mount plate so it measures 42-1/4” from the front of the pivot mount plate to the back of the cylinder mount plate.

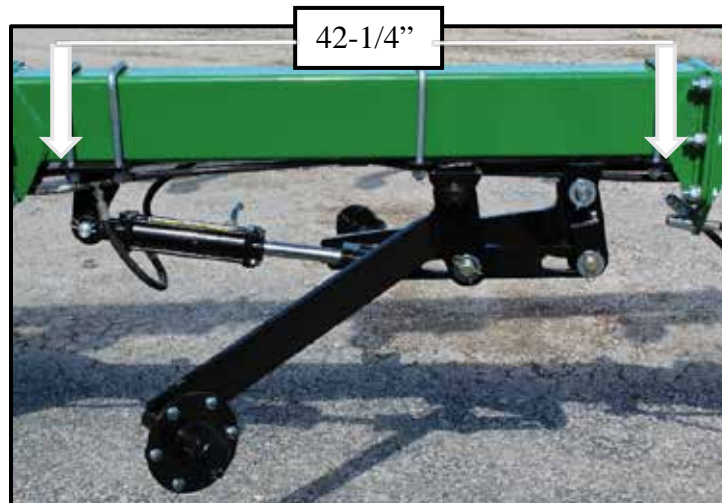

5. Install the cylinder (27) with the fittings coming out towards the left side of the rake using the pins that come with the cylinder and cotter pins (4) supplied. Extend the rod of the cylinder before connecting the hoses. The front fitting with the hand valve connects to the front “T” on the mainframe hydraulic hoses using the supplied hose (33). The rear fitting pointing down towards the ground wraps around the cylinder and connects to the rear “T” on the mainframe hydraulic hoses using the other supplied hose (33).



6. Bolt on each right and left hand 55” rake wheel with the 12 – hex flange nuts (15). The rake wheel labeled LH will go on the right side and the rake wheel labeled RH will go on the left side (this is opposite from the main rake wheels). Make sure that where the tines meet the ground they should be pointing forwards not backward.

7. Attach the linkage (9) to each rake arm between the main hole and the hole on the pin support that is welded on the back side. Use the 2 – pins (41) that come with clips and 4 – washers (3). Make sure the ends of the slots face upward like a smile (not a frown) so the rake wheels have the most amount of movement. Pin the linkage (9) into the end of the cylinder using the cylinder pin and a cotter pin (4) with the welded on spacer towards the left side and both slots forward.

CAUTION!



Always wear protective eye goggles and use a magnifying glass or use a piece of wood on suspected leaks. Pinhole hydraulic leaks can penetrate skin causing disease or death. Do not touch.

CAUTION!



Operate the hydraulic cylinders through the cycle a few times to expel all air from the system. Failure to fully charge the hydraulic system could result in injury or death when the rakes fall abruptly to the ground.

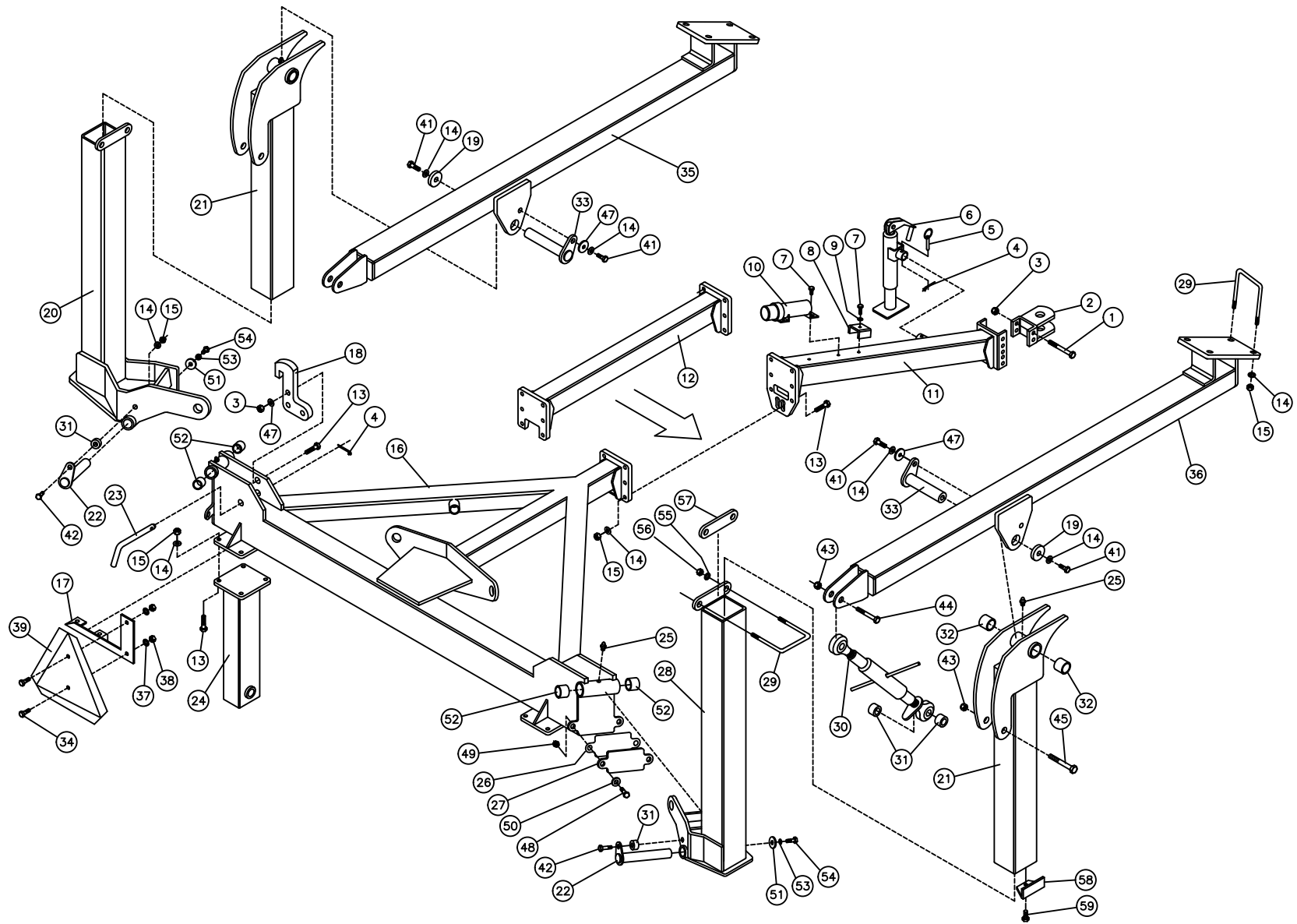

RCR812 Hay Runner Parts List

Number	Part Number	Description	Qty.
1	HRH587	Hex Capscrew, 5/8" x 7"	2
2	HR100	Clevis	1
3	HRH580	Nylock Hex Nut, 5/8"	2
4	0-56	Hairpin Clip, 2 15/16" x 5/32"	3
5	HP58-3	Pin, 5/8" x 3"	1
6	0-51	Jack Stand	1
7	K-326	Hex Capscrew, 3/8" x 1"	4
8	HR192	Hose Holder	2
9	K-308	Lockwasher, 3/8"	3
10	MH	Manual Holder	1
11	RCR11	Tongue Weldment	1
12	RCRT	Tongue Extension Weldment	1
13	0-156	Hex Capscrew, 5/8" x 2"	20
14	OE-155	Lockwasher, 5/8"	24
15	OE-154	Hex Nut, 5/8"	22
16	RCR16	Center Weldment	1
17	HR112	SMV Bracket	1
18	RCR18	Wing Transport Lock	2
19	HR190	Pin Retainer 1-1/4"	2
20	RCR20L	Wing Weldment (Left)	1
21	RCR21	Wing Extension Weldment	2
22	RCR22	Hinge Pin Weldment	2
23	H58-5B	Pin, 5/8" x 5" Bent	2
24	RCR15	Axle Weldment	2
25	VM-605	Grease Zerk, 1/4"	4
26	CRS16GA	Shim Plate	4
27	CRBP14	Bumper Plate	2
28	RCR20R	Wing Weldment (Right)	1

Number	Part Number	Description	Qty.
29	H34-4-534UB	U Bolt, 3/4" x 4" x 5-3/4"	6
30	TB22507	Turnbuckle	2
31	CR31	Bushing, 1" x 9/16"	6
32	VM-604	Flange Bushing, 1-1/4" x 1-1/4"	4
33	RCR33	Pivot Pin Weldment	2
34	K-334	Hex Capscrew, 1/4" x 1"	2
35	RCR35L	Lift Arm Weldment, Left	1
36	RCR35R	Lift Arm Weldment, Right	1
37	K-335	Lockwasher, 1/4"	2
38	K-336	Hex Nut, 1/4"	2
39	SMVS	SMV sign	1
41	H58-114	Hex Capscrew, 5/8" x 1-1/4"	2
42	HRH5825	Hex Capscrew, 5/8" x 2-1/2"	2
43	H34NL	Nylock Hex Nut, 3/4"	4
44	H34-4	Hex Capscrew, 3/4" x 4"	2
45	H34-5	Hex Capscrew, 3/4" x 5"	2
47	HRH58SF	Flatwasher, 5/8" SAE	2
48	H38-112	Hex Capscrew, 3/8" x 1-1/2"	4
49	HRH380	Nylock Hex Nut, 3/8"	4
50	H38FWUSS	Fender Washer, 3/8" USS	4
51	HR210	Pin Retainer, 1-3/4"	2
52	HRB175-150	Flange Busing 1-3/4" x 1-1/2"	4
53	H34LW	Lockwasher, 3/4"	12
54	H34-114	Hex Capscrew, 3/4" x 1-1/4"	2
55	H34W	Washer, 3/4"	4
56	CR20	Machine Nut, 3/4"	4
57	RCR57	U Bolt Spacer	2
58	CR22	Slide Plate	8
59	H12-1	Hex Capscrew, 1/2" x 1"	8

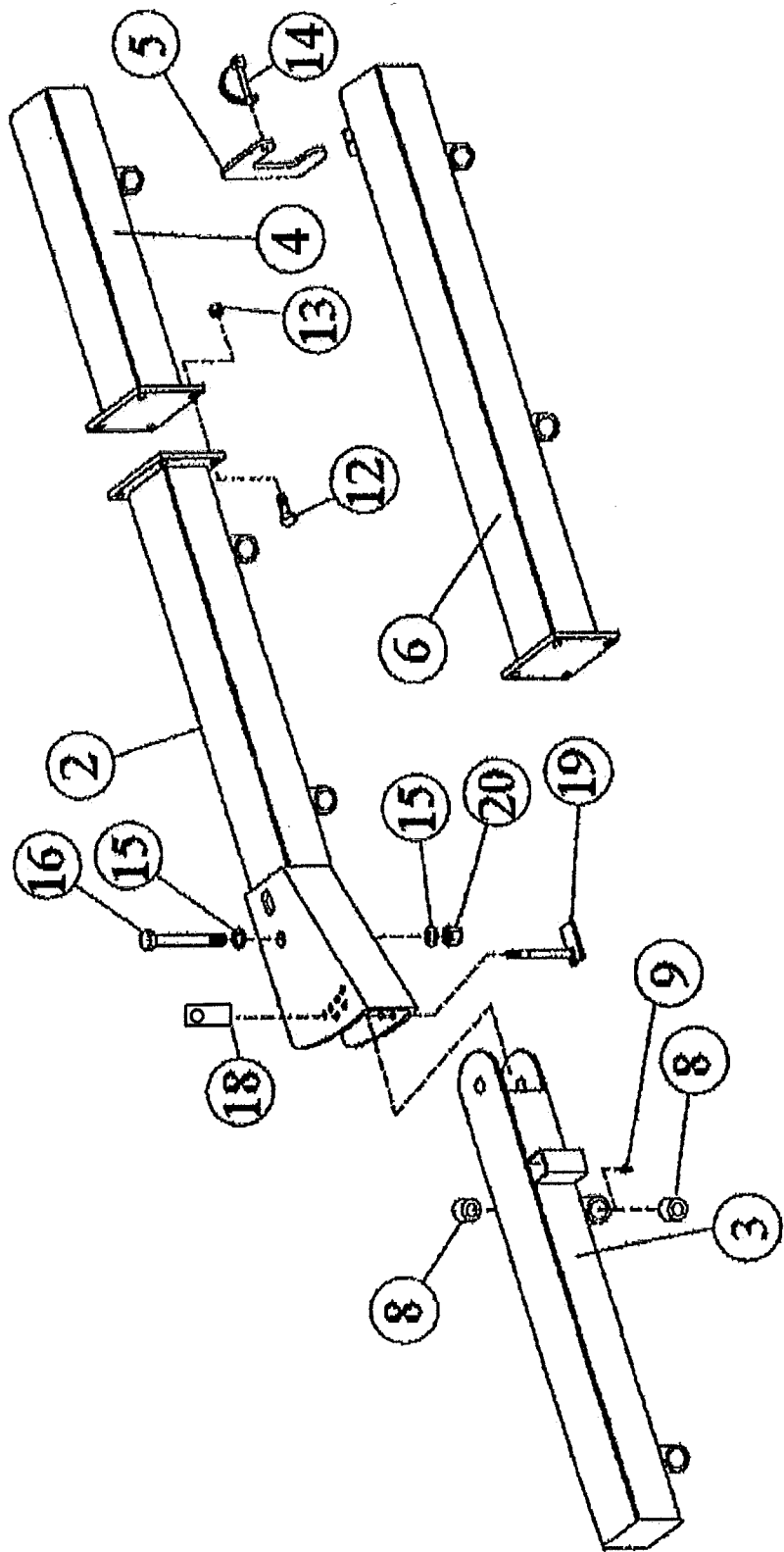

Hinged and Standard I-Series Assembly

Number	Part Number	Description
2	HR215	4 Wh I Series Front, RH
	HR217	4 Wh I Series Front, LH
3	HR216	4 Wh I Series Rear, RH
	HR218	4 Wh I Series Rear, LH
4	HR219	Single Rake Arm Extension, RH
	HR220	Single Rake Arm Extension, LH
5	HR224	Clip, Front Wheel
6	HR221	2Wh Rake Arm Extension, RH
	HR222	2Wh Rake Arm Extension, LH
8	HRB125	Bushing
9	VM-605	Grease Zerk, 1/4"
10	OE-154	Hex Nut, 5/8"
11	OE-155	Lockwasher, 5/8"
12	HRH12150-8	Hex Capscrew, 1/2" x 1 1/2" GR8
13	0-161	Nylock Nut, 1/2"
14	21992	Wirelock Pin, 3/8"
15	HRH58SF	SAE Flatwasher, 5/8"
16	HRH586	Hex Capscrew, 5/8" x 6"
18	CR21	Machine Nut 5/8"
19	HR223	Pin
20	HRH580	Nylock Nut, 5/8"

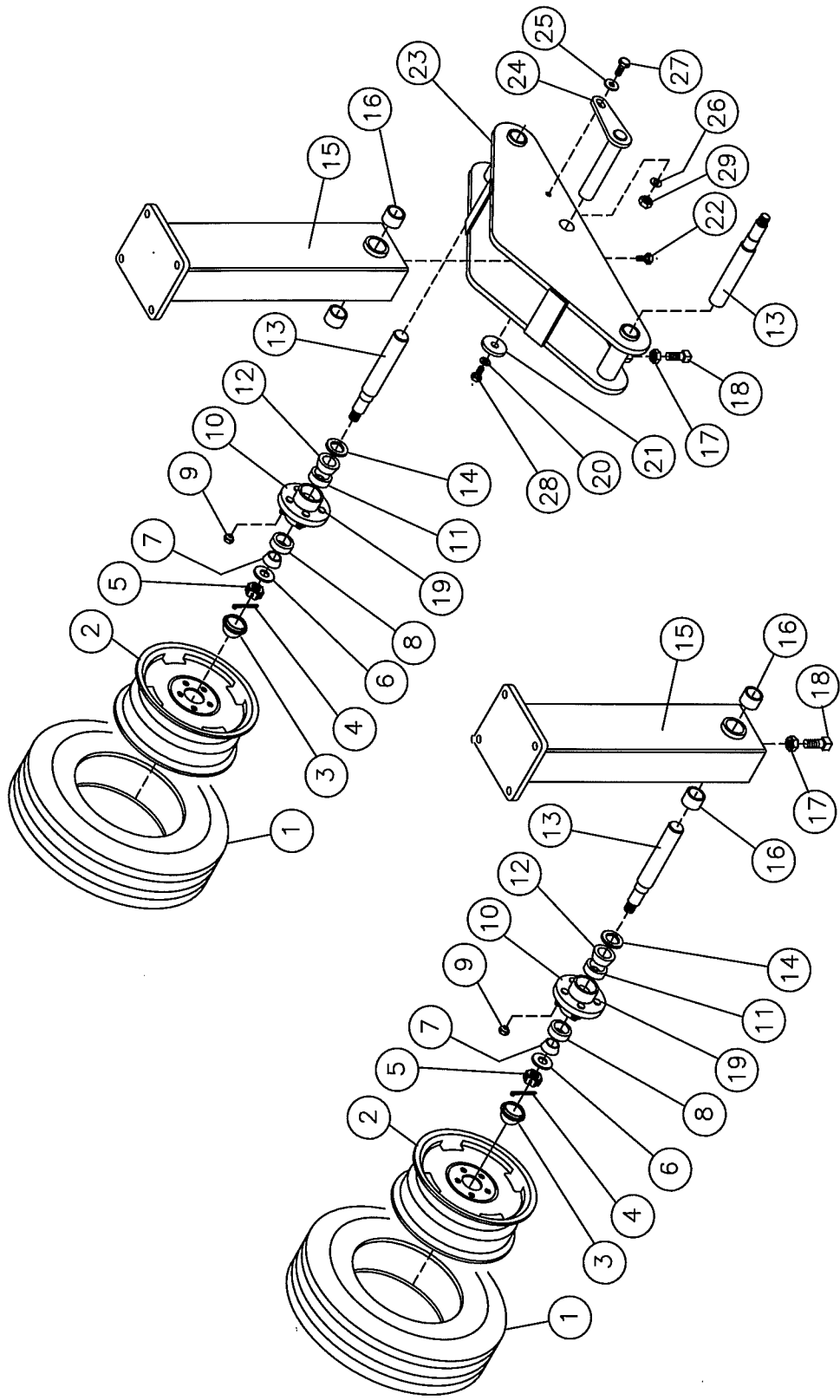

Axle Parts List

Number	Part Number	Description	Qty.
1	HR117	Tire	2
2	HR133	Wheel	2
3	909900	Dust Cap	2
4	905936	Cotter Pin	2
5	953005	Hex Castle Nut	2
6	951801	Flat Washer	2
7	910253	Outer Cone	2
8	910250	Outer Cup	2
9	912919	Wheel Nut, 1/2"-20	2
10	280090	Hub Complete	2
11	910251	Inner Cup	2
12	910252	Inner Cone	2
13	286929L14	Spindle	2
14	906281	Grease Seal	2
15	RCR15	Axle Weldment	2
16	HRB175-150	Bushing, 1-3/4" x 1-1/2"	4
17	0-179	Hex Jam Nut, 1/2"	2
18	0-178	Setscrew, 1/2" x 1-1/2"	2
19	953002	Wheel Stud, 1/2"-20 x 1-7/8"	10

Tandem Parts List

Number	Part Number	Description	Qty.
1	HR117	Tire	4
2	HR133	Wheel	4
3	909900	Dust Cap	4
4	905936	Cotter Pin	4
5	953005	Castle Nut	4
6	951801	Flat Washer	4
7	910253	Outer Cone	4
8	910250	Outer Cup	4
9	912919	Wheel Nut, 1/2"-20	4
10	280090	Hub Complete	4
11	910251	Inner Cup	4
12	910252	Inner Cone	4
13	286929L14	Spindle	4
14	906281	Grease Seal	4
15	RCR15	Axle Weldment	2
16	HRBF175-150	Bushing, 1-3/4" x 1-1/2"	4
17	0-179	Hex Jam Nut, 1/2"	4
18	0-178	Setscrew, 1/2" x 1-1/2"	4
19	953002	Wheel Stud, 1/2"-20 x 1-7/8"	20
20	H34LW	Lockwasher, 3/4"	2
21	HR210	Washer	2
22	GZB12-12	Grease Zerk Insert	2
23	CRTA1	Tandem Weldment	2
24	CRTA2	Pin Weldment	2
25	HRH58SF	Flat Washer, 5/8" SAE	2
26	OE-155	Lockwasher, 5/8"	2
27	HRH58175-8	Hex Capscrew, 5/8" x 1-3/4" GR8	2
28	HRH34125	Hex Capscrew, 3/4" x 1-1/4"	2
29	OE-154	Hex Nut, 5/8"	2

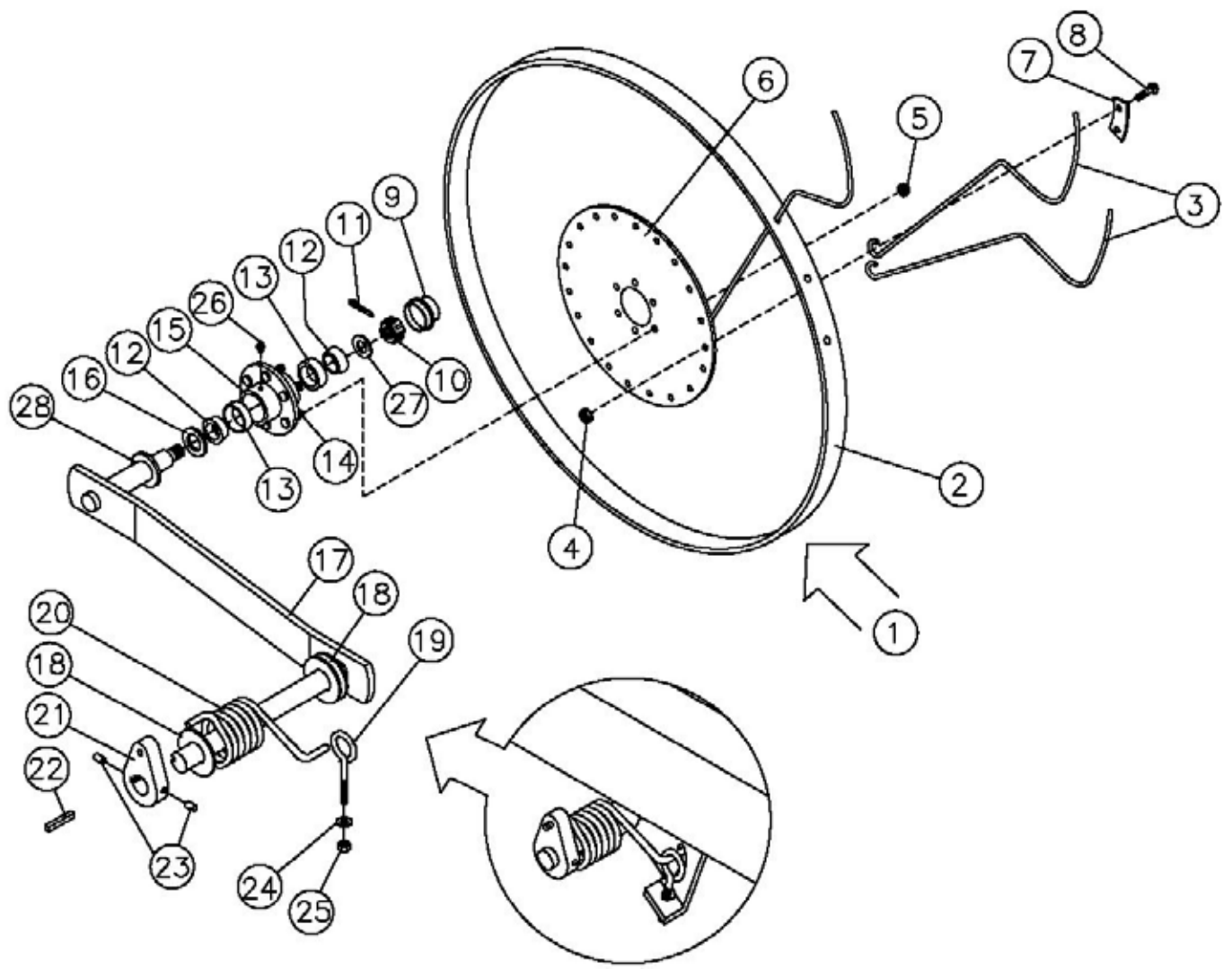

Rake Arm and Wheel Assembly

Number	Part Number	Description
1	HR118	Rake Wheel Complete, 55" RH
	HR119	Rake Wheel Complete, 55" LH
	RW60RH	Rake Wheel Complete, 60" RH
	RW60LH	Rake Wheel Complete, 60" LH
2	HR120	55" Rim
	RCROR	60" Outer Rim
3	HR121	Rake Tine, 7mm (55" wheel)
	RCRT	Rake Tine, 7.5mm (60" wheel)
4	HR122	Hex Nut, M10
5	HR123	Hex Flange Nut, 3/8"
6	HR124	Flange 55" Wheel
	RCR60F	Flange 60" Wheel
7	HR125	Tine Clamp
8	RP000369	Carriage Bolt, M10 x 25
9	909176	Hub Cap
10	953005	Hex Castle Nut, 1" -14
11	909454	Cotter Pin, .15" x 1.5"
12	910253	Bearing Cone, L44649
13	910250	Bearing Cup, L44610
14	3819	Stud 3/8"
15	105026C	Hub Complete
16	906282	Seal
17	HR150	Rake arm with welded in spindle/hub
18	VM-719	Machine Washer, 1-1/4" 18ga.
19	VM-609	Eye Bolt, 3/8" x 3-1/2"
20	VM-607	Torsion Spring, RH
	VM-608	Rorsion Spring, LH
21	HR152	Spring Block
22	HR151-2	Woodruff Key, 1/4" x 3/4"
23	VM-718	Set Screw, 3/8" x 1/2"
24	MCH38F	Flatwasher, 3/8"
26	M61	Grease Zerk, M6
27	913576	Washer
28	N807-P	Seal Protector

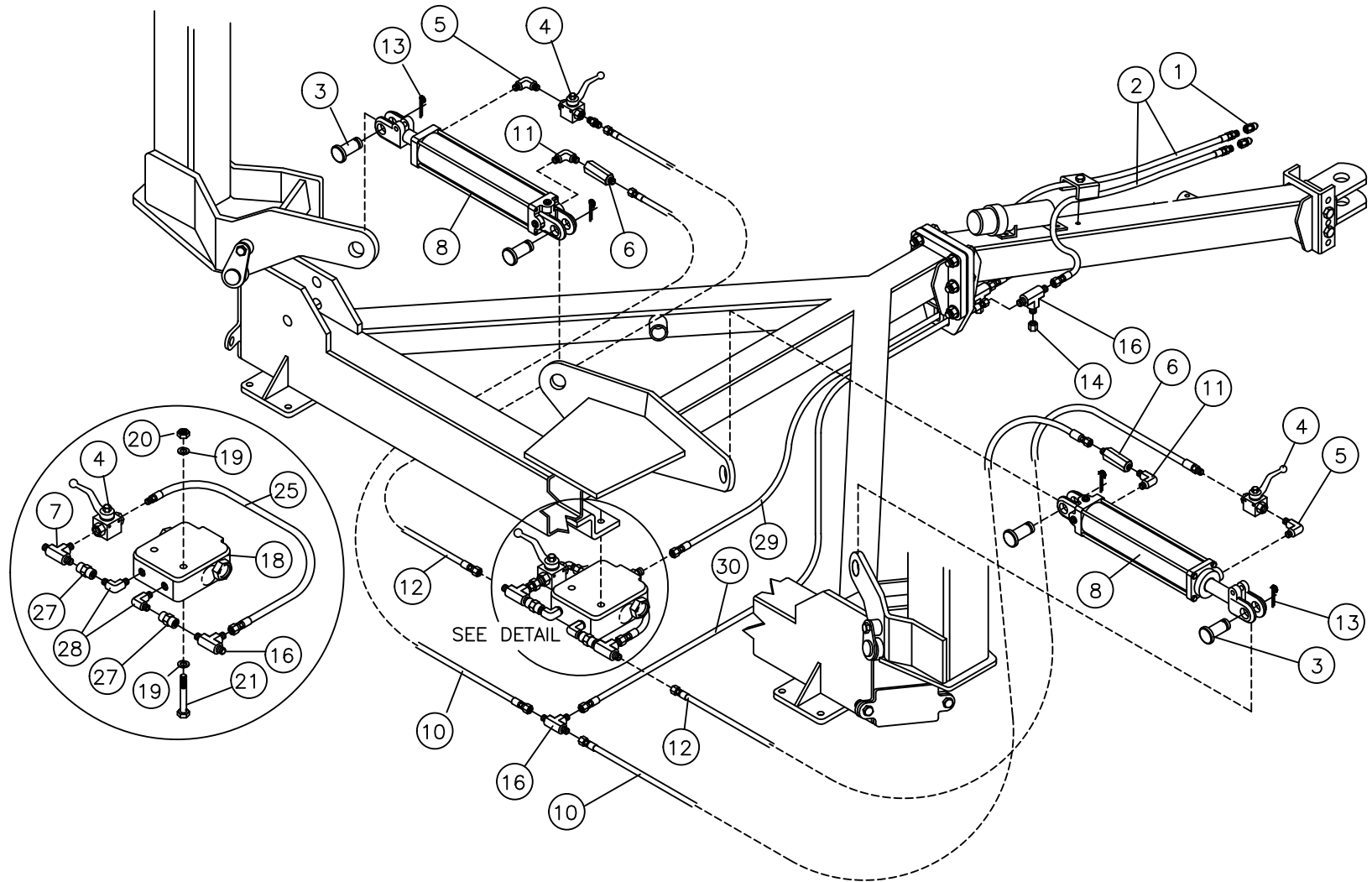

RCR812 Hay Runner Hydraulic Parts List

Number	Part Number	Description	Qty.
1	8010-15	Coupler, Male 8FB	2
2	CR201	Hose, 3/8" x 142" 8MB-8MJX	2
3	HR128	Cylinder Pin, 1" x 2-3/4"	4
4	WBV2-SAE8	Shut Off Valve, 1/2" 8MB	3
5	8MB-8MB90	Elbow, 90	2
6	PM-R-12	Restrictor	2
7	8MJ-8MJ-8MB	Tee	1
8	W3000120-S	Cylinder, 3" x 12" SAE8	2
	PMCK-300000	Seal Kit	
10	CR202	Hose, 3/8" x 20" 8MJX-8MP	2
11	8MB-8MP90	Elbow, 90	2
12	CR203	Hose, 3/8" x 25" 8MJX-8MB	2
13	CP316-214	Cotter Pin, 3/16" x 2 1/4"	4
14	8FJ-CAP	Cap	2
16	8MJ-TEE	Tee	3
18	HC-V-CB20	Flow Divider	1
19	FW14	Flatwasher, 1/4"	2
20	HRH140	Nylock Hex Nut, 1/4"	2
21	HRH143	Hex Capscrew, 1/4" x 3"	2
25	CR205	Hose, 3/8" x 20" 8MJX-8MB	1
27	8FJX-8MB	Fitting	2
28	8MB-8FB90	Elbow, 90	2
29	CR204	Hose, 3/8" x 62" 8MB-8MJX	1
30	CR206	Hose, 3/8" x 62" 8MJX-8MJX	1

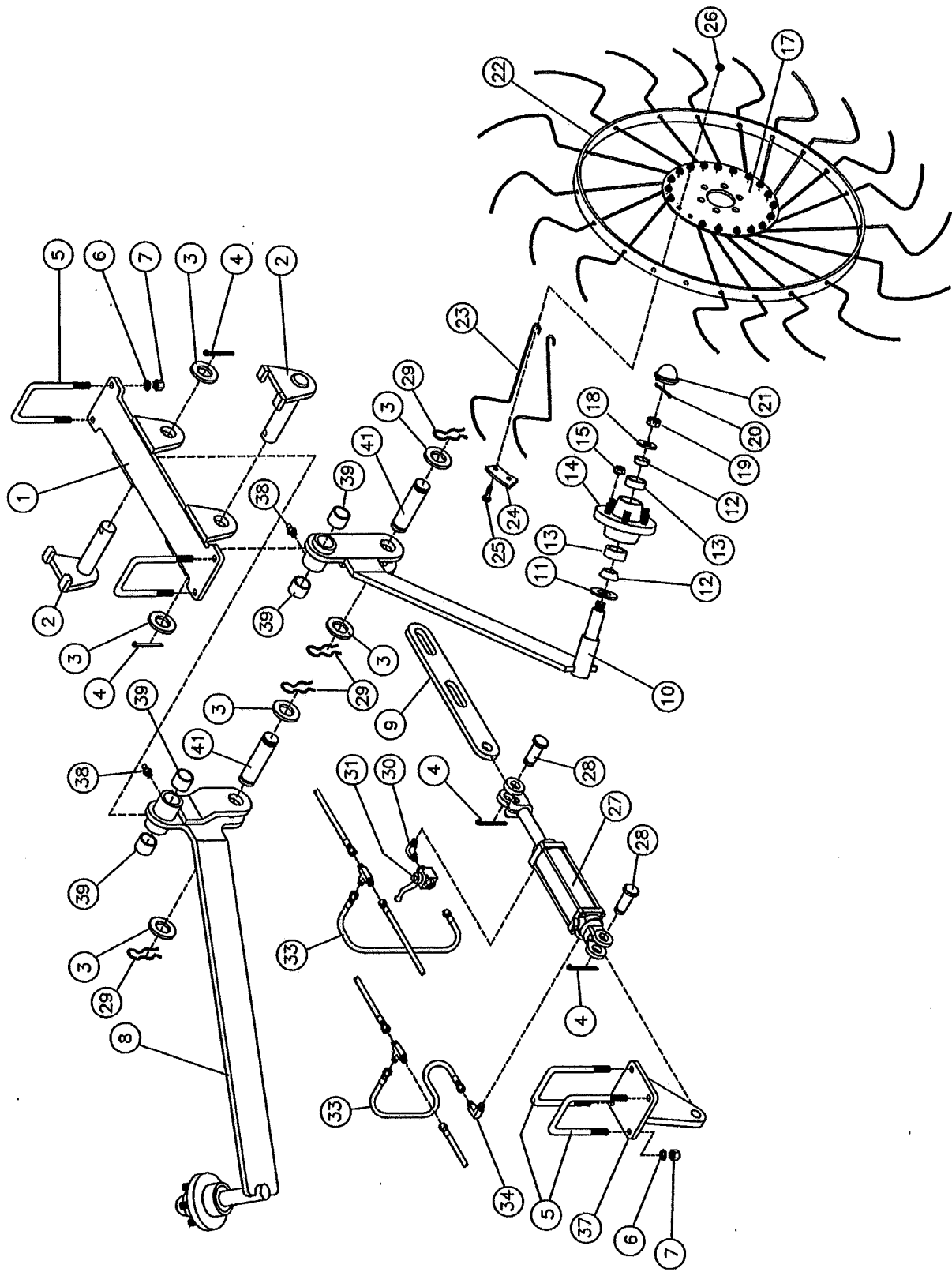

Center Wheel Kit Parts List

Number	Part Number	Description	Qty.
1	CR301	Mount Plate Weldment	1
2	CR302	Pivot Pin	2
3	H1FW	Washer, 1" SAE	6
4	CP316-2	Cotter Pin, 3/16" x 2"	4
5	H58-4-714UB	U Bolt, 5/8" x 4-1/16" x 7-1/4"	4
6	OE-155	Lockwasher, 5/8"	8
7	OE-154	Hex Nut, 5/8"	8
8	CR303L	Rake Arm (Left)	1
9	CR305	Linkage Arm	1
10	CR303R	Rake Arm (Right)	1
11	906282	Seal	2
12	910253	Bearing Cone, L44649	4
13	910250	Bearing Cup, L44610	4
14	105026C	Hub, complete	2
15	HR123	Hex Flange Nut, 3/8"	12
17	HR124	Flange	2
18	912576	Washer	2
19	953005	Hex Castle Nut, 1"	2
20	909454	Cotter Pin, .15" x 1.5"	2

Number	Part Number	Description	Qty.
21	909176	Hub Cap	2
22	HR118	Rake Wheel Complete, RH	1
	HR119	Rake Wheel Complete, LH	1
23	HR121	Rake Tine, 7mm	80
24	HR125	Tine Clamp	10
25	RP000369	Carriage Bolt, M10 x 25	20
26	HR122	Hex Nut, M10	20
27	W200060-S	Cylinder, 2" x 6" SAE6	1
	PMCK-W200000	Seal Kit	
28	HR128	Cylinder Pin, 1" x 2-3/4"	2
29	50892	External Clip	4
30	6MB-6MB90	Elbow, 90	1
31	WBV2-SAE6	Shut Off Valve, 3/8"	1
33	CR308	Hose, 3/8" x 18" 6MJX-6MB	2
34	6MB-6FB90	Elbow, 90	1
37	CR307	Cylinder Mount Weldment	1
38	VM-605	Grease Zerk, 1/4"	2
39	16TB16	Bushing, 1" x 1"	4
41	10200	Linkage Pin	2

Notes:



RCR812 Hay Runner Warranty Policy

Ogden Metalworks, Inc. warrants this product to be free from defects in material and/or workmanship under normal use and service for one year from the date of delivery by the dealer to the original purchaser. This warranty is only applicable if the unit is set up and operated as intended under normal service and in accordance with the instruction manual. Ogden Metalworks, Inc.'s obligation under this warranty is limited to the replacement of any part or parts which are determined defective by Ogden Metalworks, Inc. due to factory workmanship and/or material. Parts or components, if requested by Ogden Metalworks, Inc., must be returned through the selling dealer or distributor directly to Ogden Metalworks, Inc. with all transportation charges prepaid, for inspection and determination of warranty. This warranty does not cover common wear items or component parts not manufactured by Ogden Metalworks except to the extent of their manufacturer's warranties. This warranty does not cover, under any circumstances, any parts, components, or materials which have been subjected to neglect, misuse, alteration, accident or if repaired with parts other than those manufactured by and obtained from Ogden Metalworks, Inc. Credit for required labor will be issued at the company's discretion.

This warranty is extended solely to the original purchaser and is not transferable. This warranty is not valid unless the warranty card has been returned to Ogden Metalworks, Inc. within 30 days from the date of purchase by the end user.

Ogden Metalworks, Inc.

Ogden Metalworks, Inc. reserves the right to change specifications and dimensions without notice.

Warranty will not be valid unless card is returned

RCR812 Hay Runner Warranty Card

Please print Purchased Date _____

Name _____

Address _____

Address _____

Serial Number _____ Model _____

Dealer _____

Address _____

