

AGRICULTURAL MACHINERY

sitrex®
Spa

**ASSEMBLY, USE AND MAINTENANCE
SPARE PARTS LIST**

RT/5800-H

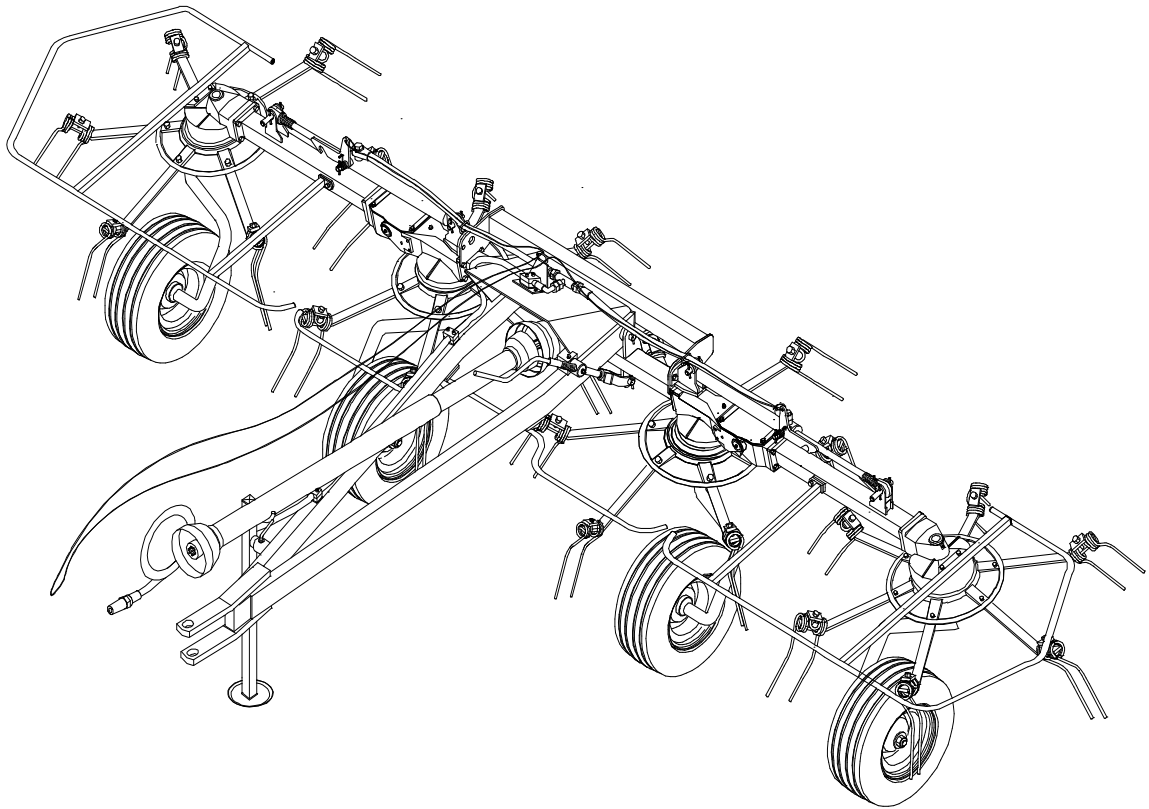

ROTARY TEDDER

10/06

WARRANTY

On delivery, check that the machine has not been damaged during transport and that all the attachments are present. Claims must be made in writing to the agent within 8 days of receipt.

The manufacturer warrants new machinery at the time of delivery to the original purchaser to be free from defects in material and workmanship if properly set up and operated in accordance with this Operator's Manual.

The manufacturer undertakes to repair or replace free of charge any defective part which should be returned by the purchaser (freight prepaid) and found to be defective by inspection authorized by the manufacturer during the warranty period.

This warranty will be valid for 12 (twelve) months from the delivery of goods to the original purchaser .

In case the customer is not in a position to return the defective part to the manufacturer , the manufacturer cannot be held responsible for any cost due for repair or replacement of any part of the machine , he will only supply the part(s) required for the repair and/or replacement.

The warranty is null and void when it is evident that the machine has been improperly used or however repaired without authorization.

The manufacturer undertakes no responsibility for any obligation or agreement reached by any employers, agents or dealers, which are not in compliance with the above warranty . The manufacturer cannot be held responsible for the consequent damages. This warranty substitutes any other warranty , express or implied , and any other manufacturer's obligation.

CHAPTER

- 1) GUIDE TO THE SIGNS**
- 2) General summary of safety and accident-prevention instructions**
- 3) PRODUCT IDENTIFICATION**
- 4) DELIVERY AND ASSEMBLY**
- 5) ADJUSTMENT, PREPARATION AND USE**
- 6) MAINTENANCE**
- 7) SPARE PARTS LIST**

1) GUIDE TO THE SIGNS AND SYMBOLS USED ON THE MACHINE

IMPORTANT

These signs and symbols give information to the operator on how to make the best use of the machine so as to prolong life, avoid damage, optimise work and, above all, to avoid injury to the operator and anyone within range of the machine.

WARNING SIGNS

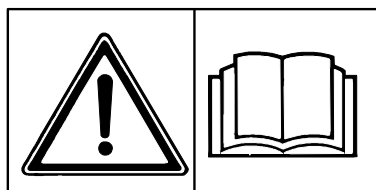

1) Before beginning operations, read the instruction manual carefully.

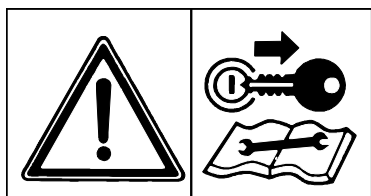

2) Before doing any maintenance or repair work, stop the machine at a suitable spot. Turn off the tractor motor, apply the brake, remove the key from the ignition and consult this manual.

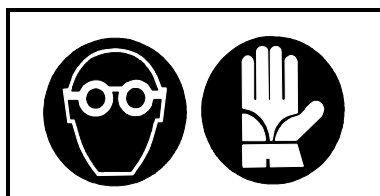

3) This is a warning to use proper accident protection when carrying out maintenance and repairs

DANGER SIGNS

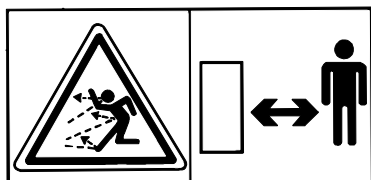

4) Risk of possible ejection of blunt objects. Keep a safe distance from the machine

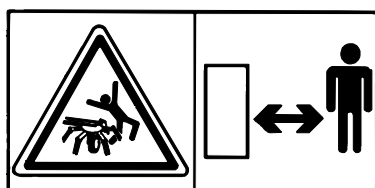

5) Indicates that anyone coming within range of the moving tine arms will be seriously injured. Keep a safe distance from the machine.



6) Indicates that there is a risk of crushing your hands. Keep your distance.

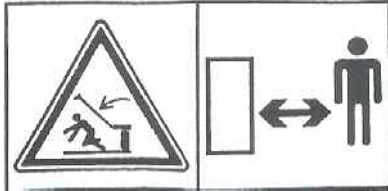

7) Indicates danger caused by accidental fall of suspended arms. Keep safe distance.



8) Indicates that it is dangerous to touch the cardan (P.T.O.) shaft.

For all the other information regarding the cardan shaft, see the use and maintenance booklet specifically for the cardan shaft which, together with this manual, makes up the documentation on safety, use and maintenance of the machine.

INDICATION SIGNS



9) Indicates a greasing point.



10) Shows the direction of rotation of the power takeoff and the maximum number revolutions.

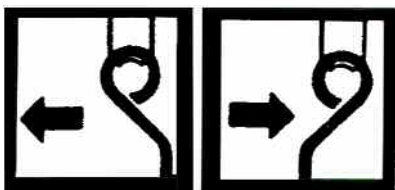

11) Indicates position of the tines on the rotors and their direction of rotation.

GENERAL SUMMARY OF SAFETY AND ACCIDENT PREVENTION INSTRUCTIONS

Read all the instructions carefully before using the machine. When in doubt seek advice from the manufacturing company.

The manufacturing company declines all responsibility for non-compliance with the following safety and accident prevention instructions.

1. Pay attention to the danger signs and symbols in this manual and on the machine.
2. Do not touch moving parts.
3. All work on the machine (including adjustments) must always be carried out with the tractor immobilised and the engine switched off.
4. On no account may persons or animals be carried on the machine.
5. Driving the tractor with the machine connected is absolutely forbidden to persons lacking suitable experience, or who are in poor health, or who are too young or do not have a suitable driving licence if travelling on the highway.
6. All accident prevention measures recommended in this manual should be scrupulously observed.
7. Connecting the machine to the tractor creates a different weight distribution on the tractor axles and so it is essential to ensure that the tractor-machine combination is stable in all anticipated working condition. It is therefore necessary to have exact instructions from the tractor manufacturers. If such instructions are not available, suitable tests should be conducted in safe conditions in order to assess stability.
8. Once the machine is connected it can only be controlled through a Cardan (P.T.O.) shaft complete with the required overload protection and guard secured with the appropriate small chains. Be aware of the rotational direction of the Cardan (P.T.O.) shaft.
9. Before operating the tractor and machine, check that all transport and operational safety devices are complete and working.
10. When driving on public roads, you should comply with the highway code regulations for the country concerned.
11. Do not exceed the tractor axle maximum weight and the total mobile weight.
12. Before starting work, familiarise yourself with the control devices and how they work.
13. Wear suitable clothes. Do not wear clothing which is loose or which could become entangled in rotating or moving parts.
14. Connect the machine to a suitably powerful tractor by using an appropriate lifting unit and in accordance with instructions.
15. Take maximum care when connecting and disconnecting the machine to and from the tractor.

16. The machine and any road transport attachments must bear the appropriate signs and symbols and have suitable protection.
17. Never leave the driving seat when the tractor is running.
18. It is extremely important to appreciate that road-holding, steering and braking may be significantly affected with the machine attached.
19. When turning corners with the machine attached, be aware of the fact that the centrifugal force will alter due to the change in the centre of gravity.
20. Before engaging the power takeoff, check the pre-set revolution speed, **MAXIMUM 540rpm.** Do not use 1000rpm drive.
21. Under no circumstances should anybody stand near the machine or any moving parts. It is the duty of the operator to ensure that this requirement is respected.
22. Before leaving the tractor, lower the machine with the lifting unit, stop the engine, apply the parking brake and remove the ignition key from the instrument panel.
23. Under no circumstances should anybody go between the tractor and the machine (Fig.1) when the engine is running and the Cardan (P.T.O.) shaft is engaged, especially without first having applied the parking brake and placed chocks against the wheels.
24. Before connecting or disconnecting the machine to or from the 3-point linkage, put the lifting unit lever into the locked position.
25. The connection pins on the machine must match the connection sockets on the lifting unit.
26. During transport, stop machine sway, secure the lower lift arms with the stabilisers or check chains.
27. When the machine is raised during road transport, put the tractor's hydraulic lift control lever into the locked position.
28. Only use the Cardan (P.T.O.) shaft provided by the manufacturer and, in case of replacement, substitute it with one having the same characteristics.
29. Regularly check all protection guards on the Cardan (P.T.O.) shaft. These should always be in excellent condition and securely fixed.
30. It is important to ensure that the protection on the Cardan (P.T.O.) shaft is complete.
31. Connection and disconnection of the Cardan (P.T.O.) shaft must be carried out with the engine stopped and switched off.
32. Pay particular attention to the correct connection and safety of the Cardan (P.T.O.) shaft and the power takeoffs on the machine and the tractor.

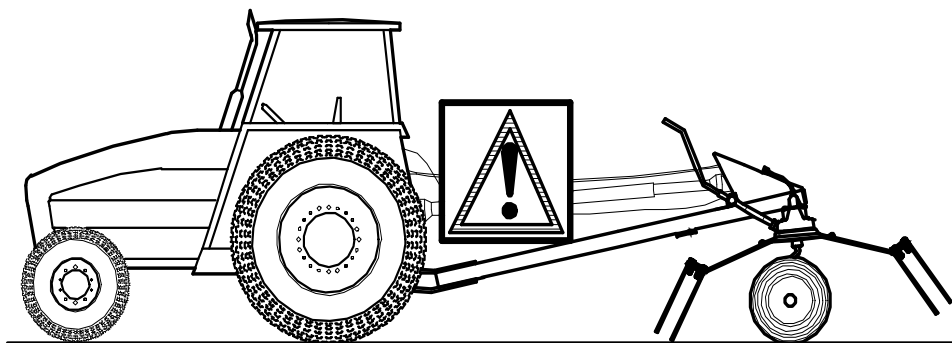

- 33. Prevent the Cardan (P.T.O.) shaft protection from rotating using the chains supplied.
- 34. Before engaging the power takeoff, make sure that there are no people or animals in the vicinity and that the selected engine speed corresponds to the Cardan (P.T.O.) speed permitted. 540rpm **MAXIMUM**.
- 35. Do not engage the power take-off when the engine is not running.
- 36. Always disengage the power take-off when the Cardan (P.T.O.) shaft is at too wide an angle (it should never be more than 35° - Fig.2) and when it is not in use.

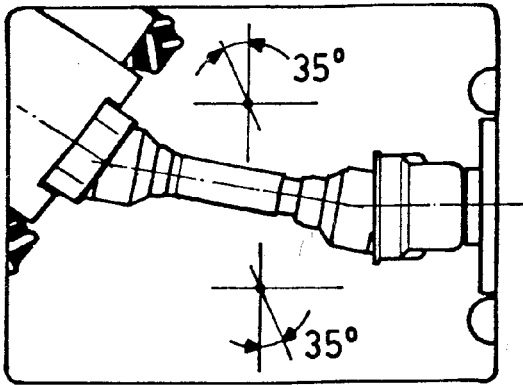
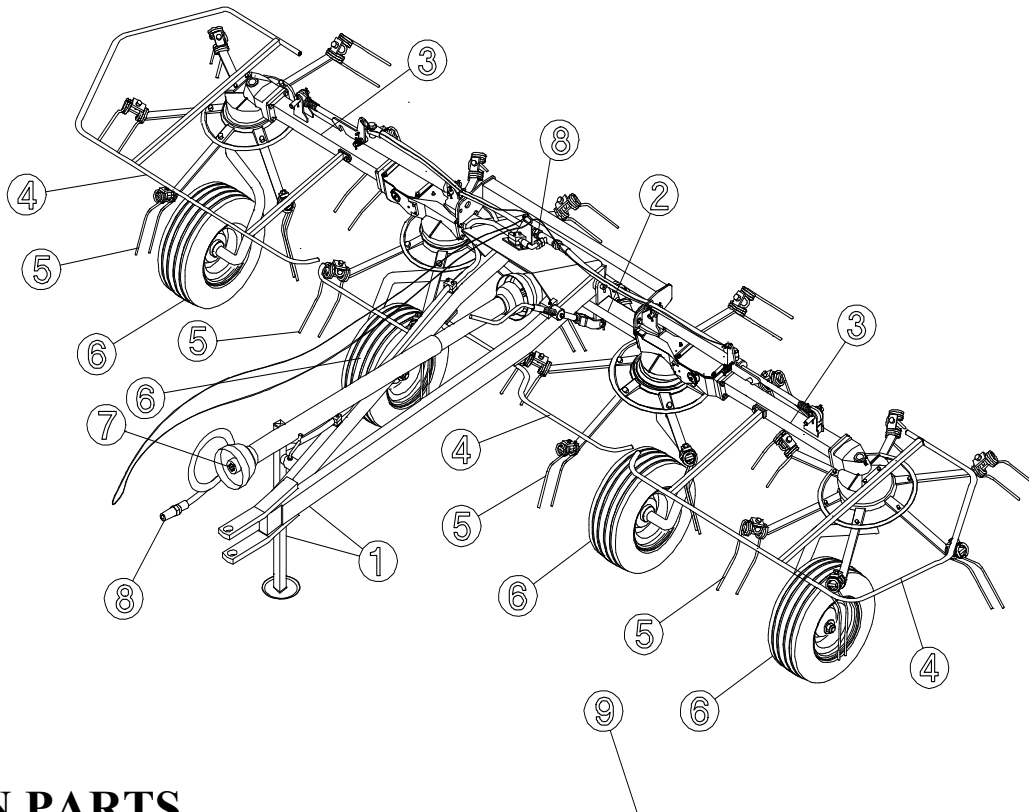

FIG.2

- 37. Only clean and grease the Cardan (P.T.O.) shaft when the power takeoff is disengaged, the engine is off, the parking brake is applied and the ignition key is removed.
- 38. When the Cardan (P.T.O.) shaft is not in use, rest it on the support provided.
- 39. On disconnecting the Cardan (P.T.O.) shaft, replace the protective cover on the power input (gearbox) shaft.

- 40. Prolonged use of the machine can cause the drive boxes (Fig.4) to become hot. To avoid any risk of getting burnt, avoid touching these areas both during use and some time afterwards.
- 41. Periodically check screws and nuts for tightness and grip. Tighten as necessary.
- 42. When the machine is raised for maintenance work and tine replacement, put suitable supports under the machine as a safety precaution.
- 43. Ensure that the recommended grease is used.
- 44. Spare parts must meet the requirements as defined by the manufacturer. Use only original spare parts.
- 45. Safety decals must always be clearly visible. They must be kept clean and replaced if they become too illegible (they can be ordered from the dealer if necessary).
- 46. The instruction booklet must be available to all users for the lifetime of the machine.

3) PRODUCT IDENTIFICATION



MAIN PARTS

- 1) DRAWBAR AND PARKING STAND
- 2) MACHINE BODY
- 3) RH AND LH LATERAL ROTORS
- 4) RH, CENTER AND LH GUARD
- 5) RH AND LH TINE ARM
- 6) WHEEL ASSEMBLY
- 7) CARDAN SHAFT
- 8) HYDRAULIC KIT
- 9) IDENTIFICATION PLATE



TECHNICAL DATA

SPECIFICATIONS	RT/5800-H Hydraulic fold
Number of rotors	4
Tine arms per rotor	6
Working width	19' (5,80 m)
Transport width	11' (3,35 m)
Weight	1225 lbs (555 kg)
Tire	16x6.50-8
PTO Tractor requirement	25 hp (18 kw)
PTO slip clutch	Standard
Operating speed	10 mph (16 Km/h)

All data are indicative. Sitrex reserves the right to change them without advance notice.

4) DELIVERY AND ASSEMBLY

Checking the machine on delivery

All parts are carefully checked before dispatch or delivery.

On receiving the machine, ensure that it has not been damaged during transport. If damage has occurred, contact the dealer concerned.

Details of packing are given below.

UNPACKING THE MACHINE



DANGER !!!



Lift the machine using a forklift truck, crane or other suitable equipment of sufficient capacity after first checking the weight of the configurations in the table given below.

Check the stability and positioning of the load on the forklift truck forks or crane hook.

Keep the load as low as possible during movement for maximum stability and to ensure that the operator has maximum visibility.

If a forklift truck is used, ensure that the forks are positioned as wide apart as possible.

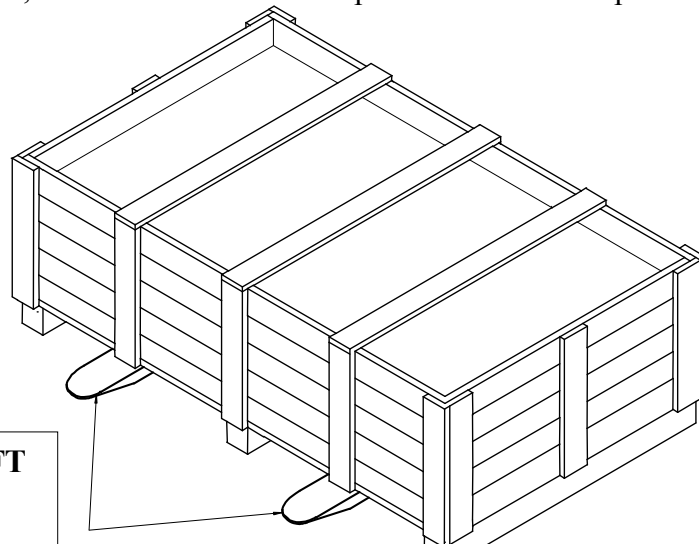

**FORKLIFT
LIFTING
POINTS**

MACHINE	WEIGHT PACKING KG/LBS	WEIGHT KG/LBS
RT/5800-H	620/1365	555/1225
****	*****	****

NOTE:

1) The packing consists mainly of wood, which should be disposed of according to the laws in force in the country where the machine is used.

The plastic film should also be disposed of according to the laws in force in the country where the machine is used.

2) When storing, it is permissible to stack 2-3 crates on top of each other. Make sure that they are perfectly aligned cortically.

3) In the event of further transport, ensure that the machine when on the transporting vehicle.

ASSEMBLY INSTRUCTIONS

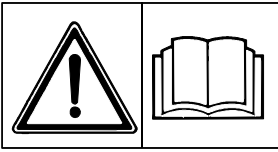

DANGER !!!



Assembly is highly dangerous and must be carried out in strict accordance with the following instructions. We recommend that qualified personnel perform assembly. We also recommend that assembly be carried out in a flat, solid surface, open area with no people (particularly children) nearby who could be severely injured if they were to touch or move any parts of the machine.

Assemblers must provide suitable lifting mechanisms and supports for stabilizing the partially assembled units, so as to prevent them from falling and causing damage or injury. The steps for assembly are illustrated in following. Depending on the experience of the assemblers and the tools available, it is not necessary that the instructions be followed in the exact order given here, but the safety precautions described above must always be followed carefully and scrupulously.

ASSEMBLY SEQUENCE:

SUPPORTS AND WHEELS ASSEMBLY

1) To facilitate the assembly of the wheel supports, we advise that you turn the machine body upside-down. If you choose to use a different assembly To method, bear mind that once pins 5 and bushings 6 (pre-assembled by us in the shop to guarantee correct assembly and safe handling of the machine) are removed, the rotor assemblies 1-2-3-4 are free to move from their mounting, causing problems both for correct assembly and for the safety of the operators.

USE MAXIMUM CAUTION.

2) See fig.”A”) Remove pins 5 and bushings 6 (keep in mind the warnings in step 1).

3) To avoid errors in assembly, we have numbered both the wheel supports 1-2-3-4 and the rotor assemblies 1-2-3-4 with sthickers. Therefore, one need simply combine the wheel support marked “1”, and so on.

4) Before moving on to the fastening of wheel supports 1-2-3-4 to the respective rotors, make sure that the position of holes A-B-C-D of the rotor disks are positioned as shown.

5) (See fig.”B”) Now fasten wheel supports 1-2-3-4 using spring pins 5-7.

6) (See fig.”C”) Attach the large hay guards 7 to wheel supports 1-2-3-4, followed by wheels 8, small hay guards 9, washers 10 and fasten with nuts 11.

In this steps, you will use:

Item 5: 4 spring pins $\varnothing 10 \times 55$ (0.39” x 2.17”)

Item 7: 4 spring pins $\varnothing 6 \times 55$ (0.24” x 2.17”)

Item 10: 4 flat washers $\varnothing 17$ (0.67”)

Item 11: 4 nuts M16

NOTE: At this point the tine arms could be attached because the machine is in a favorable position, but once the arms are attached it is more difficult to turn the machine over. If the assembler wishes to attach them at this stage, see pages 15-16 step “E”.

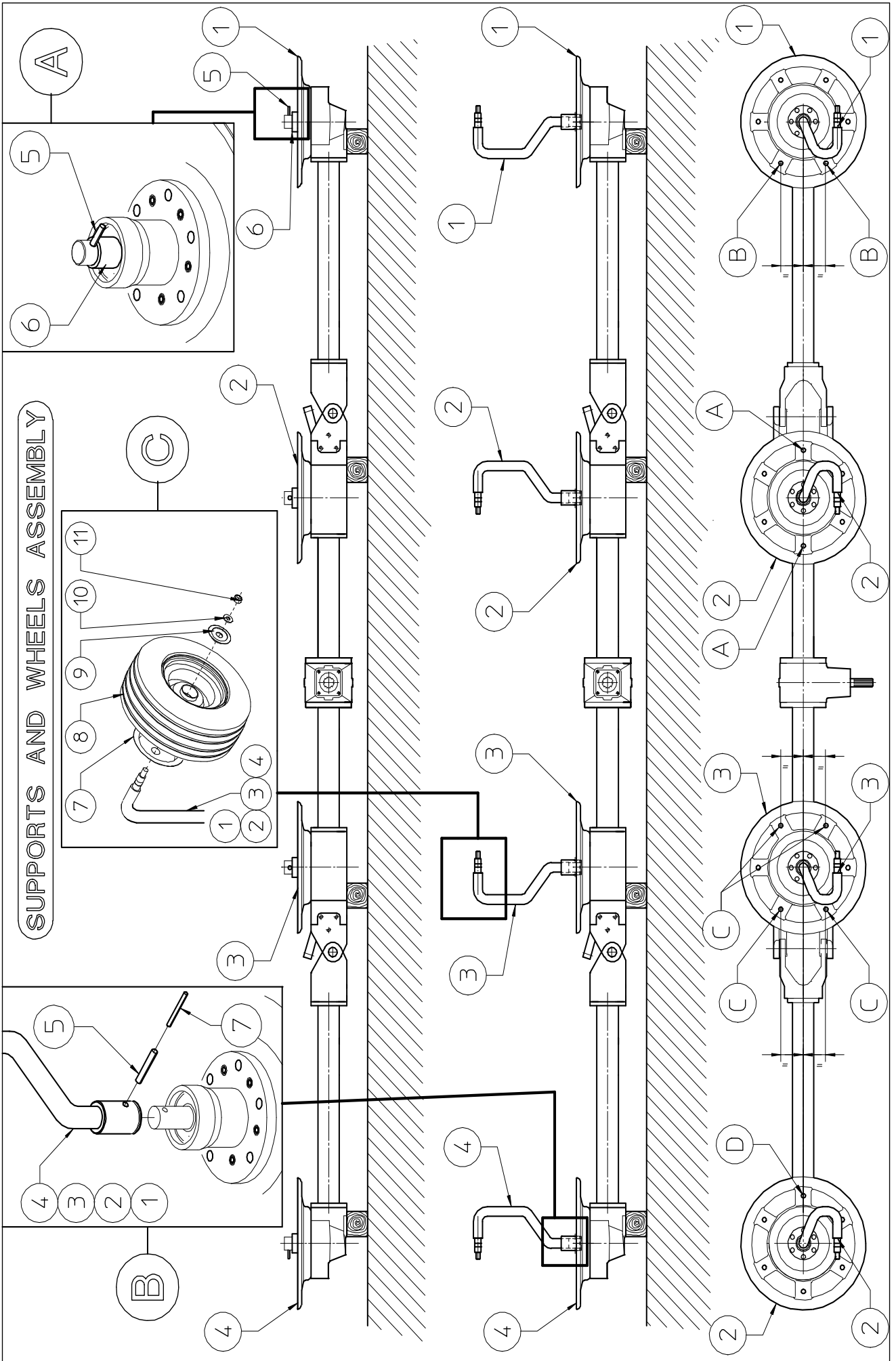

ASSEMBLING STEPS

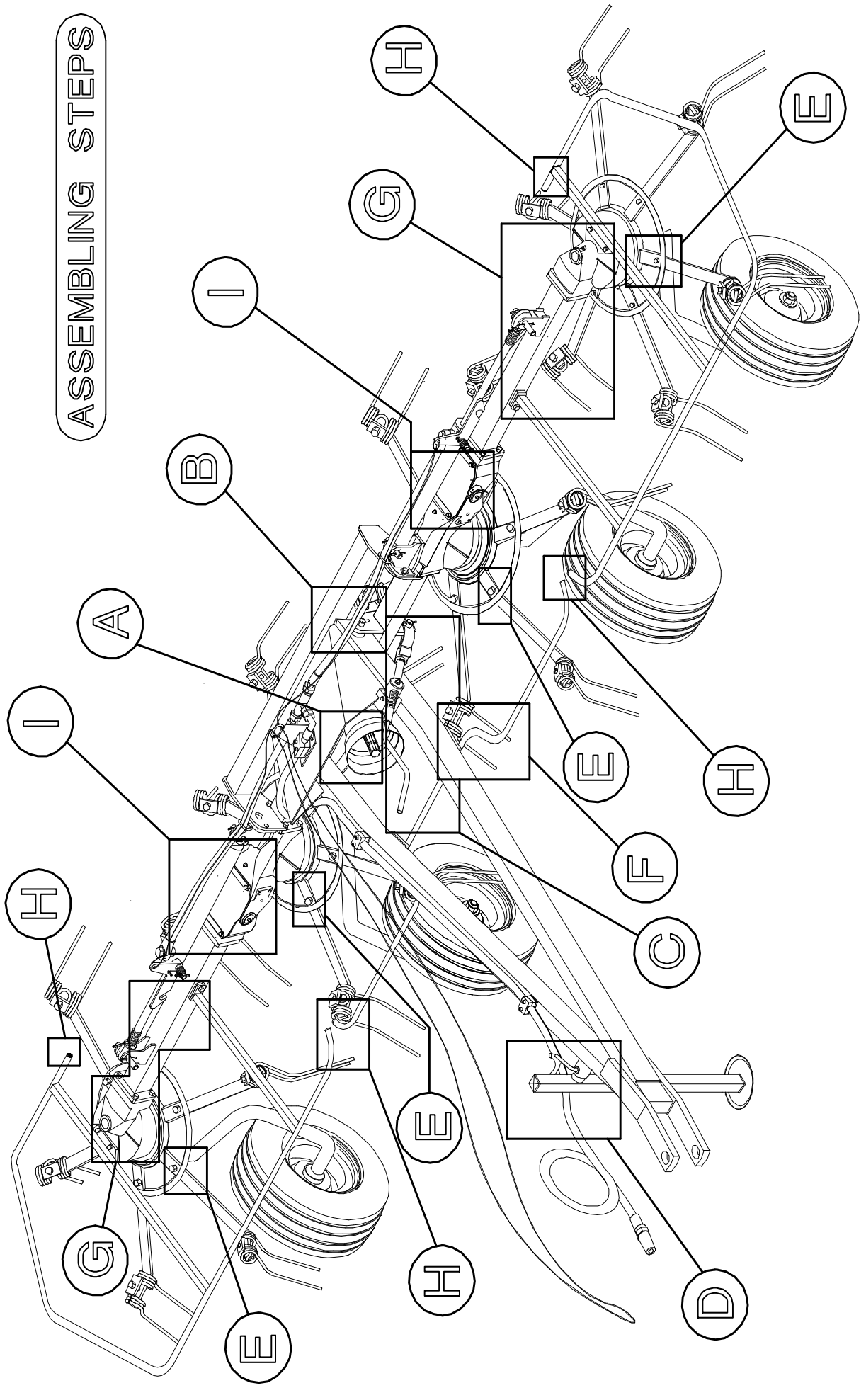

STEP "A"

Attach grease nipple 4 to the central gear box 2.

Attach guard 1 to the central gear box 2 using nuts 3

In this step, you will use:

Item 3 : 2 nuts M8

Item 4 : 1 grease nipple M6

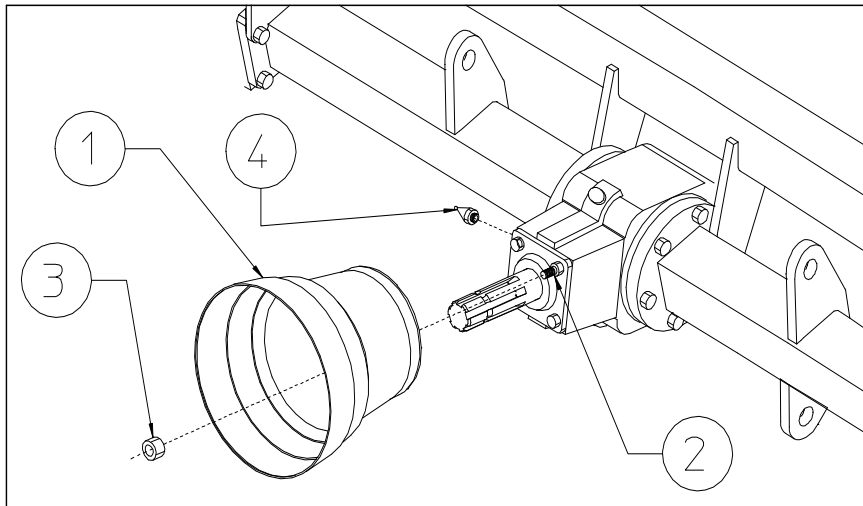

STEP "B"

Attach drawbar 1 to the machine body 2 with pin 3 into the holes 5 of the machine body 2 and drawbar 1 (passing pin 3 through hole 4 of the machine body 2). Fasten pin 3 with split pins 6.

In this step, you will use:

Item 6 : 2 split pins $\varnothing 5 \times 40$ ($\varnothing 0.2'' \times 1.57''$)

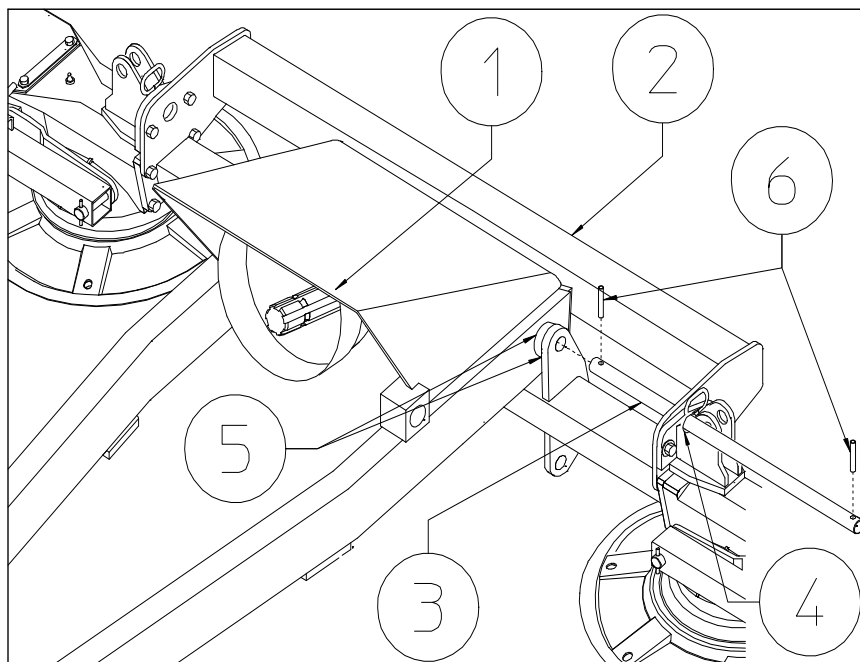

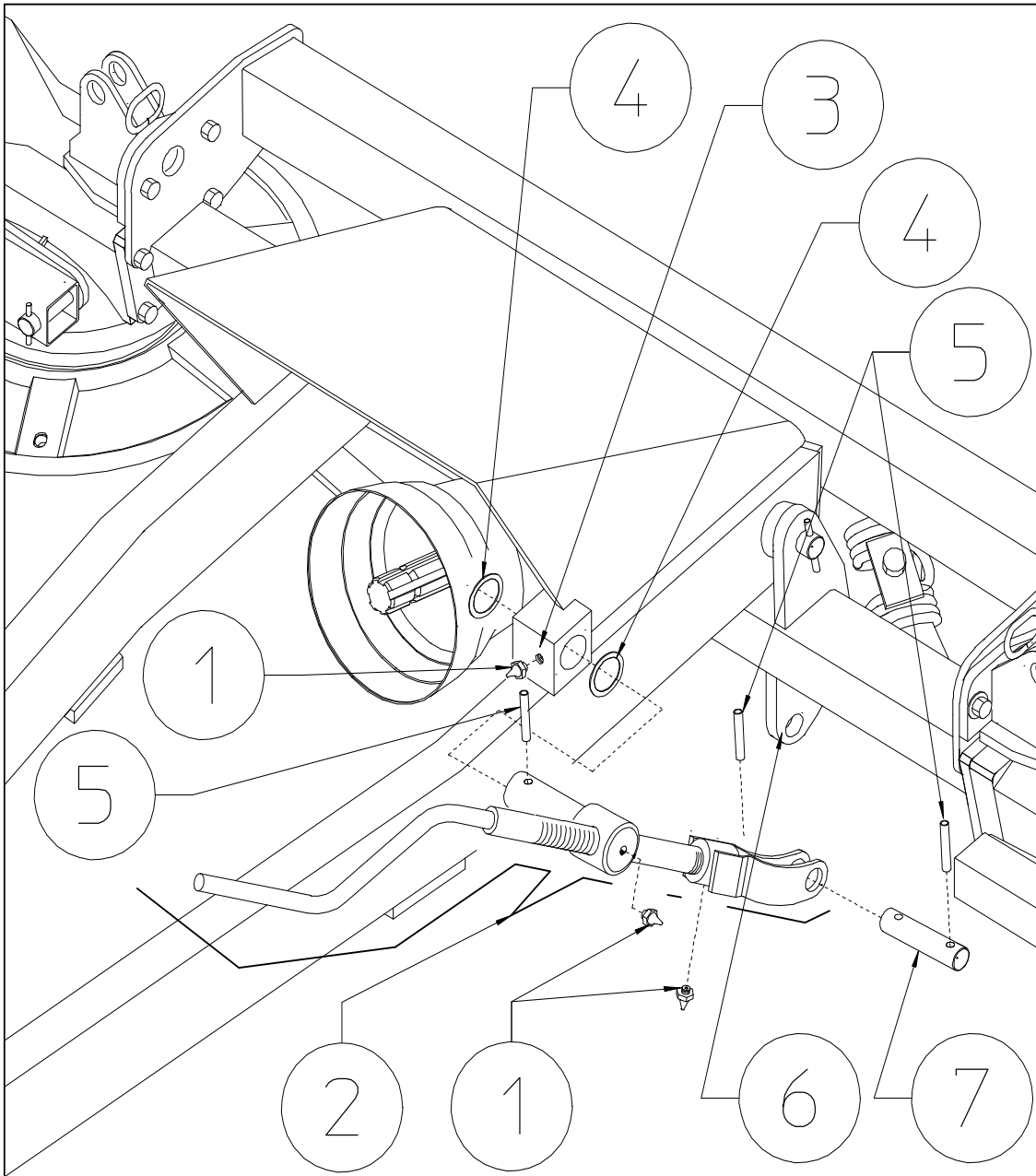

STEP “C”

Attach grease nipples 1 to the pin and fork of the crank assembly 2. Insert the pin of crank assembly 2 into its seat in drawbar 3, inserting the spacers 4. Fasten in place with split pin 5. Fasten the fork of the crank assembly 2 at hole 6 using pin 7 and split pins 5.

In this step, you will use:

Item 1 : 3 grease nipples M6

Item 4 : 2 shims $\varnothing 30.5 \times 39.8 \times 1$ ($\varnothing 1.2'' \times 1.57'' \times 0.04''$)

Item 5 : 3 split pins $\varnothing 5 \times 40$ ($\varnothing 0.2'' \times 1.57''$)

Item 7 : 1 pin $\varnothing 20 \times 66$ ($\varnothing 0.79'' \times 2.6''$)

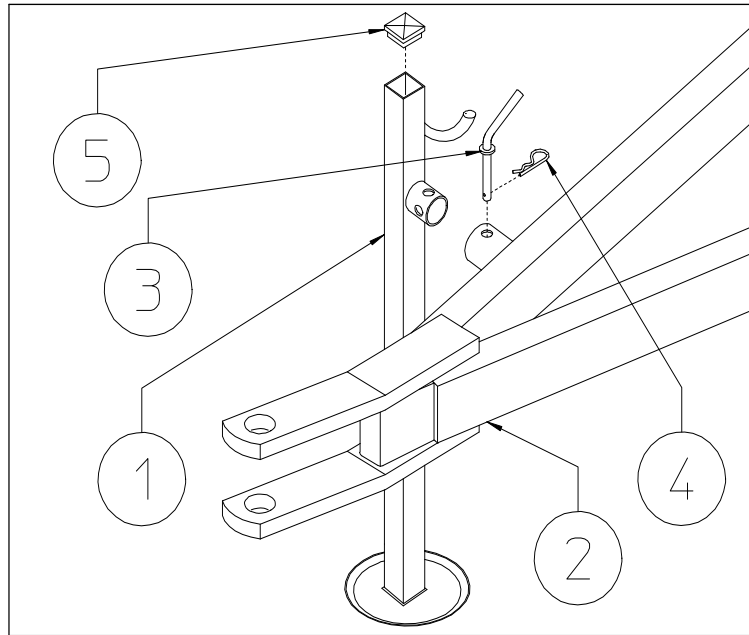

STEP “D”

Attach the parking stand 1 to drawbar 2 fastening it with pin 3 and clip 4. Place cap 5 on parking stand 1.

In this step, you will use:

Item 3 : 1 pin $\varnothing 15$ ($\varnothing 0.59''$)

Item 4 : 1 clip $\varnothing 3$ ($\varnothing 0.12''$)

Item 5 : 1 cap 40x40 (1.57'' x 1.57'')

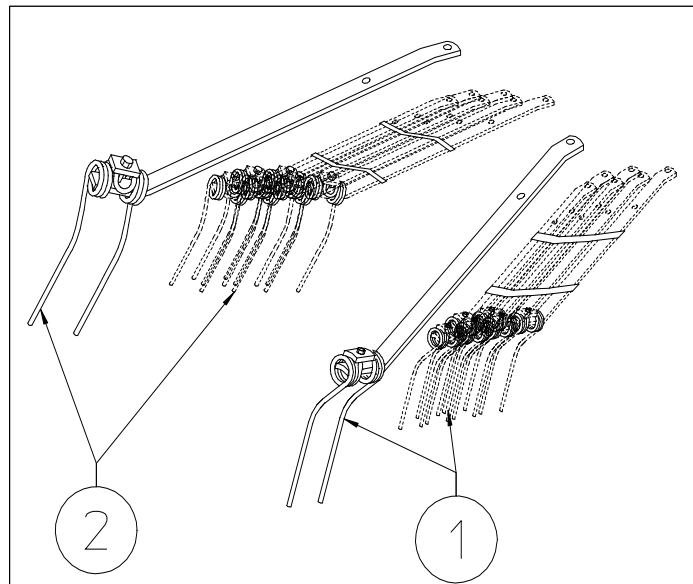

STEP “E”

You will find tine bars 1 (RH) and 2 (LH) in four bundles (two RH and two LH) of six pieces each. See pg.16.

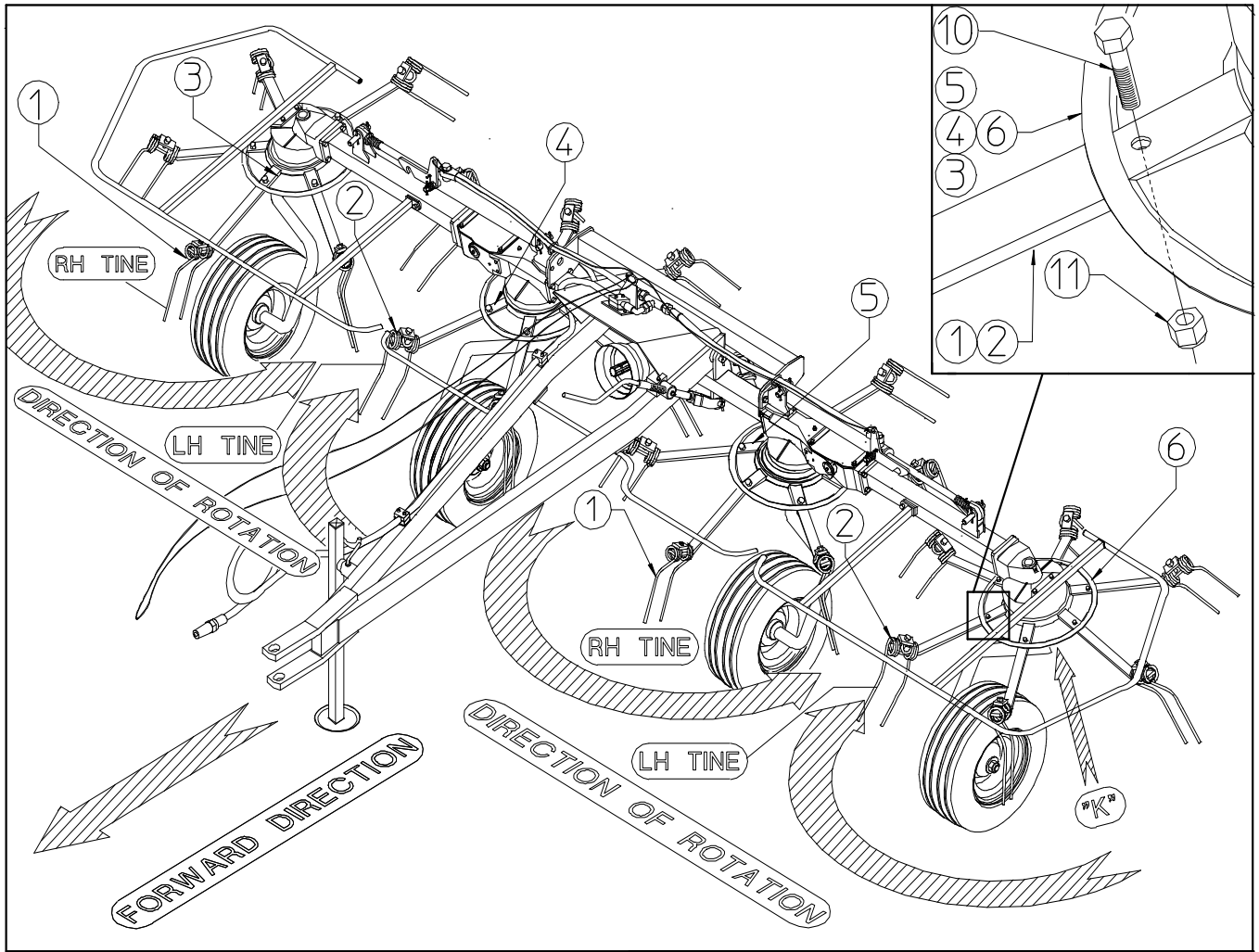

STEP "E"

Tine bars 1 (RH) are attached to rotors 3-5. Tine bars 2 (LH) are attached to rotors 4-6.

Attach tine bars 1 (RH) and 2 (LH) to respective rotors 3-5 (RH) and 4-6 (LH) with screws 7, spring washers 8, washers 8, screws 10 and nuts 11.

In this step, you will use:

- Item 7 : 24 screws M12x30 (0.47"x1.18")
- Item 8 : 24 spring washers $\varnothing 13$ ($\varnothing 0.51$ ")
- Item 9 : 24 washers $\varnothing 13$ ($\varnothing 0.51$ ")
- Item 10 : 24 screws M12x35 (0.47"x1.38")
- Item 11 : 24 nuts M12

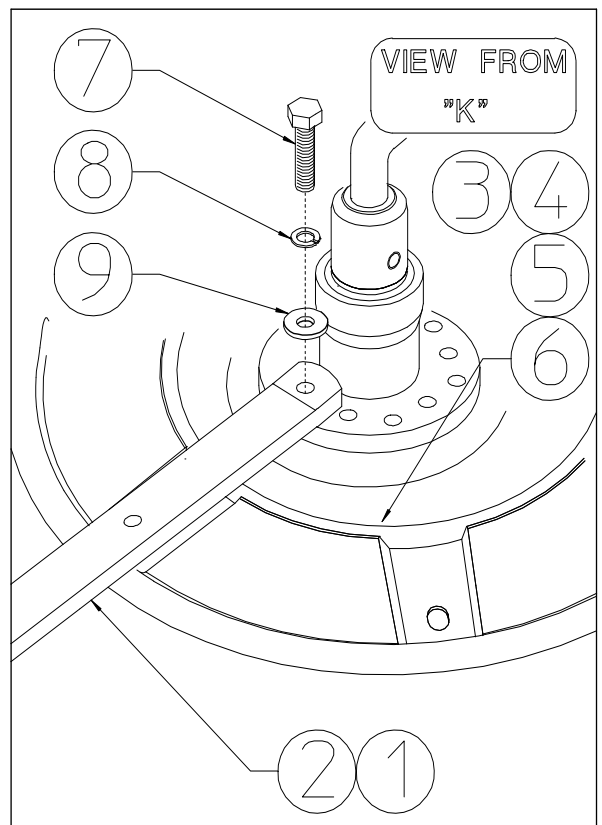

STEP “F”

Attach the central guard 1 to drawbar 2 using washers 3 and screws 4.

In this step, you will use:

Item 3 : 2 washers $\varnothing 13$ ($\varnothing 0.51$ "")

Item 4 : 2 screws M12x20 (0.47"x0.79"")

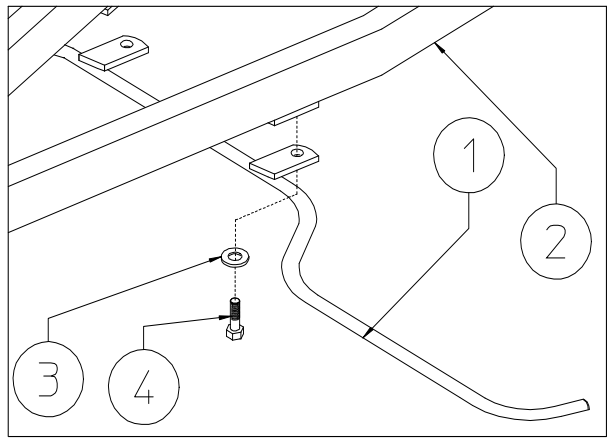

STEP “G”

Attach the lateral guard 1 (RH) and 2 (LH) to machine body using screws 3-4 and washers 5. Attach grease nipples 6 in the proper holes.

In this step, you will use:

Item 3 : 4 screws M12x25 (0.47"x1"")

Item 4 : 2 screws M12x20 (0.47"x0.79"")

Item 5 : 8 washers $\varnothing 13$ ($\varnothing 0.51$ "")

Item 6 : 2 grease nipples M10

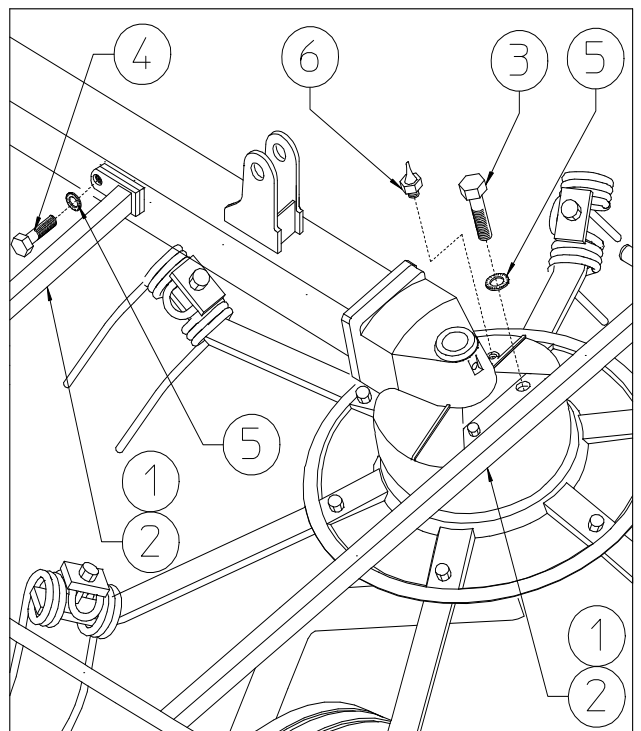

STEP “H”

Apply caps 4 to lateral guard 1-2 (RH-LH) and to center guard 3.

In this step, you will use:

Item 4 : 6 caps $\varnothing 27$ ($\varnothing 1.06$ "")

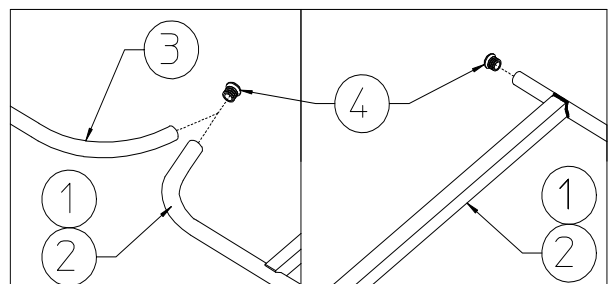

STEP "I"

Attach the guards 3 (RH and LH side) and plates 4-5 using washers 6 and screws 7. Attach grease nipples 1-2 in the proper holes (RH and LH side).

In this step, you will use:

Item 1 : 2 grease nipples M10

Item 2 : 4 grease nipples M6

Item 6 : 8 flat washers $\varnothing 8.5$ ($\varnothing 0.33''$)

Item 7 : 8 screws M8x16 ($0.31'' \times 0.63''$)

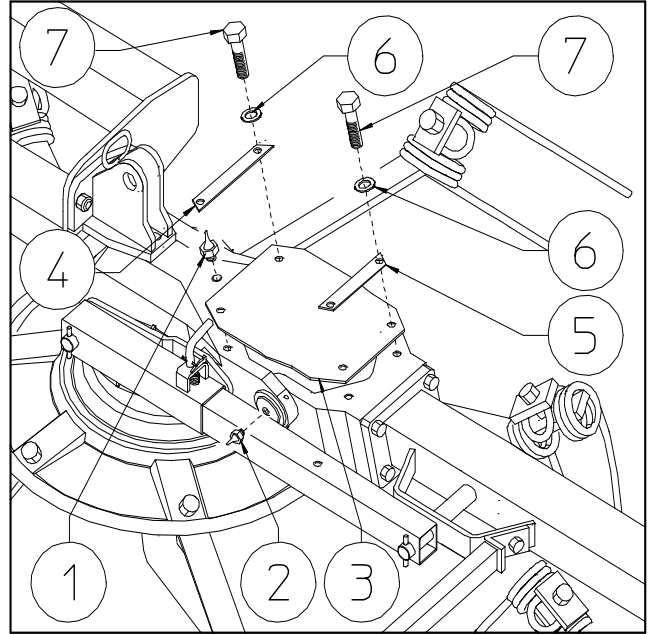

ASSEMBLING STEPS FOR HYDRAULIC KIT

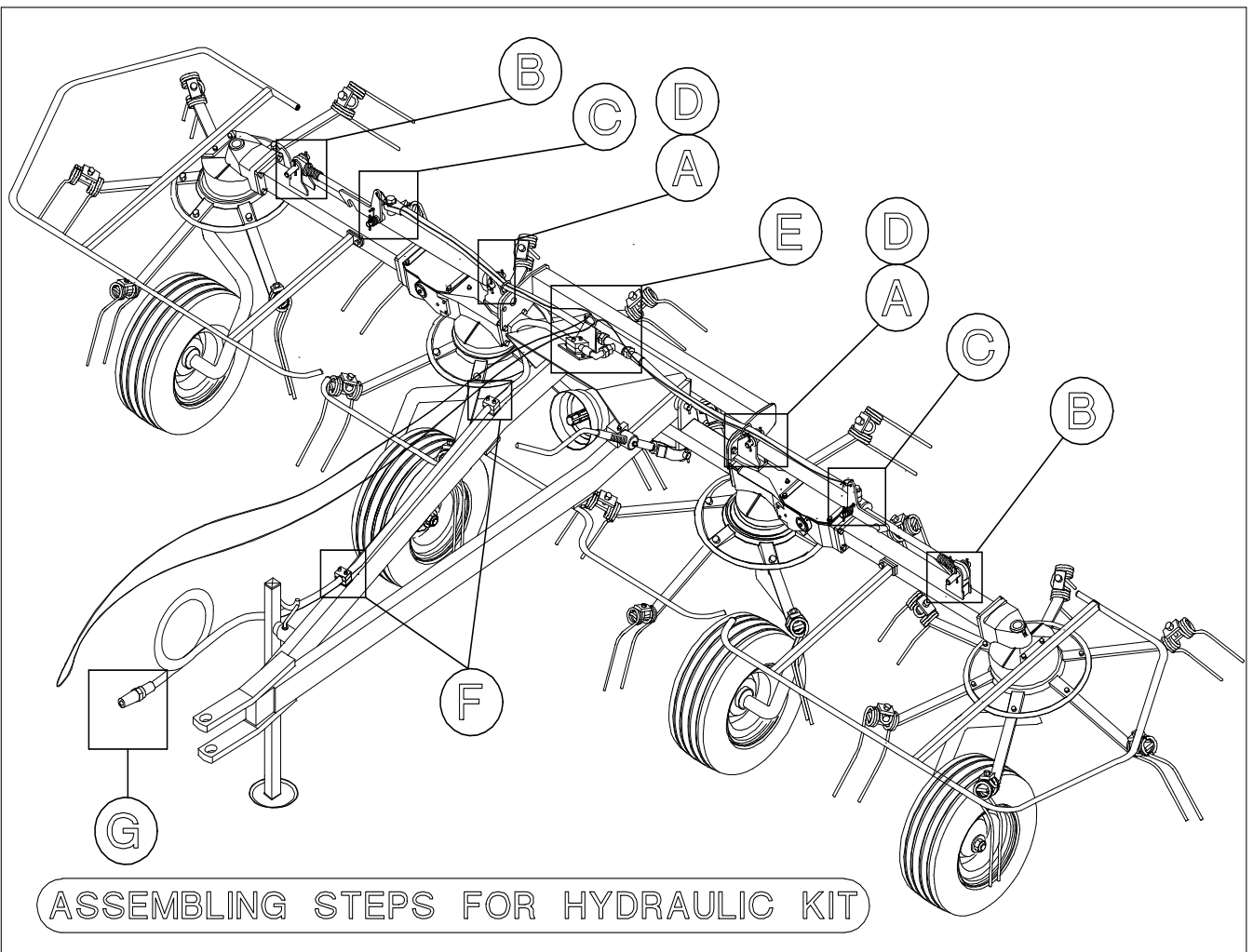

ASSEMBLING STEPS FOR HYDRAULIC KIT

STEP “A”

Attach the supports 1* (RH and LH side) using washers 3*-6*, screws 2*-5* and nuts 4*.
Attach the cylinders 7-8 (RH-LH) using pins 9 and spring pins 10.

In this step, you will use:

- Item 2*: 4 screws M12x35 (0.47”x1.38”)
- Item 3*: 6 flat washers \varnothing 13 (0.51”)
- Item 4*: 4 nut M12 (0.51”)
- Item 5*: 2 screws M12x25 (0.47”x1”)
- Item 6*: 2 spring washers \varnothing 13 (0.51”)
- Item 9 : 2 pins \varnothing 20x70 (0.79”x2.76”)
- Item 10 : 4 spring pins \varnothing 6x35 (0.24”x1.38”)

*They are valid if we convert a machine with manual fold into one with hydraulic fold.

These particulars are included on those machines already planned with hydraulic fold.

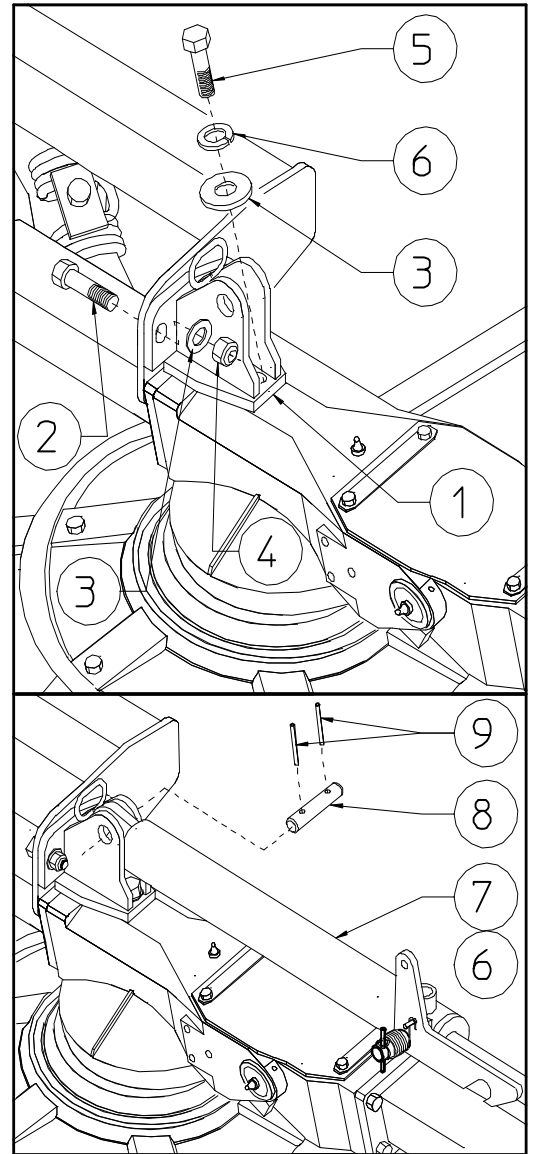

STEP “B”

Continue to secure cylinders 7-8 (RH-LH) using pins 1 and spring pins 2.

In this step, you will use:

- Item 1 : 2 pins \varnothing 20x95 (0.79”x3.74”)
- Item 2 : 4 spring pins \varnothing 6x35 (0.24”x1.38”)

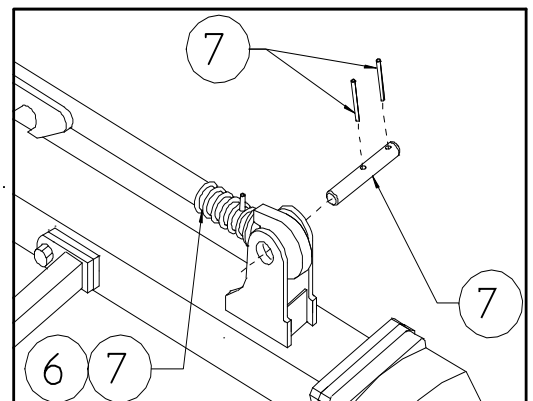

STEP “C-D”

Pass hoses 2 and rope 6 trough loops 7 on cylinder supports (RH and LH side).

Attach the eye hose 2 to hole 1 (RH and LH side) using washers 3 and fitting 4.

Fasten rope 6 to lever 5. (RH and LH side)

In this step, you will use:

Item 2 : 2 hoses 1/4”x1020 (1/4”x40”)

Item 3 : 4 copper washers 3/8”

Item 4 : 2 fittings 3/8”

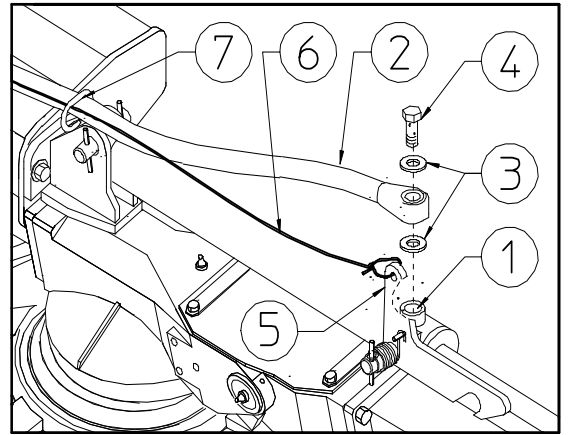

STEP “E”

Attach the support 1 to drawbar 3 using screws 4 and nuts 5. Join hoses 2 to connector 6. Attach nipple 7 to connector 6. Attach hose 8 to nipple 7. Secure hose 8 with collars 9 and screws 10. Pass rope 11 trough loop 12 on support 1.

In this step, you will use:

Item 2 : 2 hoses (step C-D)

Item 4 : 2 screws M6x16 (0.24”x0.63”)

Item 5 : 2 nut M6 (0.24”)

Item 6 : 1 “T” connector 1/4”

Item 7 : 1 nipple 1/4” - 3/8”

Item 8 : 1 hose 3/8”x2900 (3/8”x114”)

Item 9 : 2 hose collars ø18 (ø45/64”)

Item 10: 2 screws M6x25 (0.24”x1”)

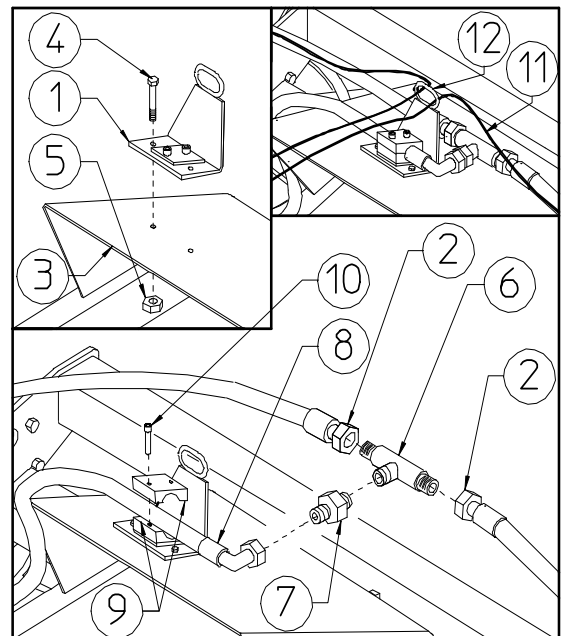

STEP “F-G”

Continue to secure hose 8 using collars 1 and screws 2. Attach the rapid coupling 4 and washer 3 to hose 8.

In this step, you will use:

Item 1 : 4 hose collars $\varnothing 18$ ($\varnothing 45/64$ ")

Item 2 : 4 screws M6x25 (0.24"x1")

Item 3 : 1 copper washer 1/2"

Item 4 : 1 rapid coupling 1/2"

Item 8 : hose (step E)

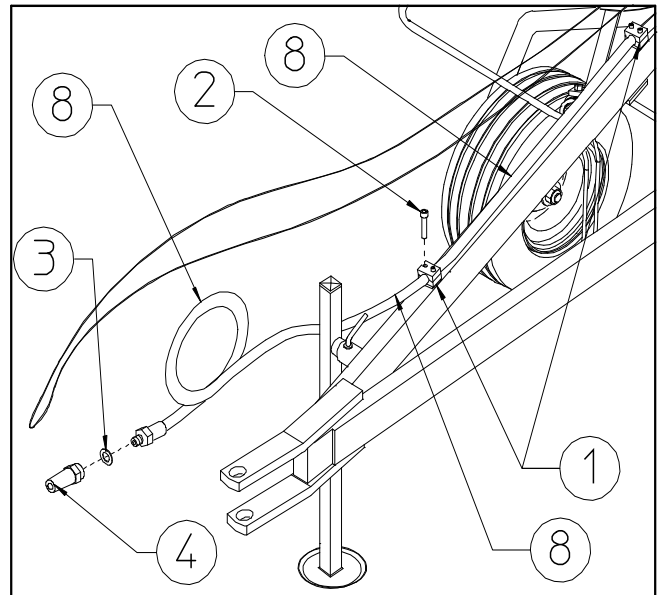

Assembly is now completed, and the machine should appear as shown in the illustration.

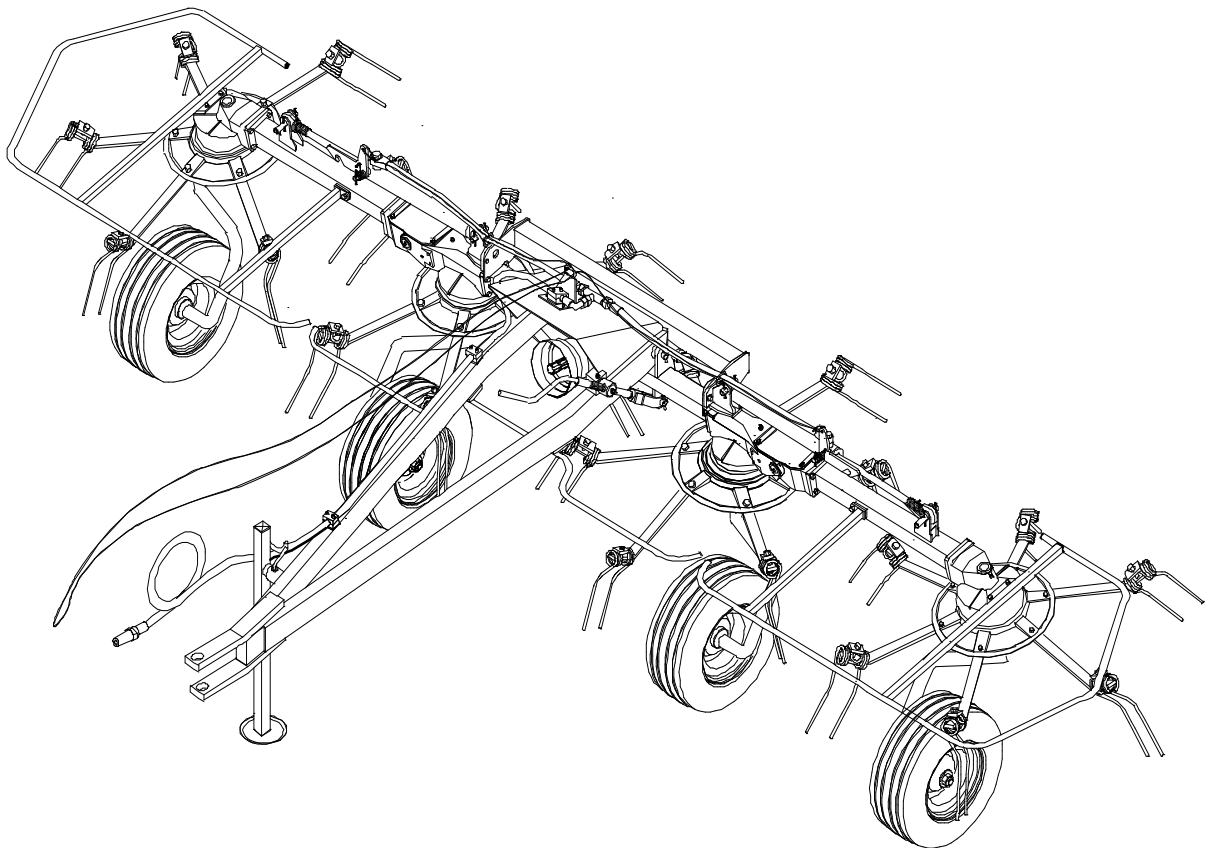

5) ADJUSTMENT, PREPARATION AND USE

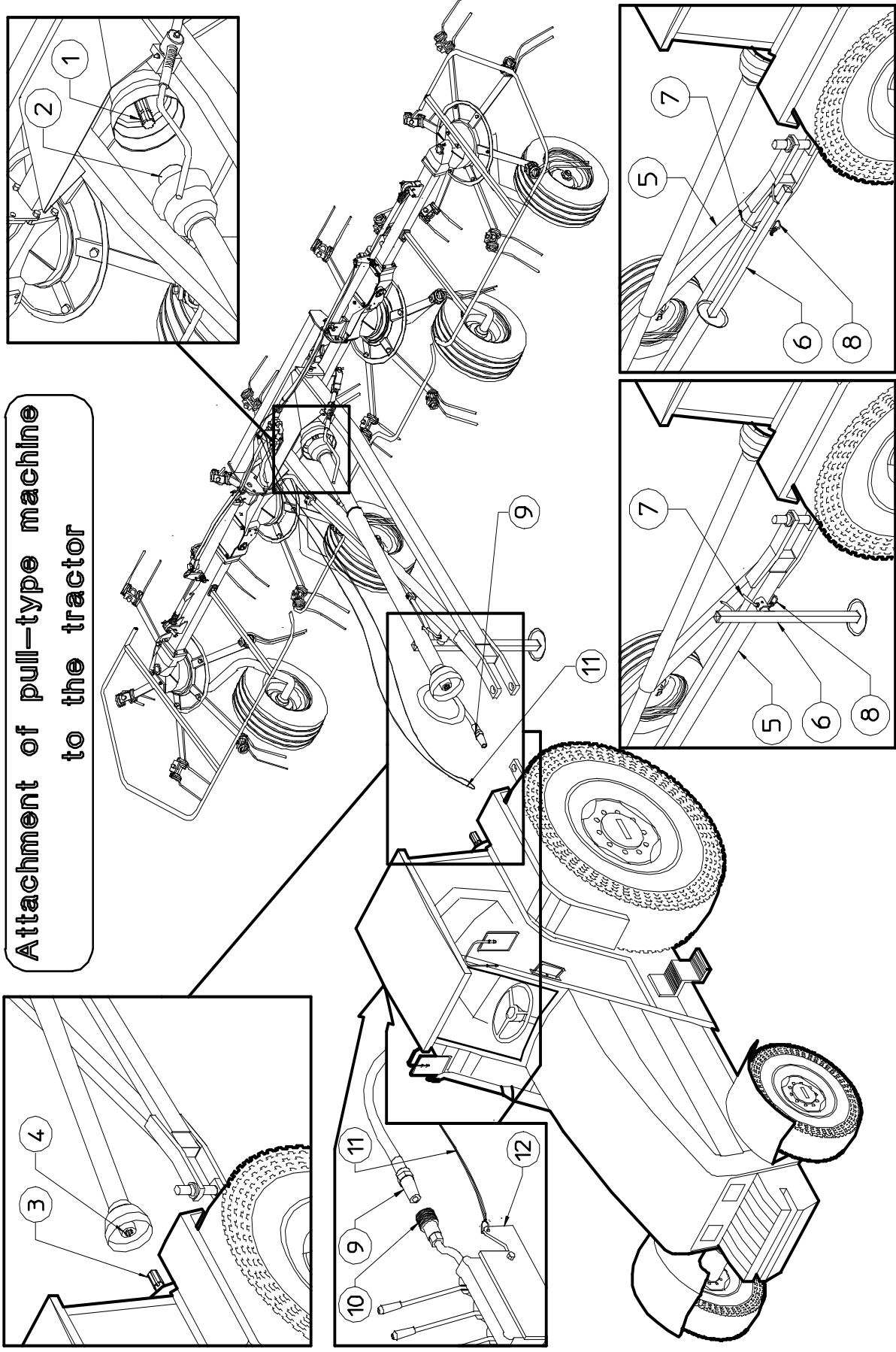

Attachment of pull-type machine to the tractor

5) ADJUSTMENT, PREPARATION AND USE

INTRODUCTION

Connection to the tractor is highly dangerous. Take great care and carry out the entire operation in strict compliance with the following instructions. Nobody should go near the area between the tractor and the machine. Check that all warning and danger signs are in place and legible. Check that the tractor is in good running order. Refer to the tractor operator's manual.

ATTACHMENT OF PULL-TYPE MACHINE TO THE TRACTOR

The attachment of pull-type machine to the tractor is very simple, as it is only necessary to couple the drawbar 5 to the tractor hitch using a pin of appropriate size, strength and shape. Always use extreme care when reversing the tractor towards the machine. Once the machine is hitched to the tractor, the parking stand 6 must be raised from the parking position. To do this, remove clip 8 and pin 7, and rotate the parking stand so that it is parallel with the drawbar 5. Fasten into the new position using pin 7 and clip 8. At this point quick-release coupling 9 should be attached to the tractor coupling 10. Fasten rope 11 to lever 12.

CONNECTING CARDAN SHAFT INFORMATION

More detailed information may be found in the cardan shaft manual which, together with this manual, is an essential part of the accident-prevention documentation. It is your responsibility to read and comply with this documentation. If information given in this manual should conflict with that given in the cardan shaft manual, you should follow the instructions given by the cardan shaft manufacturer.

CONNECTING THE CARDAN SHAFT

Fit the inner cardan shaft 2 at the machine shaft 1. Fit the outer cardan shaft 4 at the tractor shaft 3. Note: If a safety system is provided, this should be fitted to the machine shaft, not to tractor shaft.

NOTE: During both transport and use, avoid conditions where the cardan shaft is extended to the maximum. In all working conditions, the telescopic tube must overlap by at least 1/3 of their length (fig.1). Conversely, when the cardan shaft is contracted to the maximum, there should still be a gap of approximately 50mm-2" (fig.2).

Take particular care when connecting the two cardan shaft end forks and make sure that they are fully secured. This is achieved by inserting the safety pins and bolts 1 in the special slots 2 (fig.3) on the power takeoff shafts on both the tractor and machine ends. A loose shaft could come apart and cause considerable mechanical damage and serious injury to person.

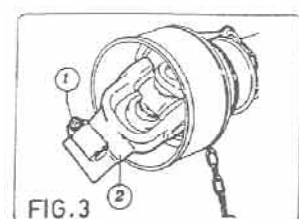
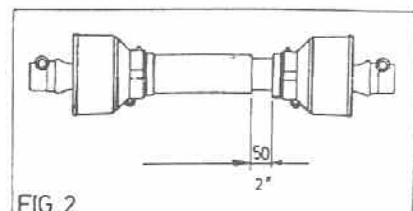
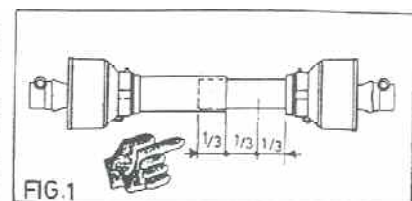

TRANSPORT INTRUCTIONS FOR
RT/5800 HYDRAULIC FOLD

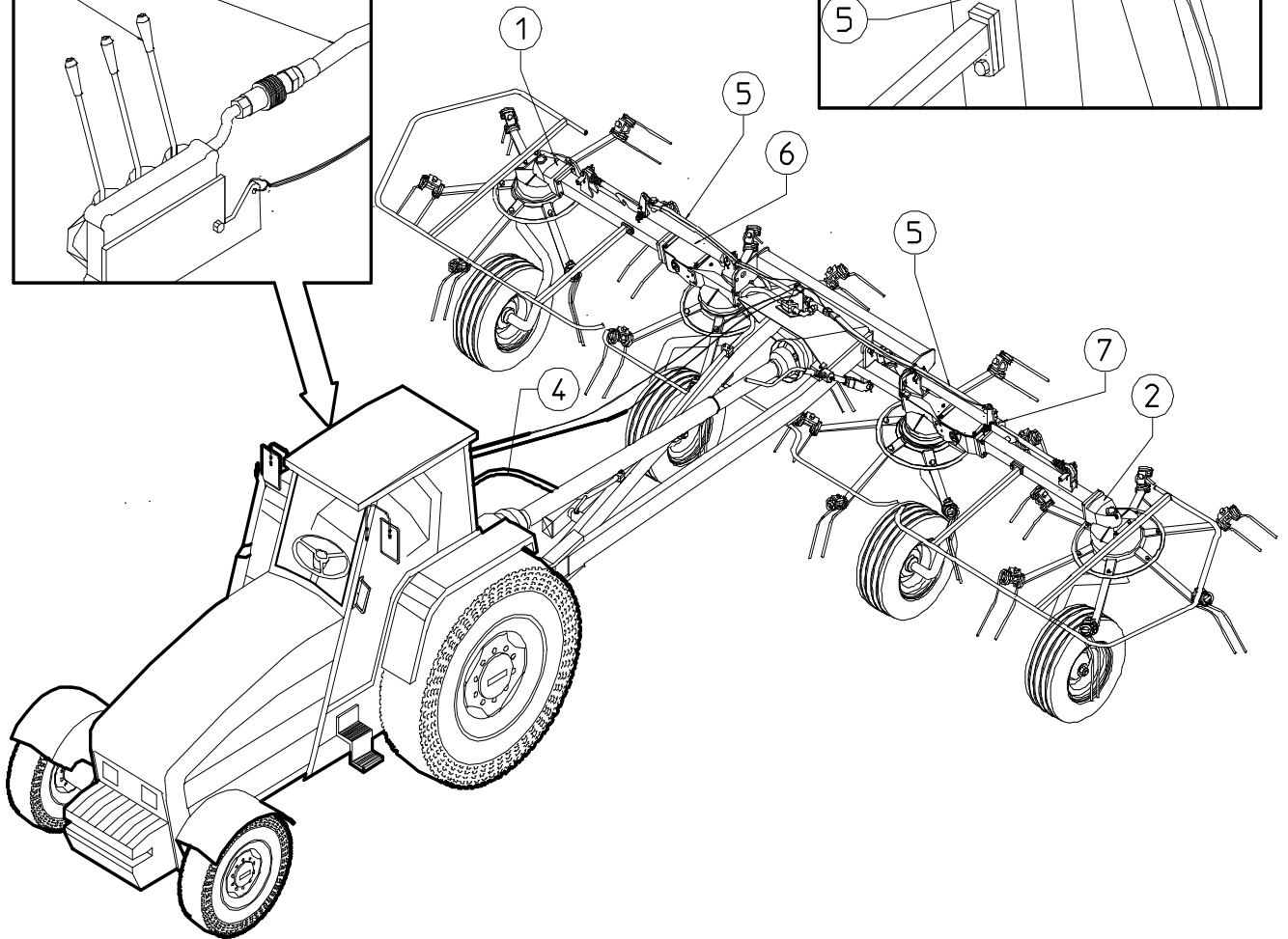
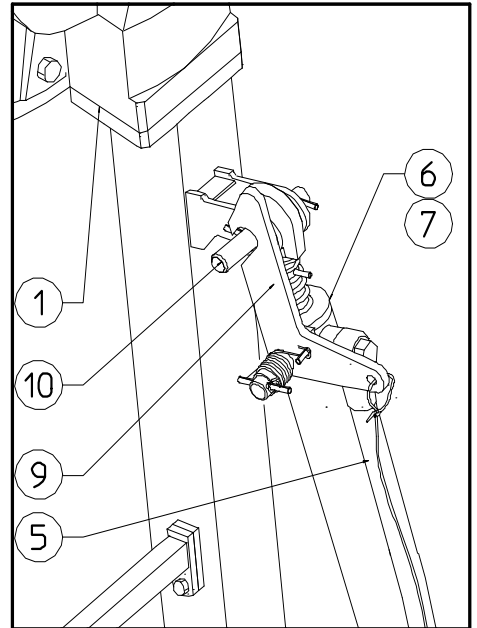
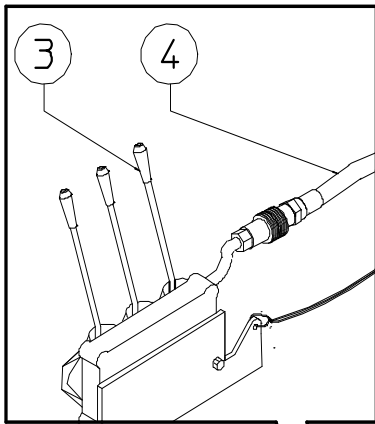

TRANSPORT INSTRUCTIONS FOR RT HYDRAULIC FOLD

Before transporting, the side arms 1-2 must be raised. To do this move the distributor lever 3, sending fluid through hoses 4-5 to cylinders 6-7, which will close, lifting the side arms 1-2. Before proceeding with transport, make sure that catch 9 is firmly hooked on pin 10 (RH and LH side) in order to guarantee safety while the machine is being transported.

NOTE: The machine ready for transport should appear as shown in the illustration.

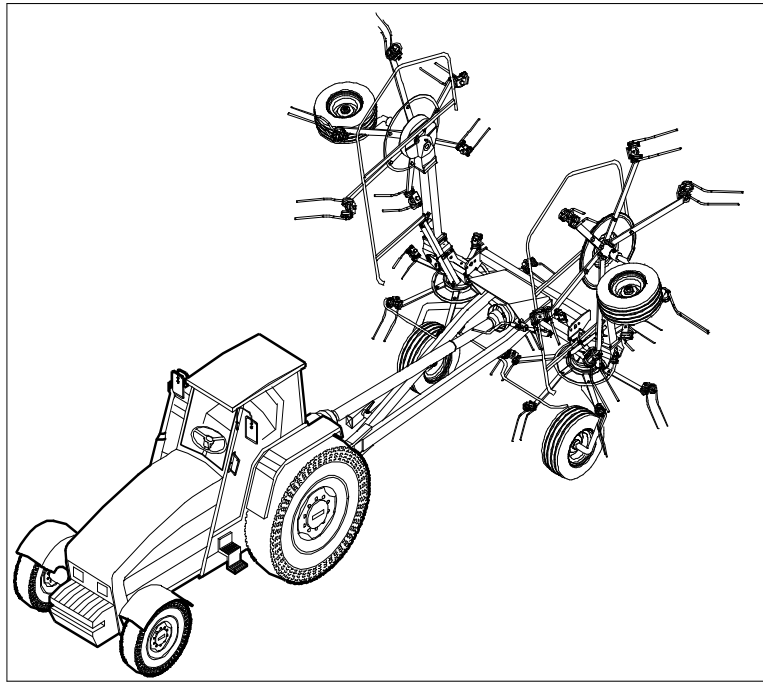

TRANSPORT BY ROAD

After the machine has been attached to the tractor as previously described and before transporting it to or from fields or any other workplace, the following instructions should be heeded:

Before setting off with the machine attached to the tractor, check the local road transport regulations. During transport keep the machine fully raised with the power takeoff disengaged and the lifting unit immobilised. Check that all guards, safety protection and locking split pins are in place, functioning and correctly fitted. Ensure that nobody leans against, or climbs on to, the machine during transport. The RT is an agricultural machine NOT designed for persons or goods. Consult the tractor maintenance and use manual where necessary. Maintain constant control over the vehicle and ensure that you know how to stop the tractor quickly and switch off the engine. When on a public road, observe all highway code regulations. Drive near the edge of the road and try not to obstruct traffic. Do not park the tractor and/or the machine where it might obstruct, or be a danger to, any public right of way. Avoid going onto a public road if the tractor or machine is very dirty you could leave a trail of soil, grass and other matter which could dirty the road and obstruct normal traffic.

USE IN THE FIELD

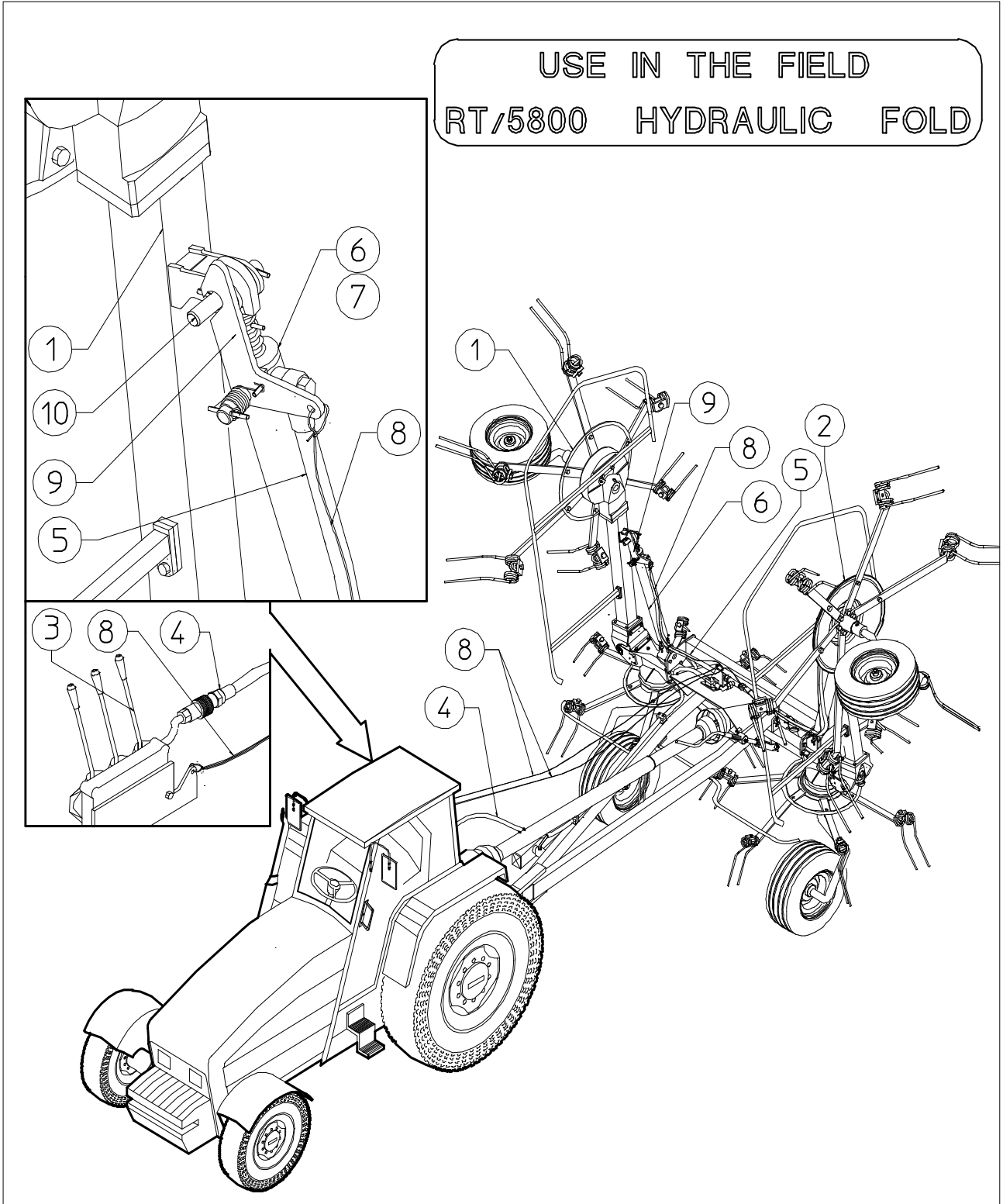

USE IN THE FIELD

To lower the side arms 1-2 of the RT/5800 hydraulic fold, move the distributor lever 3 so as to send fluid through hoses 4-5 to cylinders 6-7, which will close completely, pulling rope 8 at the same time as when moving distributor lever 3, thus making it possible to release catch 9 from pin 10 (RH and LH side), and then moving distributor lever 3 so as to lower side arms 1-2 down to the ground. (Cylinders 1-2 are single-acting, so the side arms 1-2 lower by their own weight, and therefore this operation must be carried out in a suitable area.)

ADJUSTMENT FOR CORRECT WORKING POSITION

These machines are very easily adjusted. For best operation, the tines 1 on the front side of the machine should brush the ground. To obtain this, turn the adjustment crank 2.

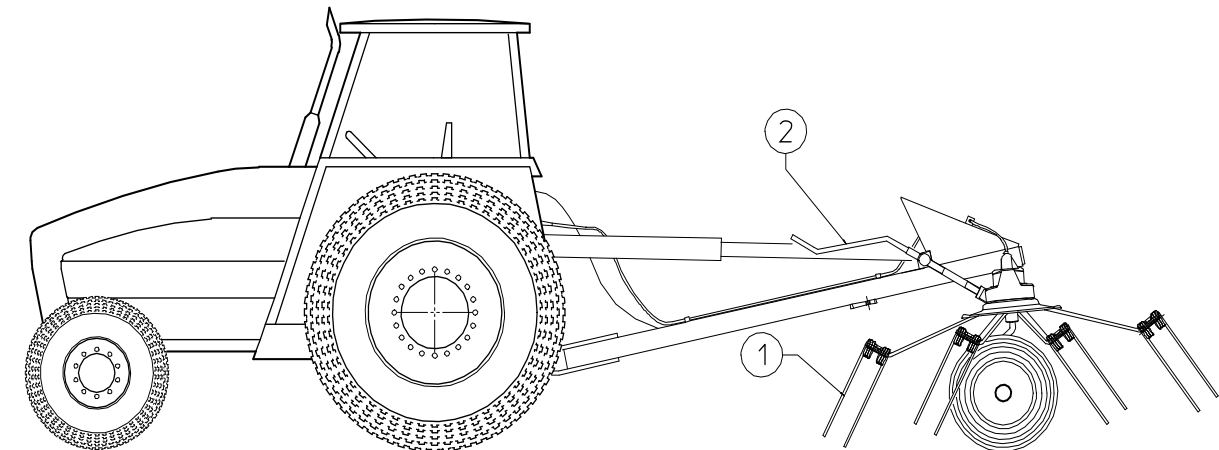

TEMPORARY PARKING

- 1) Choose a flat, hard open space away from frequented areas if possible.
- 2) Switch off the engine, leaving the tractor in gear.
- 3) Apply the parking brake and remove the ignition key.
- 4) Put the parking stand in the parking position.
- 5) Turn the angle adjustment crank so that the weight of the machine is on the parking stand, thus avoiding the risk of having the machine tip over backwards.
- 6) Disconnect the cardan shaft at the tractor end.
- 7) Unhitch the tractor drawbar coupling pin.

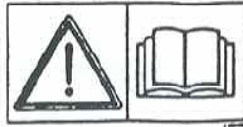

GENERAL INSTRUCTIONS FOR FIELD USE

Before starting work, familiarise yourself with the following general instructions:



Before using the machine ensure that all safety precautions are taken.

Check that all safety protection and guards are in place and working.

Inspect the work site in order to familiarise yourself with the terrain.

Do not start the tractor before being properly seated in the driving position.

Do not start the machine if it is damaged (or even if you only suspect it is damaged) and inform your nearest dealer of the problem and ask for assistance.

Do not allow yourself to become distracted when working - give your full attention to the job in hand.

Maintain constant control over the tractor and ensure that you know how to stop quickly and switch off the engine.

Caution when working on inclines. It is better to work from the bottom to the top of an incline (or from the top to the bottom), rather than across an incline where there is a risk of overturning. Check and heed the instructions supplied by the tractor manufacturer, especially those concerning the maximum incline on which it is possible to work.

It is advisable to reduce speed when working and manoeuvring on inclines and only to change speed and direction gradually.

Do not make sudden stops or starts.

Do not work on wet or slippery grass or terrain, or anywhere where grip is poor. If this is unavoidable, work at a slow speed so as to ensure operator safety.

Always switch off the tractor engine, apply the parking brake and remove the ignition key whenever you have to attend to the machine to make adjustments or to remove grass and other objects which might be entangled in the machine.

Before leaving the tractor, disengage the power takeoff, lower the machine until its wheels are on the ground and put the hydraulic directional control lever into the locked position.

Never go near the rotors until they have completely stopped moving.

Never attempt to make adjustments to the machine while it is running. Always stop the machine before carrying out any such work. Do not oil the machine when it is running or is connected to the power takeoff.

Do not use the control levers as handholds since they can move and do not give a secure grip. Furthermore, any involuntary movement of a control lever can cause unintentional movement of the tractor or machine.

6) MAINTENANCE DIRECTIONS

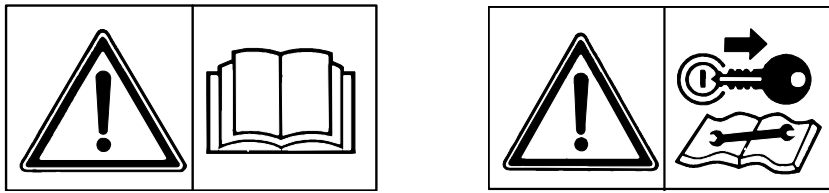

All cleaning, lubrication and maintenance operation must be carried out with the machine disconnected from the tractor.

In an emergency with the machine still connected to the tractor, switch off the engine, apply the parking brake, disengage the power takeoff and remove the ignition key from the instrument panel.

Regular, correct maintenance and proper operation are the basic prerequisites for the long-term efficiency and safe operation the machine.

Pay special attention to all instructions given on signs located on the machine.

All maintenance should be carried out in an area having the proper equipment readily available and in good condition.

This area must always be kept clean and dry and must have enough surrounding space to facilitate operations.

Any work must be carried out by trained personnel. Contact the dealer nearest to you. Respect the warnings and procedures for maintenance and technical assistance given in this manual.

Do not use petrol, solvents or other flammable liquids as detergents.

Use commercial non-flammable and non-toxic solvents, authorised by competent bodies.

Do not use compressed air or water at high pressure to clean the machine. If this is unavoidable, then wear goggles with side protection and limit the pressure as much as possible. When the work is finished, and with the machine disconnected from the tractor, inspect and check the machine completely.

6) MAINTENANCE POINTS

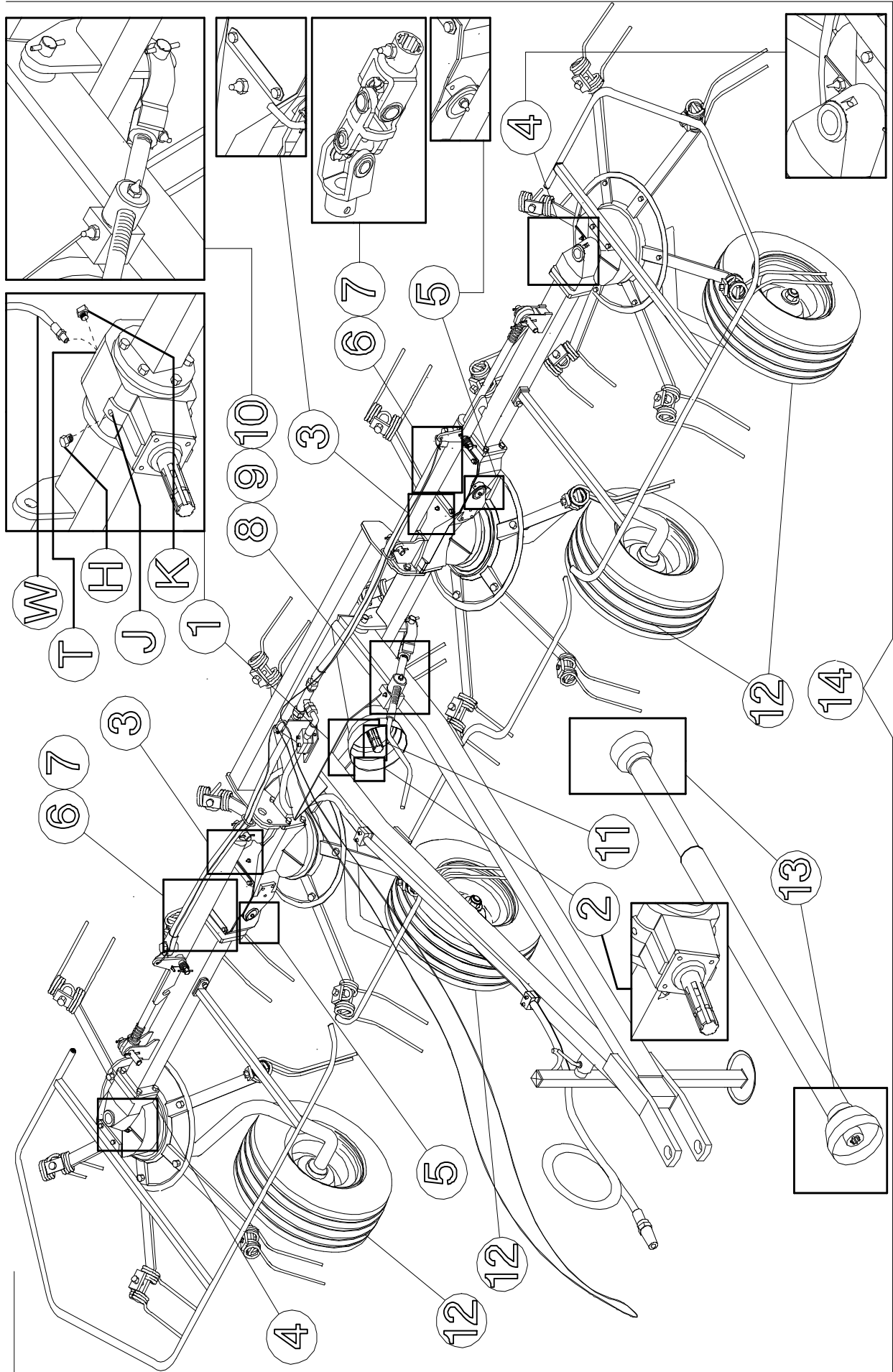

6) MAINTENANCE POINTS

ITEM	Q.ty	DESCRIPTION	OPERATION	EVERY HOURS	NOTES
1	1	GEARBOX	LUBRICATE	100	SEE NOTE A
2	1	BEARING OF THE GEARBOX	LUBRICATE	50	-
3	2	CENTRAL ROTORS	LUBRICATE	50	-
4	2	LATERAL ROTORS	LUBRICATE	50	-
5	4	SWIVEL HINGE PINS	LUBRICATE	50	-
6	4	UNIVERSAL JOINTS	LUBRICATE	8	-
7	2	KEYED COUPLING FORK	LUBRICATE	8	-
8	1	STRUT BUSHING	LUBRICATE	8	-
9	1	STRUT PIN	LUBRICATE	8	-
10	2	ADJUSTMENT FORK	LUBRICATE	8	-
11	1	PTO	CLEAN/ LUBRICATE	SEE NOTE B	WITH BRUSHES, etc
12	4	WHEELS	CHECK PRESSURE	SEE NOTE C	INFLATE TO 35 PSI
13	1	CARDAN SHAFT	SEE CARDAN SHAFT MAINTENANCE		
14	-	General checking of bolts, security pins and split pins to be carried out initially after the first 8 hours of use. Subsequently every 50 hours and whenever the machine is laid up for extended periods.			

NOTE A:

COMPLETE LUBRICATION OF THE CENTRAL GEARBOX 1:

The complete lubrication of gearbox 1 is done the first time at the manufacturer's plant, after which it must be topped up periodically, as according to the lubrication points table. A complete change or fill is necessary only for the replacement and /or repairing of the entire gearbox or internal parts. In this case, it is necessary to: remove caps H-K and inject the grease, using grease pump W, into hole T until the grease comes out of hole K. Then screw caps H-K back into place on central gearbox 1.

PERIODIC CHECKING AND TOPPING UP OF CENTRAL GEARBOX 1:

Every 100 hours of working time, check and top up central gearbox 1. It is a good practice, however, to check the condition and quantity of grease after all long periods of inactivity, especially when starting to work again after the winter break. To top up the grease in central gearbox 1 it is necessary to: remove caps H-K and inject the proper amount grease into hole J, using grease pump W. Then screw caps H back into place on housing 1.

B = Each time the Cardan shaft is disconnected and Whenever the machine is stopped, we recommended that you clean the power takeoff shaft and replace the protective cover (use additives of a type permitted by anti-pollution regulations).

C = Each time the machine is connected to the tractor.

CARDAN SHAFT MAINTENANCE



More detailed information may be found in the Cardan shaft manual which, together with this manual, forms an essential part of the accident-prevention documentation. It is your responsibility to read and comply with this documentation. If information given in this manual conflicts with that given in the Cardan shaft manual, you should follow the instructions given by the Cardan shaft manufacturer.

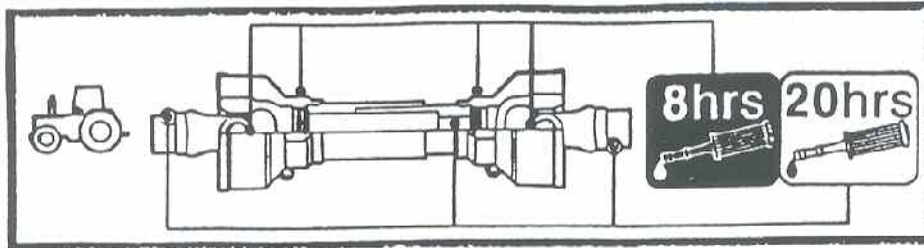

MAINTENANCE OF SLIDING PARTS

DISMANTLING

1) Turn the two eccentric pins on the ferrule until the protective cone comes free.

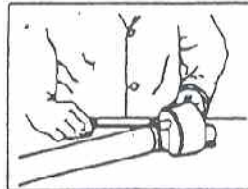

2) Withdraw the shaft protective guard.

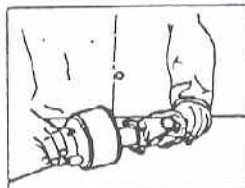

3) Check the condition of the ferrule and all protective parts.

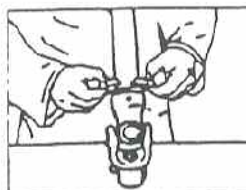

ASSEMBLY

4) Lubricate supporting ferrule seating.

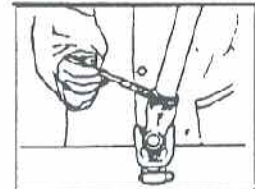

5) Refit the supporting ferrule.

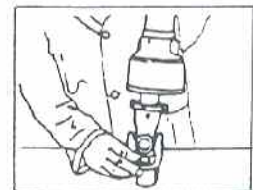

6) Reattach the protective guard to the cardan shaft by turning the eccentric pins on the supporting ferrule.

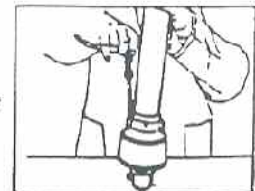

GENERAL INSTRUCTIONS FOR REPAIR WORK

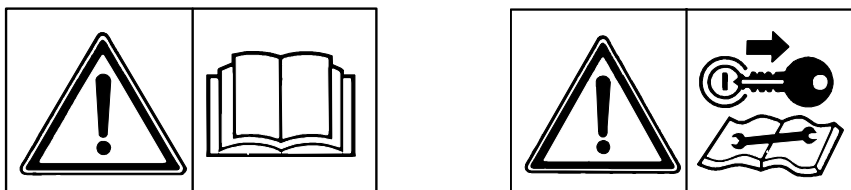

Any repair work must be carried out with the machine at rest and disconnected from the tractor.

Do not carry out welding without authorisation and instructions from the manufacturers.

Disconnect the machine from the tractor before any welding work in order not to damage the battery. Always use a protective mask, goggles and gloves when welding, sanding or grinding or when using a hammer or drill.

Always work on the machine out of doors. If you have to operate the machine when connected to the tractor in an enclosed area (for example when testing after repair and/or maintenance) ensure that there is sufficient ventilation so as to prevent noxious exhaust gases accumulating.

In order to acquire the necessary control and to operate in safety, practise various manoeuvres by simulating those required in the workplace with the help of an experienced person.

If you activate the machine while it is raised from the ground, make sure there is nobody standing nearby or in a dangerous position.

LAYNING UP FOR EXTENDED PERIODS

At the end of the season, or when an extended period of inactivity is envisaged, it is advisable to:

Clean the machine following instructions and allow it to dry.

Check it carefully and replace any damaged or worn parts.

Thoroughly tighten all screws and bolts.

Grease the machine thoroughly and then cover it completely and lay it up in a dry place.

It is to the user's advantage to carry out these operations carefully. In this way, he will have a machine in perfect condition when work is restarted.

On recommencing work, repeat all the proper checks so as to be certain of working in conditions of maximum safety.

NOISE AND VIBRATION

Noise affecting the tractor driver (from the machine only) is less than 80dB.

Vibration from the machine affecting the upper body and limbs of the driver is insignificant and is lower than the values given in Point 3.6.3 of Enclosure 1 of the Machine Directives (89/392/EEC, 91/386/EEC)

THE FOLLOWING SHOULD BE NOTED IF THE MACHINE IS SCRAPPED

The machine consists mainly of ferrous material, which must be disposed of according to the regulations in force in the country concerned.

There is also a small amount of plastic, which must be disposed of according to the regulations in force in the country concerned.

There is very small amount of residual grease, which must be disposed of according to the regulations in force in the country concerned.

SPARE PARTS LIST

FOR CORRECT SPARE PARTS ORDER IT IS NECESSARY TO SPECIFY:
TABLE NUMBER, ITEM, PART NO, DESCRIPTION AND QUANTITY OF
PARTS REQUIRED.

ITEMS DESCRIBED AS RH AND LH ARE MEANT FACING REAR OF
MACHINE.

**RT/5800-H
HYDRAULIC LIFT VERSION**

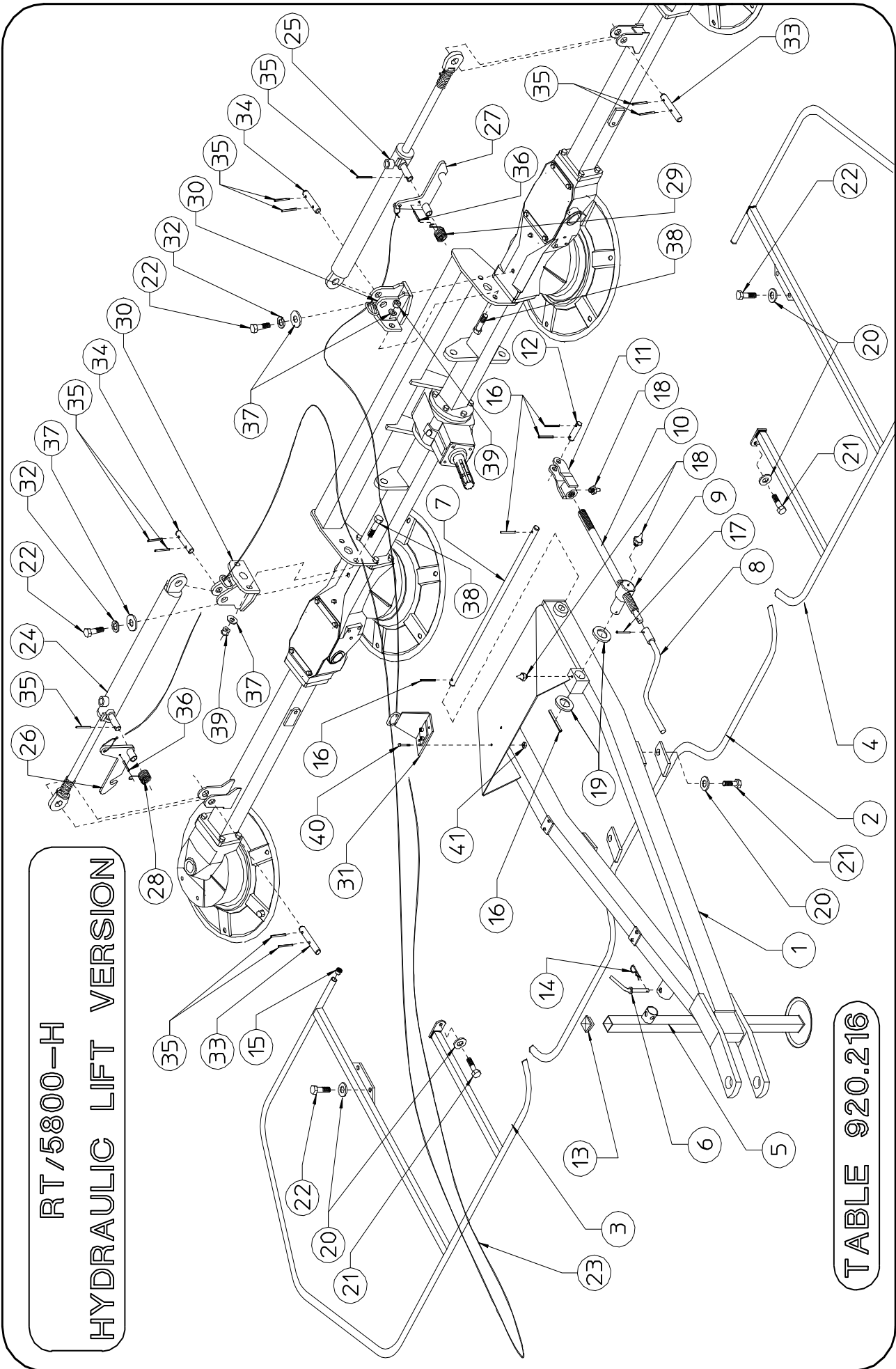
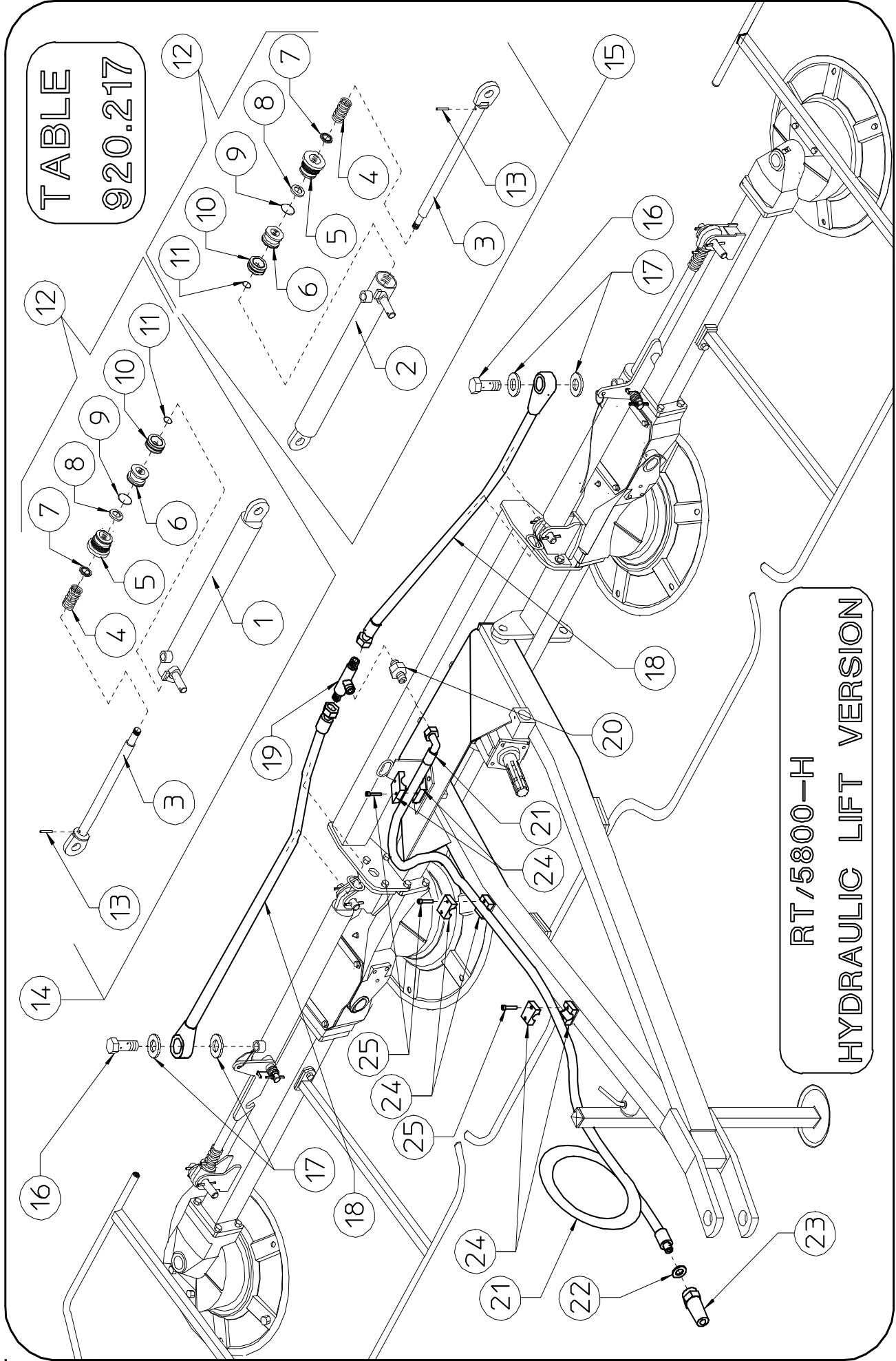

TABLE 920.216

RT/5800-H - TABLE PART NO 920.216

ITEM	Q.ty	PART NO	DESCRIPTION	NOTE
1	1	220.796	DRAWBAR	
2	1	220.837	CENTER GUARD	
3	1	220.838	RH LATERAL GUARD	
4	1	220.839	LH LATERAL GUARD	
5	1	200.946	STAND	
6	1	200.959	PIN	
7	1	220.790	PIN	
8	1	200.438	HANDLE	
9	1	220.807	PIN	
10	1	200.766	TIE ROD	
11	1	220.808	FORK	
12	1	220.809	PIN	
13	1	600.817	PLUG	
14	1	600.019	PIN	
15	6	600.854	PLUG	
16	5	600.673	SPRING PIN (ø5x40)	
17	1	600.580	SPRING PIN (ø6x26)	
18	3	600.124	GREASE NIPPLE (M6)	
19	2	200.273	SHIM (ø30,3/39,8x1)	
20	8	600.634	SPRING WASHER (ø13-ZN)	
21	4	600.770	SCREW (M12x20 5739-ZN)	
22	6	600.441	SCREW (M12x25 5739-ZN)	
23	1	210.009	ROPE	
24	1	220.822	RH CYLINDER	
25	1	220.823	LH CYLINDER	
26	1	210.098	RH COUPLER	
27	1	210.099	LH COUPLER	
28	1	210.093	RH SPRING	
29	1	210.094	LH SPRING	
30	2	220.825	HITCH	
31	1	220.826	SUPPORT	
32	2	600.018	SPRING WASHER (ø13-ZN)	
33	2	210.103	PIN	
34	2	220.828	PIN	
35	10	600.538	SPRING PIN (ø6x35)	
36	2	600.773	SPRING PIN (ø6x30)	
37	6	600.089	WASHER (ø13-ZN)	
38	4	600.616	SCREW (M12x35 5739-ZN)	
39	4	600.077	NUT (M12 DIN 980)	
40	2	620.278	SCREW (M6x16 5739-ZN)	
41	2	600.472	NUT (M6 DIN 980)	

**TABLE
920.217**



**RT/5800-H
HYDRAULIC LIFT VERSION**

RT/5800-H - TABLE PART NO 920.217				
ITEM	Q.ty	PART NO	DESCRIPTION	NOTE
1	1	220.829	CYLINDER BARREL, RH	
2	1	220.830	CYLINDER BARREL, LH	
3	2	220.831	ROD	
4	2	200.947	SPRING	
5	2	210.288	CYLINDER HEAD	
6	2	210.289	PISTON	
7	2	610.025	GASKET	
8	2	610.027	GASKET	
9	2	610.026	GASKET	
10	2	610.028	GASKET	
11	2	610.029	GASKET	
12	2	600.895	SET OF GASKET	
13	2	600.106	SPRING PIN (ø3,5x18)	
14	1	220.822	RH CYLINDER, COMPLETE	
15	1	220.823	LH CYLINDER, COMPLETE	
16	2	600.820	FITTING (3/8")	
17	4	600.819	COPPER WASHER (ø1/4")	
18	2	620.286	HOSE (1/4")	
19	1	600.880	"T" ADAPTOR (1/4")	
20	1	600.883	NIPPLE (1/4"-3/8")	
21	1	620.240	HOSE (3/8")	
22	1	600.269	COPPER WASHER (ø1/2")	
23	1	600.273	QUICK COUPLER (1/2")	
24	6	610.035	HALF HOSE COLLAR	
25	6	610.037	SCREW (M6x25 5931-ZN)	

RT/5800-H

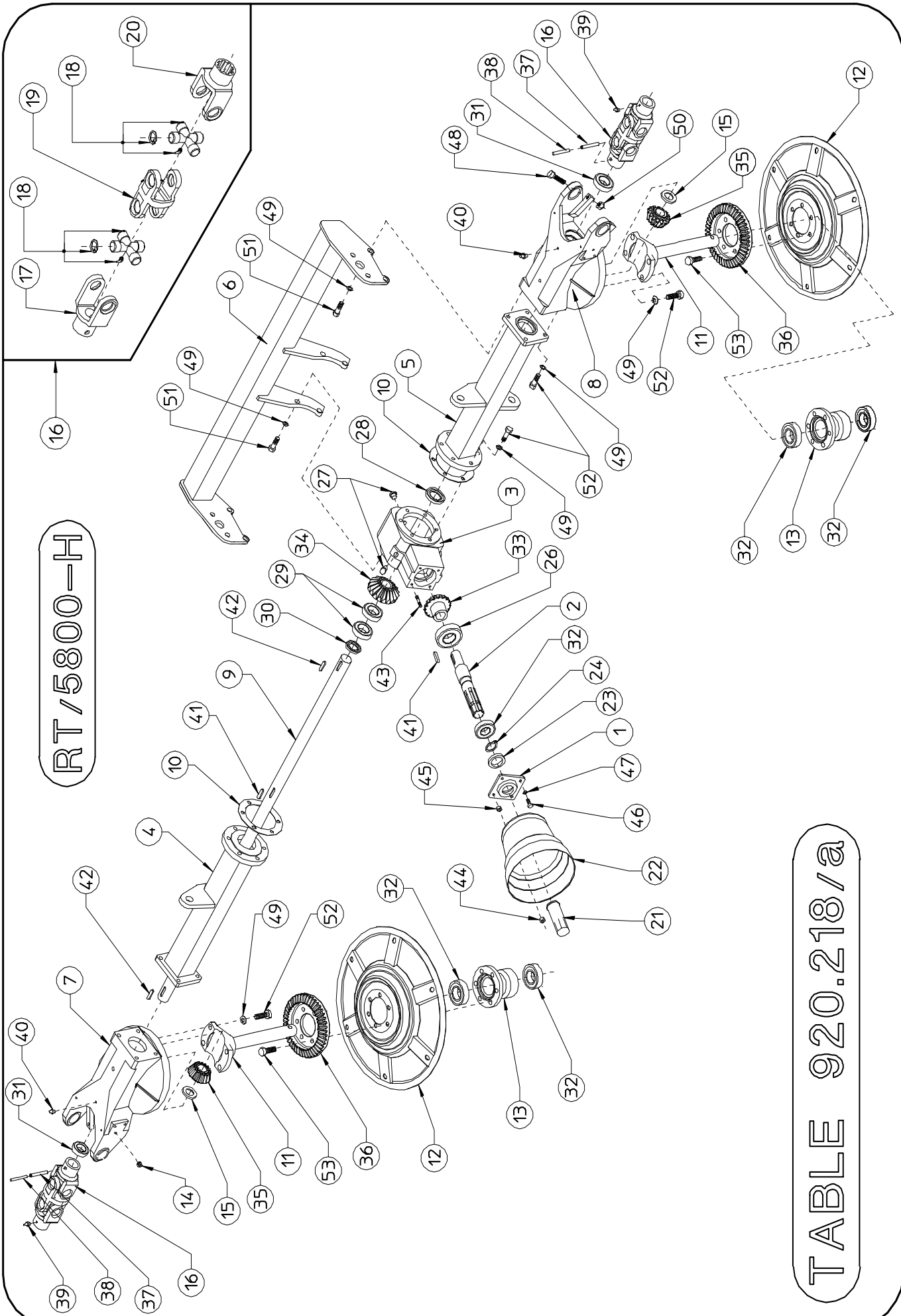

TABLE 920.218/a

RT/5800-H - TABLE PART NO 920.218/a

ITEM	Q.ty	PART NO	DESCRIPTION	NOTE
1	1	200.395	GEARBOX CAP	
2	1	220.396	SHAFT	
3	1	230.225	GEARBOX	
4	1	220.791	RH CENTER AXLE	
5	1	220.792	LH CENTER AXLE	
6	1	220.795	REINFORCEMENT	
7	1	220.652	RH FORK SUPPORT	
8	1	220.653	LH FORK SUPPORT	
9	1	220.788	DRIVE SHAFT	
10	2	200.405	GASKET	
11	2	200.471	PIN	
12	2	220.834	TINE DISC	
13	2	220.836	HUB	
14	6	600.896	PLUG	
15	2	200.851	SHIM	
16	2	200.857	JOINT, COMPLETE	
17	2	600.813	FORK	
18	4	600.814	CROSS, COMPLETE	
19	2	600.815	CENTER JOINT	
20	2	600.816	SPLINED FORK	
21	1	600.172	SHAFT GUARD	
22	1	600.681	HOOD	
23	1	600.555	OIL RETAINER (ø35/52x10)	
24	1	600.333	SNAP RING (E35-7435)	
26	1	600.827	BEARING (6209 2RS)	
27	2	600.560	PLUG (3/8")	
28	1	600.561	OIL RETAINER (ø30/62x10)	
29	2	600.579	BEARING (6206)	
30	1	600.582	OIL RETAINER (ø30/56x10)	
31	2	600.609	BEARING (6206 2RS)	
32	5	600.608	BEARING (6207 2RS)	
33	1	200.397	PINION	
34	1	200.400	CROWN	
35	2	200.420	PINION	
36	2	220.833	CROWN	
37	2	600.541	SPRING PIN (ø10x55-6873)	
38	2	600.562	SPRING PIN (ø6x55-6873)	
39	2	600.124	GREASE NIPPLE (M6)	
40	2	600.247	GREASE NIPPLE (M10)	
41	2	600.556	FLAT KEY (B8x7x40-6604)	
42	2	600.559	FLAT KEY (B8x7x30-6604)	
43	2	600.558	BOLT (M8x30-5911)	
44	2	600.037	NUT (M8-5588)	
45	2	600.552	NUT (M8-5587)	
46	2	600.222	SCREW (M8x20-5739)	
47	2	600.228	SPRING WASHER (ø8,4)	
48	4	600.153	SCREW (M12x45-5739)	
49	28	600.049	SPRING WASHER (ø13)	
50	4	600.077	NUT (M12 DIN 980)	
51	8	600.687	SCREW (M12x45-5737)	
52	20	600.615	SCREW (M12x35-5739)	
53	12	600.004	SCREW (M12x30-5739)	

RT/5800-H

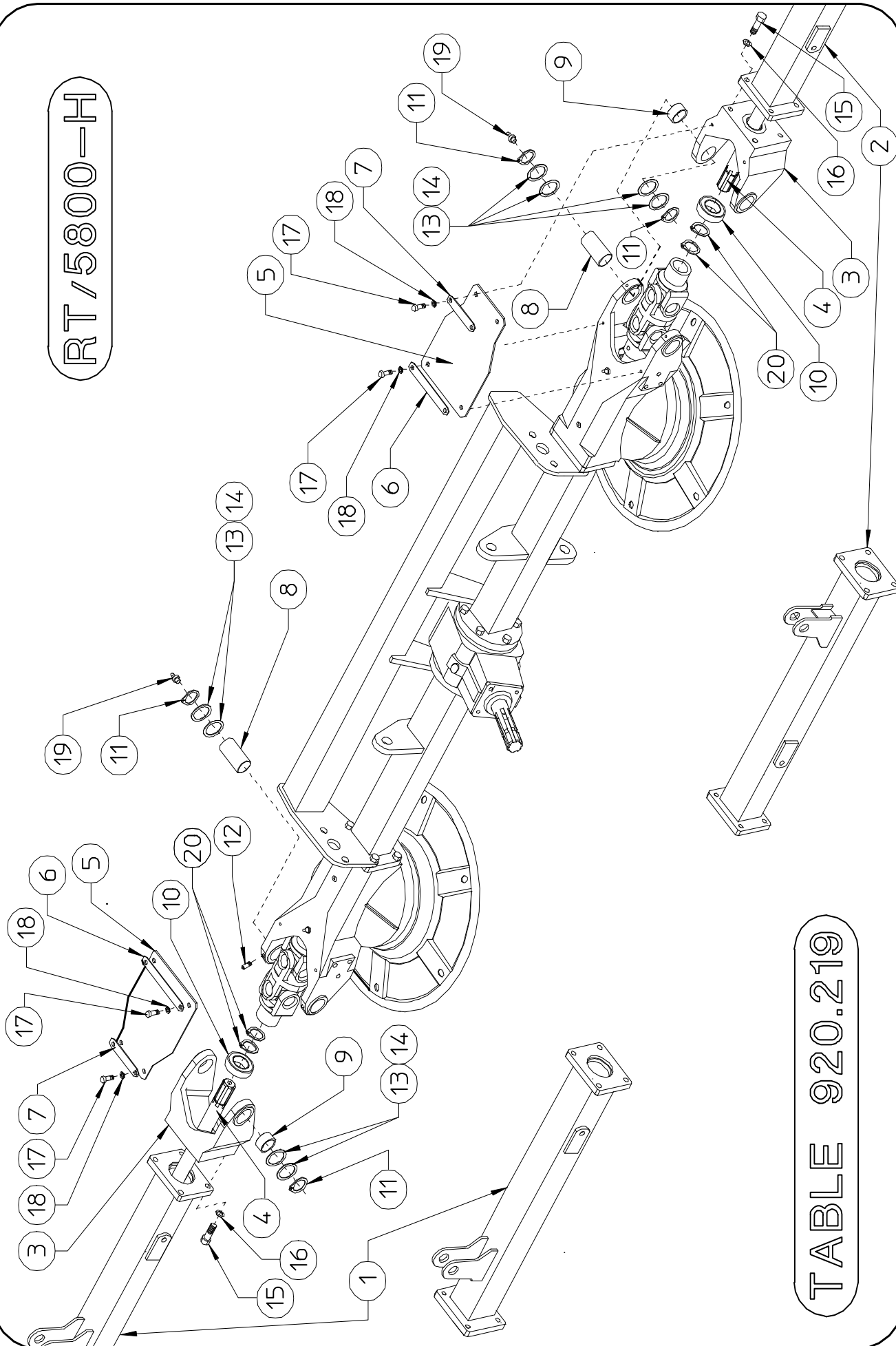
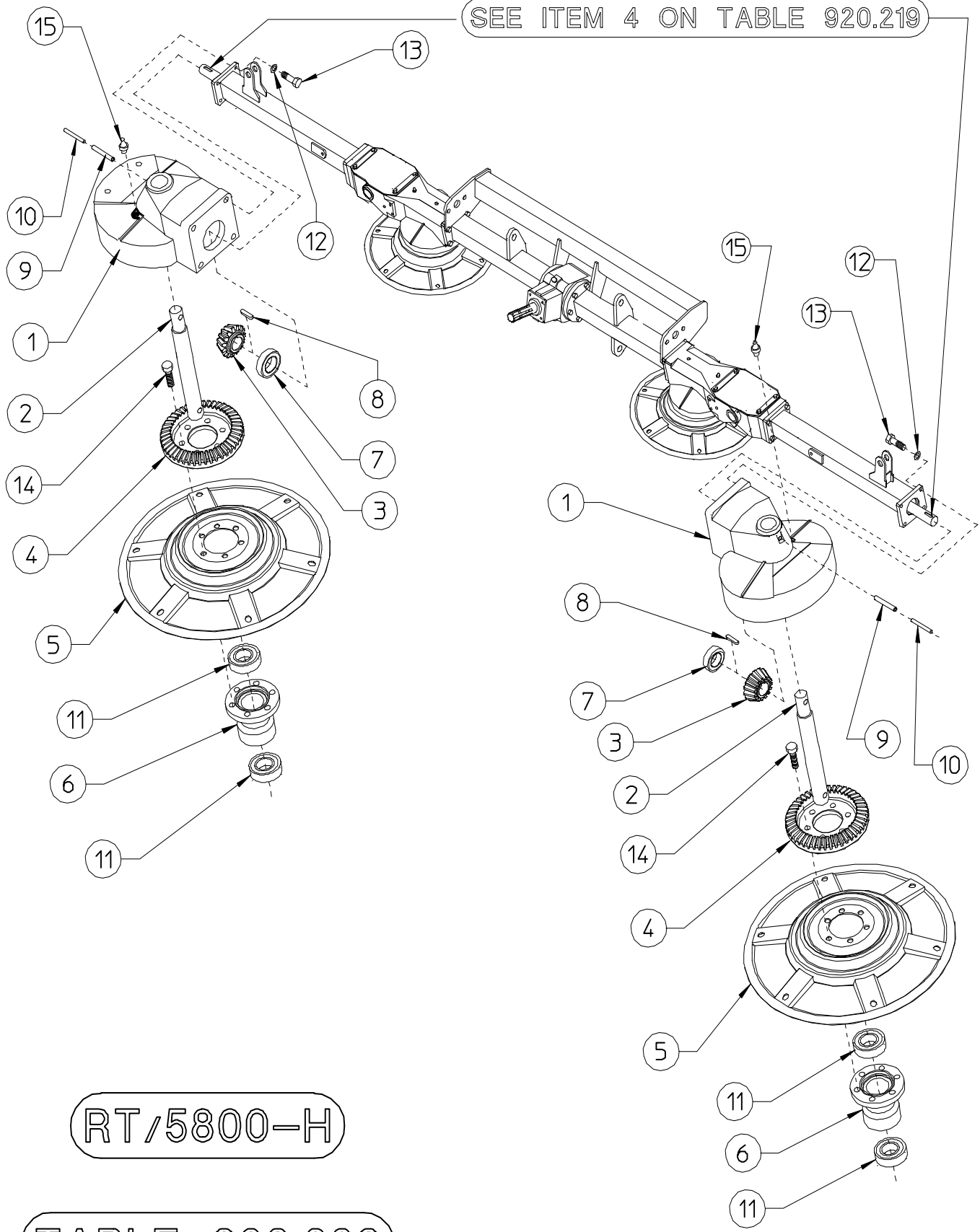

TABLE 920.219

RT/5800-H -TABLE PART NO 920.219				
ITEM	Q.ty	PART NO	DESCRIPTION	NOTE
1	1	220.793	RH LATERAL AXLE	
2	1	220.794	LH LATERAL AXLE	
3	2	220.651	FORK	
4	2	220.789	LATERAL SHAFT	
5	2	220.810	GUARD	
6	2	220.811	PLATE	
7	2	220.812	PLATE	
8	4	200.850	PIN	
9	4	600.808	BUSH (ø30/34x20)	
10	2	600.609	BEARING (6206 2RS)	
11	8	600.611	SNAP RING (E30-7435)	
12	4	600.809	BOLT (M8x12-5927)	
13	4	200.272	SHIM (ø30,3/39,8x0,5)	
14	4	200.273	SHIM (ø30,3/39,8x1)	
15	8	600.615	SCREW (M12x35-5739)	
16	8	600.049	SPRING WASHER (ø13)	
17	8	600.061	SCREW (M8x16-5739 ZN)	
18	8	600.115	WASHER (ø8,4 ZN)	
19	4	600.124	GREASE NIPPLE (M6)	
20	4	620.353	SNAP RING (E29-7435)	

SEE ITEM 4 ON TABLE 920.219



RT/5800-H

TABLE 920.220

RT/5800-H -TABLE PART NO 920.220				
ITEM	Q.ty	PART NO	DESCRIPTION	NOTE
1	2	220.637	GEAR BOX	
2	2	200.407	PIN	
3	2	200.420	PINION	
4	2	220.833	CROWN	
5	2	220.834	TINE DISC	
6	2	220.836	HUB	
7	2	600.609	BEARING (6206 2RS)	
8	2	600.559	FLAT KEY (B8x7x30-6604)	
9	2	600.541	SPRING PIN (ø10x55-6873)	
10	2	600.562	SPRING PIN (ø6x55-6873)	
11	4	600.608	BEARING (6207 2RS)	
12	8	600.049	SPRING WASHER (ø13)	
13	8	600.615	SCREW (M12x35-5739)	
14	12	600.004	SCREW (M12x30-5739)	
15	2	600.247	GREASE NIPPLES (M10)	

TABLE 920.221

RT/5800-H

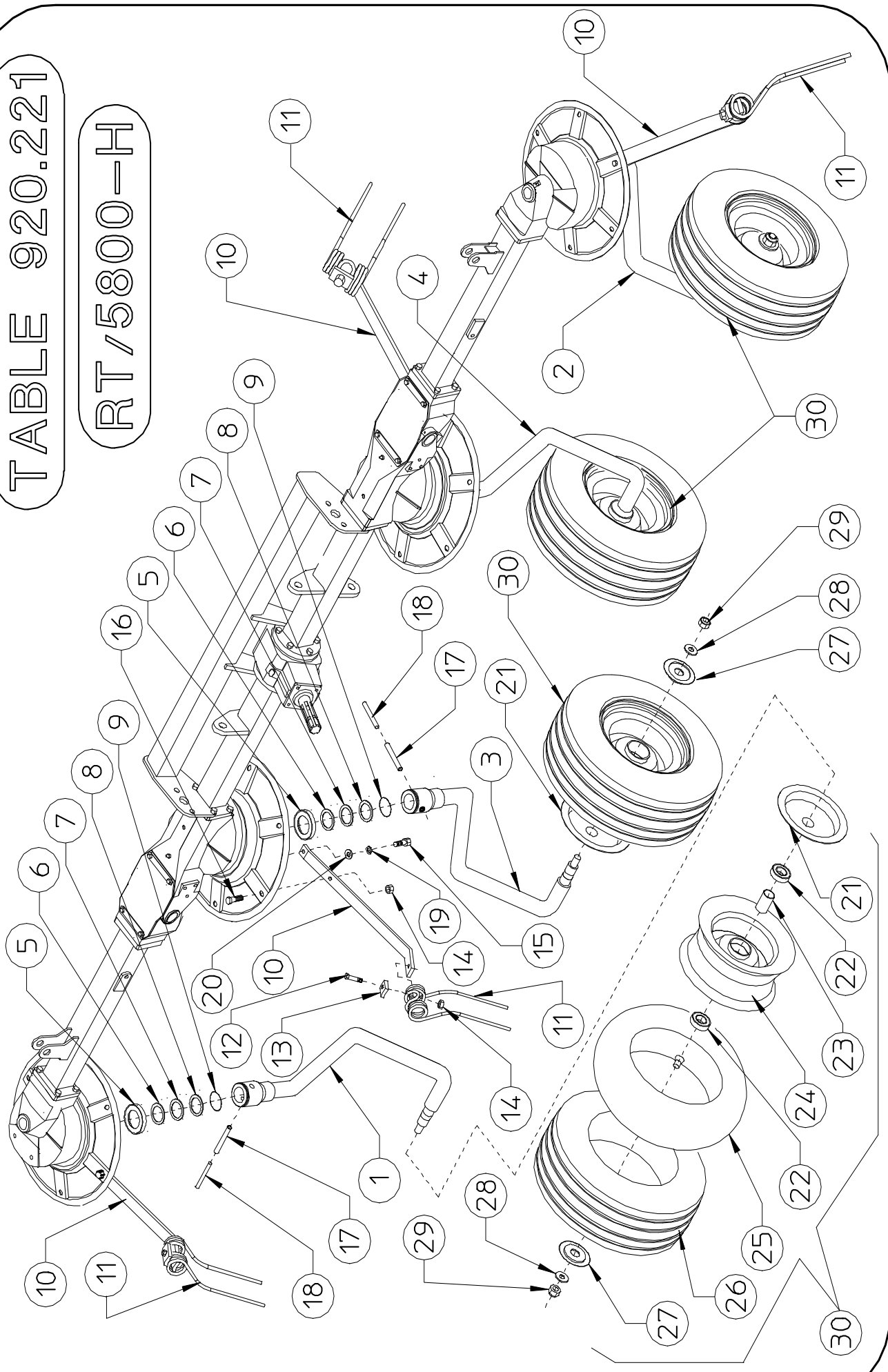

RT/5800-H -TABLE PART NO 920.221				
ITEM	Q.ty	PART NO	DESCRIPTION	NOTE
1	1	210.590	RH LATERAL SUPPORT	
2	1	210.591	LH LATERAL SUPPORT	
3	1	210.592	RH CENTER SUPPORT	
4	1	210.593	LH CENTER SUPPORT	
5	4	220.970	SPACER	
6	4*	200.419	SHIM (ø35,2/51,8x1)	*Q.ty as required
7	4*	200.274	SHIM (ø35,2/48x0,5)	*Q.ty as required
8	4*	200.490	SHIM (ø35,2/51,8x0,3)	*Q.ty as required
9	4	600.568	GASKET (OR 47,63x3,53)	
10	24	220.835	ARM	
11	24	210.574	TINE	
12	24	600.688	SCREW (M12x45-5737 ZN)	
13	24	200.402	PLATE	
14	48	600.077	NUT (M12-DIN 980)	
15	24	610.962	SCREW (M12x30-5739 ZN)	
16	24	600.616	SCREW (M12x35-5739 ZN)	
17	4	600.541	SPRING PIN (ø10x55-6873)	
18	4	600.562	SPRING PIN (ø6x55-6873)	
19	24	600.018	SPRING WASHER (ø13 ZN)	
20	24	220.864	WASHER (ø12,3/28,5x3)	
21	4	210.596	DUST COVER, INNER	
22	8	600.602	BEARING (6205 2RS)	
23	4	200.415	SPACER	
24	4	610.273	RIM	
25	4	610.274	TUBE	
26	4	610.275	TIRE	
27	4	200.416	DUST COVER, OUTER	
28	4	600.031	WASHER (ø17 ZN)	
29	4	600.080	NUT (M16-DIN 980)	
30	4	610.272	TIRE ASSY (16x6,50-8 6PLY)	

CARDAN SHAFT B3 150E A60792 + LW4
PART NO. 620.356
RT/5800-H PULL TYPE

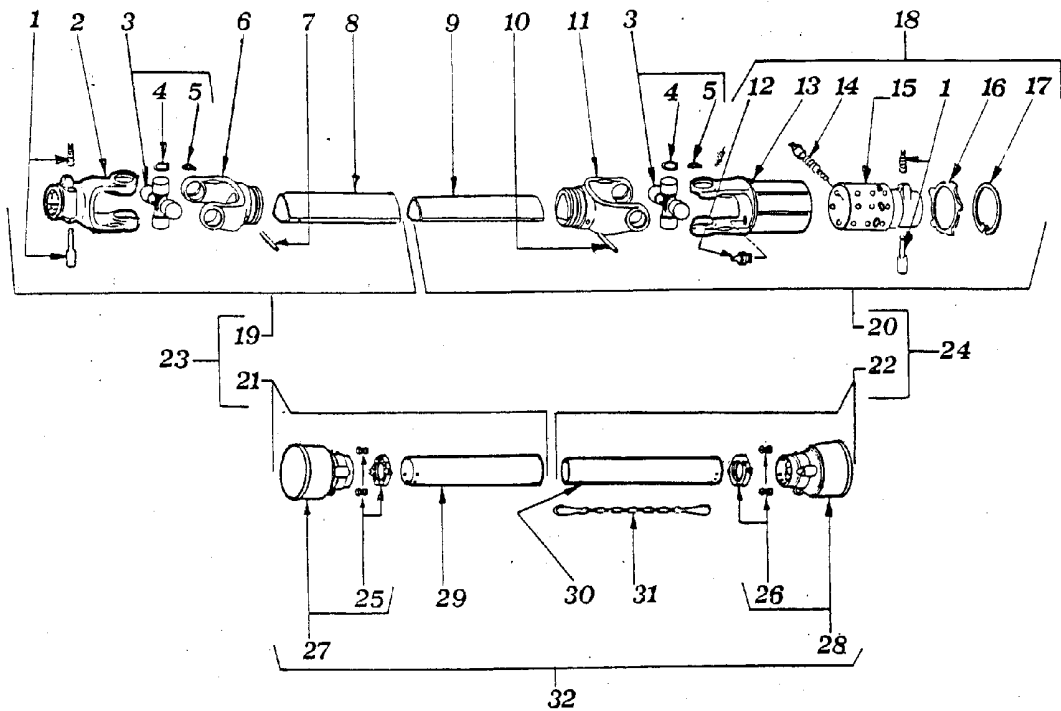

ITEM	PART NO	Q.ty	DESCRIPTION	NOTE
1	610.057	2	COMPLETE PUSH BUTTON	
2	610.234	1	YOKE	
3	610.235	2	CROSS JOURNAL ASS.	
4	610.205	8	CIRCLIP	
5	610.206	2	GREASE NIPPLE	
6	610.236	1	OUTER TUBE YOKE	
7	610.208	1	FLEXIBLE PIN	
8	610.209	1	CM 100 CARDAN TUBE (1 mt)	
9	610.210	1	CM.100 CARDAN TUBE (1 mt)	
10	610.211	1	FLEXIBLE PIN	
11	610.238	1	INNER TUBE YOKE	
12	610.216	1	GREASE NIPPLE	
13	620.631	1	OUTER CASING WITH YOKE	
14	610.218	32	RATCHET TOOTH	
15	620.635	1	HUB	
16	610.220	1	REATING WASHER	
17	610.221	1	CIRCLIP	
18	620.630	1	TORQUE LW4 x 03	
19	620.660	1	HALF SHAFT (WITHOUT GUARD)	
20	620.661	1	HALF SHAFT (WITHOUT GUARD)	
21	620.291	1	HALF SAFETY GUARD	
22	620.292	1	HALF SAFETY GUARD	
23	620.293	1	HALF SHAFT (WITH GUARD)	
24	620.662	1	HALF SHAFT (WITH GUARD)	
25	620.337	1	O. BEARING	
26	620.337	1	I. BEARING	
27	610.080	1	O. BASIC CONE	
28	610.081	1	I. BASIC CONE	
29	620.415	1	SAFETY TUBE	
30	620.416	1	SAFETY TUBE	
31	610.068	1	CHAINE	
32	620.663	1	SAFETY GUARD	

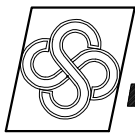

AGRICULTURAL MACHINERY
sitrex® Spa .

Zona Industriale-Viale Grecia, 8
06018 TRESTINA-(Perugia)-ITALY
Tel. +39.075.8540021-Telefax +39.075.8540523
e-mail: sitrex@sitrex.it www.sitrex.com

