



AGRICULTURAL MACHINERY

sitrex®
Spa

ASSEMBLY, USE AND MAINTENANCE SPARE PARTS LIST

RT/2500-RT/3000

PULL TYPE AND 3rd POINT HITCH

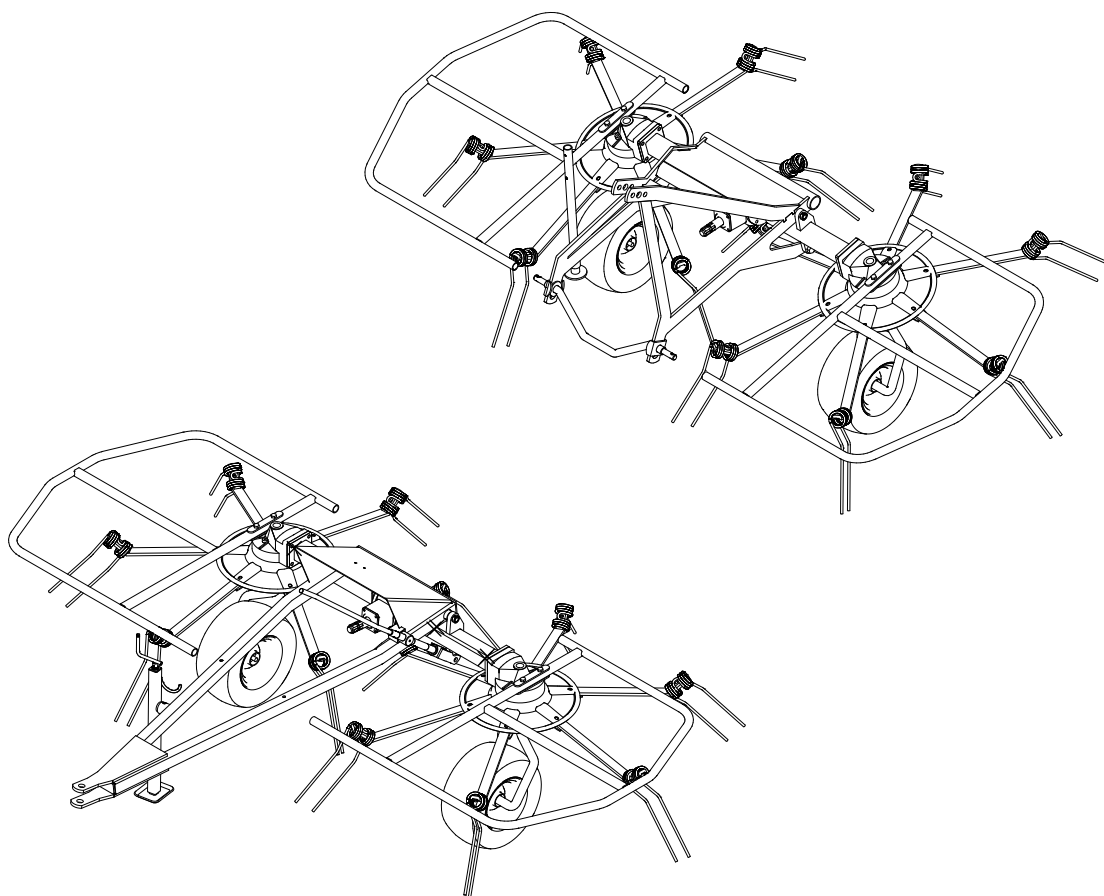

ROTARY TEDDER

09/16

WARRANTY

On delivery, check that the machine has not been damaged during transport and that all the attachments are present. Claims must be made in writing to the agent within 8 days of receipt.

The manufacturer warrants new machinery at the time of delivery to the original purchaser to be free from defects in material and workmanship if properly set up and operated in accordance with this Operator's Manual.

The manufacturer undertakes to repair or replace free of charge any defective part which should be returned by the purchaser (freight prepaid) and found to be defective by inspection authorized by the manufacturer during the warranty period.

This warranty will be valid for 12 (twelve) months from the delivery of goods to the original purchaser .

In case the customer is not in a position to return the defective part to the manufacturer , the manufacturer cannot be held responsible for any cost due for repair or replacement of any part of the machine , he will only supply the part(s) required for the repair and/or replacement.

The warranty is null and void when it is evident that the machine has been improperly used or however repaired without authorization.

The manufacturer undertakes no responsibility for any obligation or agreement reached by any employers, agents or dealers, which are not in compliance with the above warranty . The manufacturer cannot be held responsible for the consequent damages. This warranty substitutes any other warranty , express or implied , and any other manufacturer's obligation.

CHAPTER

- 1) GUIDE TO THE SIGNS
- 2) **General summary of safety and accident-prevention instructions**
- 3) **PRODUCT IDENTIFICATION**
- 4) **DELIVERY AND ASSEMBLY**
- 5) **ADJUSTMENT, PREPARATION AND USE**
- 6) **MAINTENANCE**
- 7) **SPARE PARTS LIST**

1) GUIDE TO THE SIGNS AND SYMBOLS USED ON THE MACHINE

IMPORTANT

These signs and symbols give information to the operator on how to make the best use of the machine so as to prolong life, avoid damage, optimise work and, above all, to avoid injury to the operator and anyone within range of the machine.

WARNING SIGNS

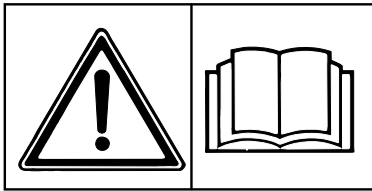

1) Before beginning operations, read the instruction manual carefully.

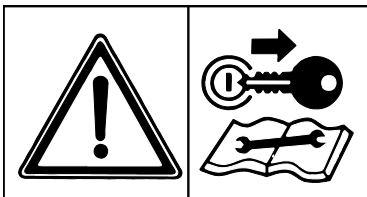

2) Before doing any maintenance or repair work, stop the machine at a suitable spot. Turn off the tractor motor, apply the brake, remove the key from the ignition and consult this manual.

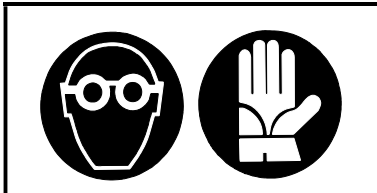

3) This is a warning to use proper accident protection when carrying out maintenance and repairs

DANGER SIGNS

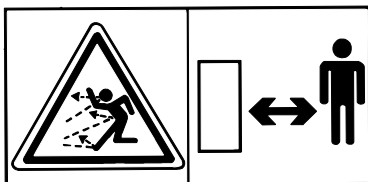

4) Risk of possible ejection of blunt objects. Keep a safe distance from the machine

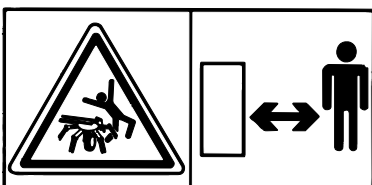

5) Indicates that anyone coming within range of the moving tine arms will be seriously injured. Keep a safe distance from the machine.



6) Indicates that there is a risk of crushing your hands. Keep your distance.

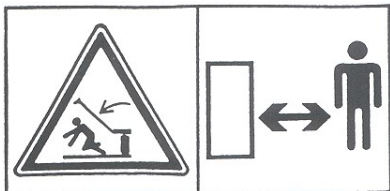

7) Indicates danger caused by accidental fall of suspended arms. Keep safe distance.



8) Indicates that it is dangerous to touch the cardan (P.T.O.) shaft. For all the other information regarding the cardan shaft, see the use and maintenance booklet specifically for the cardan shaft which, together with this manual, makes up the documentation on safety, use and maintenance of the machine.

INDICATION SIGNS



9) Indicates a greasing point.



10) Shows the direction of rotation of the power takeoff and the maximum number revolutions.

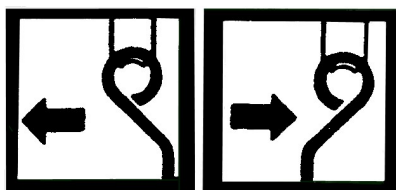

11) Indicates position of the tines on the rotors and their direction of rotation.

GENERAL SUMMARY OF SAFETY AND ACCIDENT PREVENTION INSTRUCTIONS

Read all the instructions carefully before using the machine. When in doubt seek advice from the manufacturing company.

The manufacturing company declines all responsibility for non-compliance with the following safety and accident prevention instructions.

- 1. Pay attention to the danger signs and symbols in this manual and on the machine.**
- 2. Do not touch moving parts.**
- 3. All work on the machine (including adjustment) must always be carried out with the tractor immobilized and the engine switched off.**
- 4. On no account may persons or animals be carried on the machine.**
- 5. Driving the tractor with the machine connected is absolutely forbidden to persons lacking suitable experience, or who are in poor health, or who are too young or do not have a suitable driving licence if travelling on the highway.**
- 6. All accident prevention measures recommended in this manual should be scrupulously observed.**
- 7. Connecting the machine to the tractor creates a different weight distribution on the tractor axles and so it is essential to ensure that the tractor-machine combination is stable in all anticipated working condition. It is therefore necessary to have exact instructions from the tractor manufacturers. If such instructions are not available, suitable tests should be conducted in safe conditions in order to assess stability.**
- 8. Once the machine is connected it can only be controlled through a Cardan (P.T.O.) shaft complete with the required overload protection and guard secured with the appropriate small chains. Be aware of the rotational direction of the Cardan (P.T.O.) shaft.**
- 9. Before operating the tractor and machine, check that all transport and operational safety devices are complete and working.**
- 10. When driving on public roads, you should comply with the highway code regulations for the country concerned.**
- 11. Do not exceed the tractor axle maximum weight and the total mobile weight.**
- 12. Before starting work, familiarize yourself with the control devices and how they work.**
- 13. Wear suitable clothes. Do not wear clothing which is loose or which could become entangled in rotating or moving parts.**
- 14. Connect the machine to a suitably powerful tractor by using an appropriate lifting unit and in accordance with instructions.**
- 15. Take maximum care when connecting and disconnecting the machine to and from the tractor.**
- 16. The machine and any road transport attachments must bear the appropriate signs and symbols and have suitable protections.**
- 17. Never leave the driving seat when the tractor is running.**

18. It is extremely important to appreciate that road-holding, steering and braking may be significantly affected with the machine attached.
19. When turning corners with the machine attached, be aware of the fact that the centrifugal force will alter due to the change in the centre of gravity.
20. Before engaging the power takeoff, check the pre-set revolution speed, **MAXIMUM 540rpm**. Do not use 1000rpm drive.
21. Under no circumstances should anybody stand near the machine or any moving parts. It is the duty of the operator to ensure that this requirement is respected.
22. Before leaving the tractor, lower the machine with the lifting unit, stop the engine, apply the parking brake and remove the ignition key from the instrument panel.
23. Under no circumstances should anybody go between the tractor and the machine (fig.1) when the engine is running and the Cardan (P.T.O.) shaft is engaged, especially without first having applied the parking brake and placed chocks against the wheels.
24. Before connecting or disconnecting the machine to or from the 3-point linkage, put the lifting unit lever into the locked position.
25. The connection pins on the machine must match the connection sockets on the lifting unit.
26. During transport, stop machine sway, secure the lower lift arms with the stabilisers or check chains.
27. When the machine is raised during road transport, put the tractor's hydraulic lift control lever into the locked position.
28. Only use the Cardan (P.T.O.) shaft provided by the manufacturer and, in case of replacement, substitute it with one having the same characteristics.
29. Regularly check all protection guards on the Cardan (P.T.O.) shaft. These should always be in excellent condition and securely fixed.
30. It is important to ensure that the protection on the Cardan (P.T.O.) shaft is complete.
31. Connection and disconnection of the Cardan (P.T.O.) shaft must be carried out with the engine stopped and switched off.
32. Pay particular attention to the correct connection and safety of the power takeoffs on the machine and the tractor.

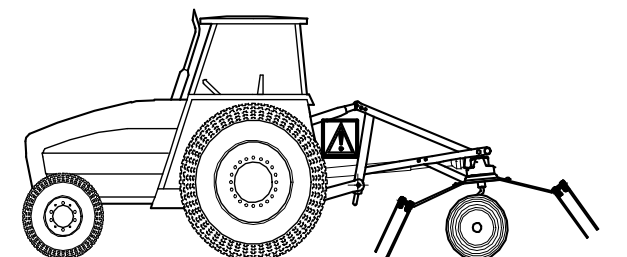
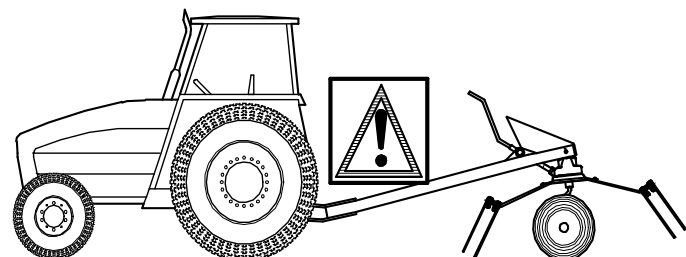

- 33. Prevent the cardan (P.T.O.) shaft protection from rotating using the chains supplied.
- 34. Before engaging the power takeoff, make sure that there are no people or animals in the vicinity and that the selected engine speed corresponds to the Cardan (P.T.O.) speed permitted 540rpm MAXIMUM.
- 35. Do not engage the power take-off when the engine is not running.
- 36. Always disengage the power take-off when the Cardan (P.T.O.) shaft is at too wide an angle (it should never be more than 35° - fig.2) and when it is not in use.

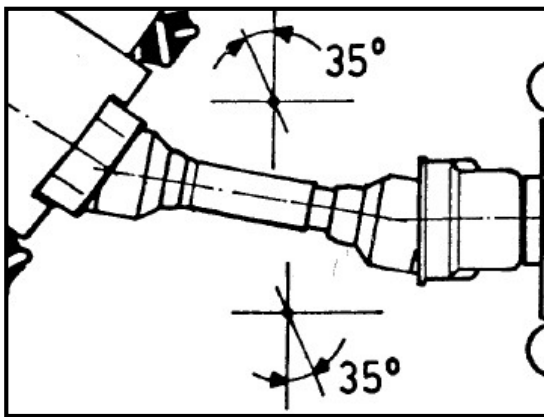

Fig.2

- 37. Only clean and grease the Cardan (P.T.O.) shaft when the power takeoff is disengaged, the engine is off, the parking brake is applied and the ignition key is removed.
- 38. When the Cardan (P.T.O.) shaft is not in use, rest it on the support provided.
- 39. On disconnecting the Cardan (P.T.O.) shaft, replace the protective cover on the power input (gearbox) shaft.

- 40. Prolonged use of the machine can cause the drive boxes (fig.4) to become hot. To avoid any risk of getting burnt, avoid touching these areas both during use and sometime afterwards.
- 41. Periodically check screws and nuts for tightness and grip. Tighten as necessary.
- 42. When the machine is raised for maintenance work and tine replacement, put suitable supports under the machine as a safety precaution.
- 43. Ensure that the recommended grease is used.
- 44. Spare parts must meet the requirements as defined by the manufacturer. Use only original spare parts.
- 45. Safety decals must always be clearly visible. They must be kept clean and replaced if they become too illegible (they can be ordered from the dealer if necessary).
- 46. The instruction booklet must be available to all users for the lifetime of the machine.

3) PRODUCT IDENTIFICATION

RT/2500-RT/3000 PULL TYPE

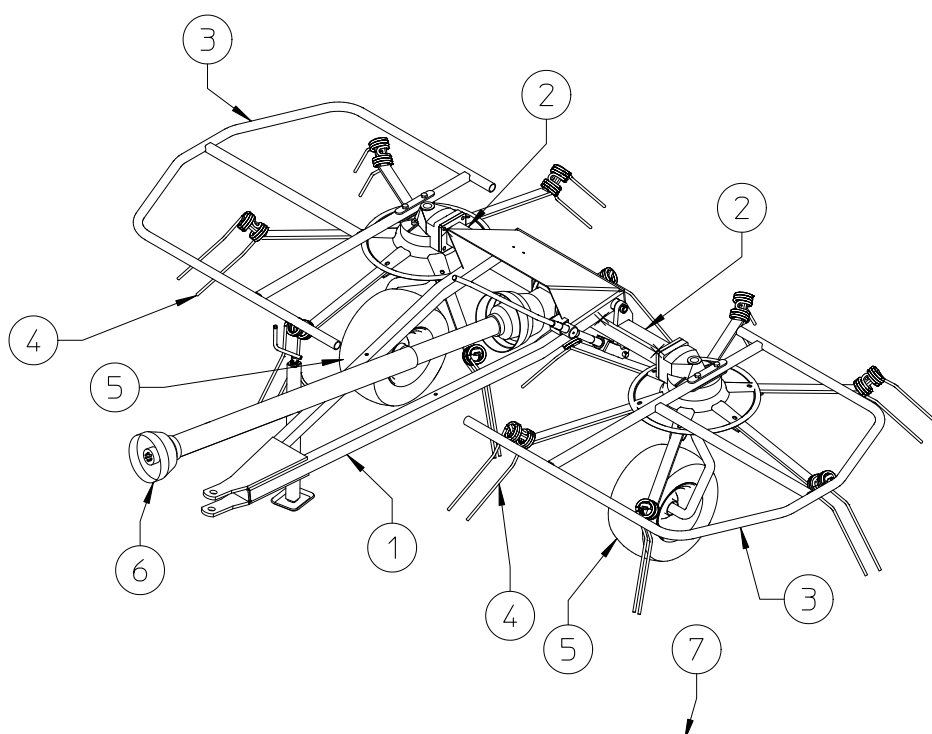

MAIN PARTS

- 1) DRAWBAR
- 2) RH AND LH ROTORS
- 3) RH AND LH GUARD
- 4) RH AND LH TINE ARM
- 5) WHEEL ASSEMBLY
- 6) CARDAN SHAFT
- 7) IDENTIFICATION PLATE



TECHNICAL DATA

SPECIFICATIONS	RT/2500 PULL TYPE	RT/3000 PULL TYPE
Number of rotors	2	2
Tine arms per rotor	6	6
Working width	8' 3" (2,52 m)	10' (3,05 m)
Transport width	7' 3" (2,2 m)	8' 9" (2,67 m)
Weight	360 lbs (165 kg)	385 lbs (175 kg)
Tire	16x6.50-8	16x6.50-8
PTO Tractor requirement	14 hp (10 kw)	15 hp (11 kw)
PTO slip clutch	Standard	Standard
Operating speed	10 mph (16 Km/h)	10 mph (16 Km/h)

All data are indicative. Sitrex reserves the right to change them without advance notice.

3) PRODUCT IDENTIFICATION

RT/2500-RT/3000 3rd POINT HITCH

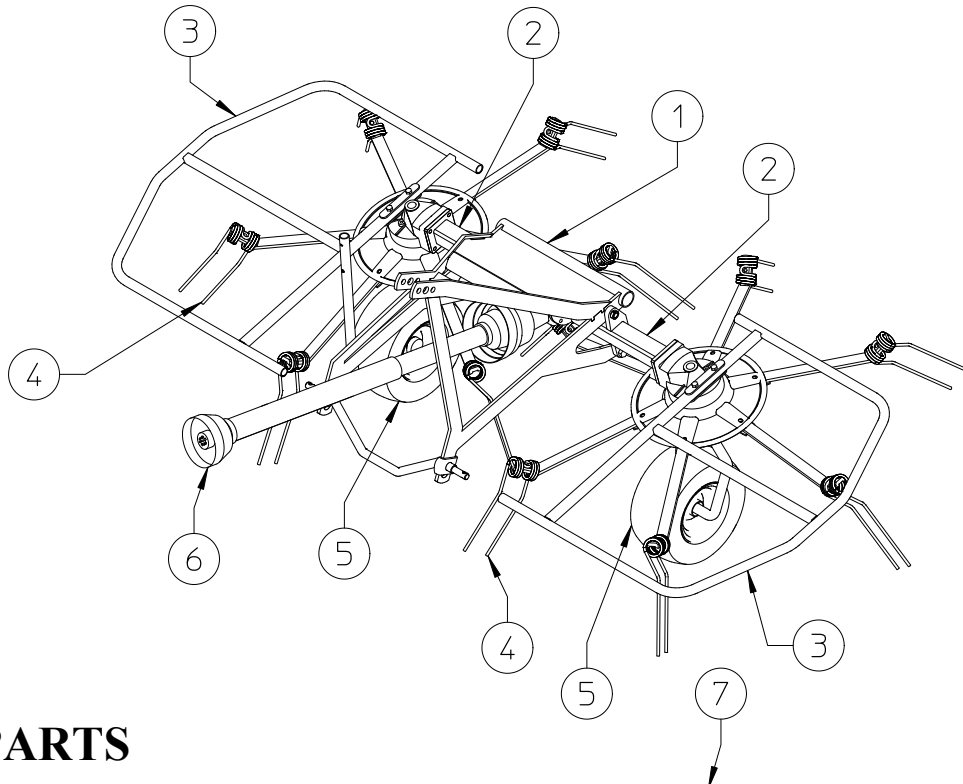

MAIN PARTS

- 1) 3rd POINT HITCH
- 2) RH AND LH ROTORS
- 3) RH AND LH GUARD
- 4) RH AND LH TINE ARM
- 5) WHEEL ASSEMBLY
- 6) CARDAN SHAFT
- 7) IDENTIFICATION PLATE



TECHNICAL DATA

SPECIFICATIONS	RT/2500 3 rd point hitch	RT/3000 3 rd point hitch
Number of rotors	2	2
Tine arms per rotor	6	6
Working width	8' 3" (2,52 m)	10' (3,05 m)
Transport width	7' 3" (2,2 m)	8' 9" (2,67 m)
Weight	360 lbs (165 kg)	385 lbs (175 kg)
Tire	16x6.50-8	16x6.50-8
PTO Tractor requirement	14 hp (10 kw)	15 hp (11 kw)
PTO slip clutch	Standard	Standard
Operating speed	10 mph (16 Km/h)	10 mph (16 Km/h)

All data are indicative. Sitrex reserves the right to change them without advance notice.

4) DELIVERY AND ASSEMBLY

Checking the machine on delivery

All parts are carefully checked before dispatch or delivery.

On receiving the machine, ensure that it has not been damaged during transport. If damage has occurred, contact the dealer concerned.

Details of packing are given below.

UNPACKING THE MACHINE



DANGER !!!



Lift the machine using a forklift truck, crane or other suitable equipment of sufficient capacity after first checking the weight of the configurations in the table given below.

Check the stability and positioning of the load on the forklift truck forks or crane hook.

Keep the load as low as possible during movement for maximum stability and to ensure that the operator has maximum visibility.

If a forklift truck is used, ensure that the forks are positioned as wide apart as possible.

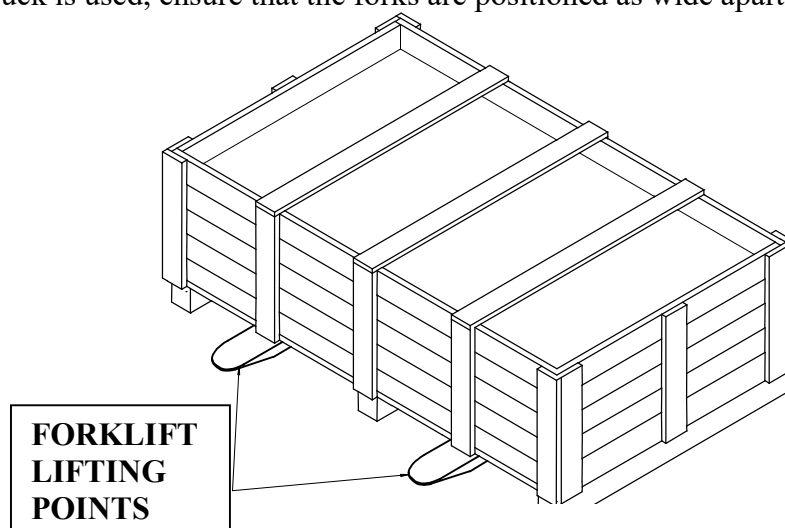

MACHINE	WEIGHT PACKING KG/LBS	WEIGHT KG/LBS
RT/2500 pull type	210/460	165/360
RT/3000 pull type	220/485	175/385
RT/2500 3 rd point hitch	210/460	165/360
RT/3000 3 rd point hitch	220/485	175/385

NOTE:

- 1) The packing consists mainly of wood, which should be disposed of according to the laws in force in the country where the machine is used. The plastic film should also be disposed of according to the laws in force in the country where the machine is used.
- 2) When storing, it is permissible to stack 2-3 crates on top of each other. Make sure that they are perfectly aligned cortically.
- 3) In the event of further transport, ensure that the machine when on the transporting vehicle.

ASSEMBLY INSTRUCTIONS

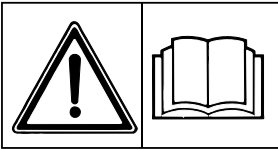

DANGER !!!



Assembly is highly dangerous and must be carried out in strict accordance with the following instructions. We recommend that qualified personnel perform assembly. We also recommend that assembly be carried out in a flat, solid surface, open area with no people (particularly children) nearby who could be severely injured if they were to touch or move any parts of the machine.

Assemblers must provide suitable lifting mechanisms and supports for stabilizing the partially assembled units, so as to prevent them from falling and causing damage or injury. The steps for assembly are illustrated in following. Depending on the experience of the assemblers and the tools available, it is not necessary that the instructions be followed in the exact order given here, but the safety precautions described above must always be followed carefully and scrupulously.

ASSEMBLY SEQUENCE:

SUPPORTS AND WHEELS ASSEMBLY (RT-2500/RT-3000 PULL TYPE)

1) To facilitate the assembly of the wheel supports, we advise that you turn the machine body upside-down.
USE MAXIMUM CAUTION.

2) Before going on with assembly, be sure that hole “A” of rotor 1 is at the centre of holes “B” of rotor 2, as you can see on the drawing.

3) Attach the large hay guards 5 to wheel supports 3-4, followed by wheels 6, small hay guards 7, washers 8 and fasten with nuts 9.

In this steps, you will use:

Item 8: 2 flat washers $\varnothing 17$ (0.67")

Item 9: 2 nuts M16

Continued on next page.

Continued from previous page

RT2500/RT3000 PULL TYPE

SUPPORTS AND WHEELS ASSEMBLY

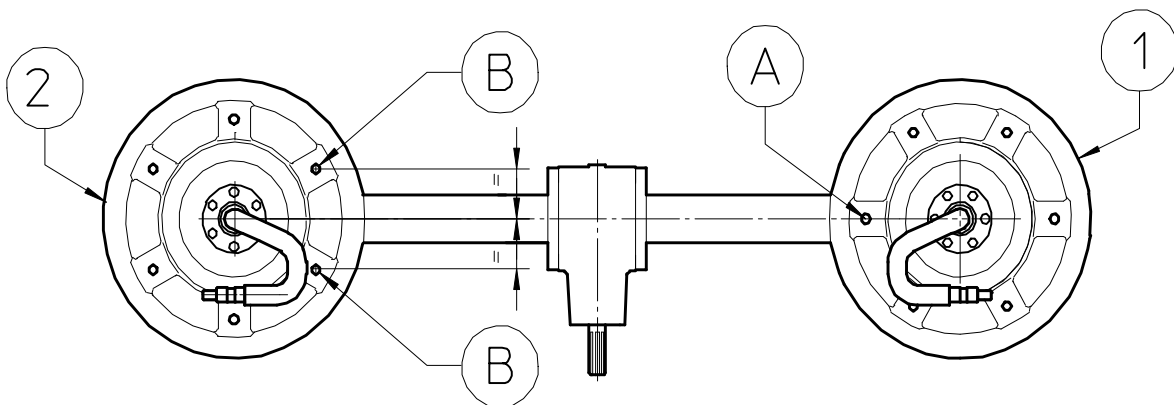
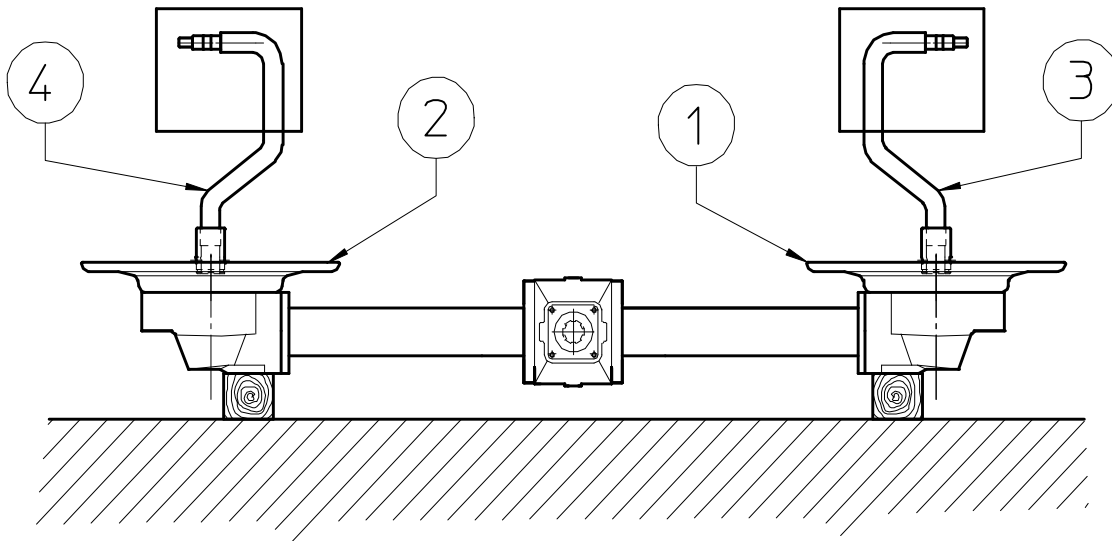
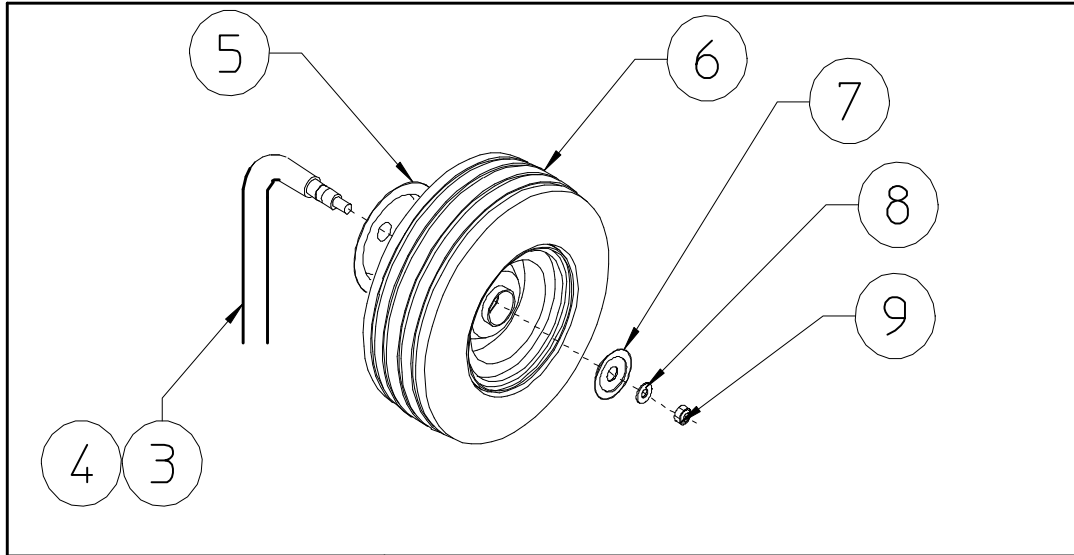

ASSEMBLING STEPS

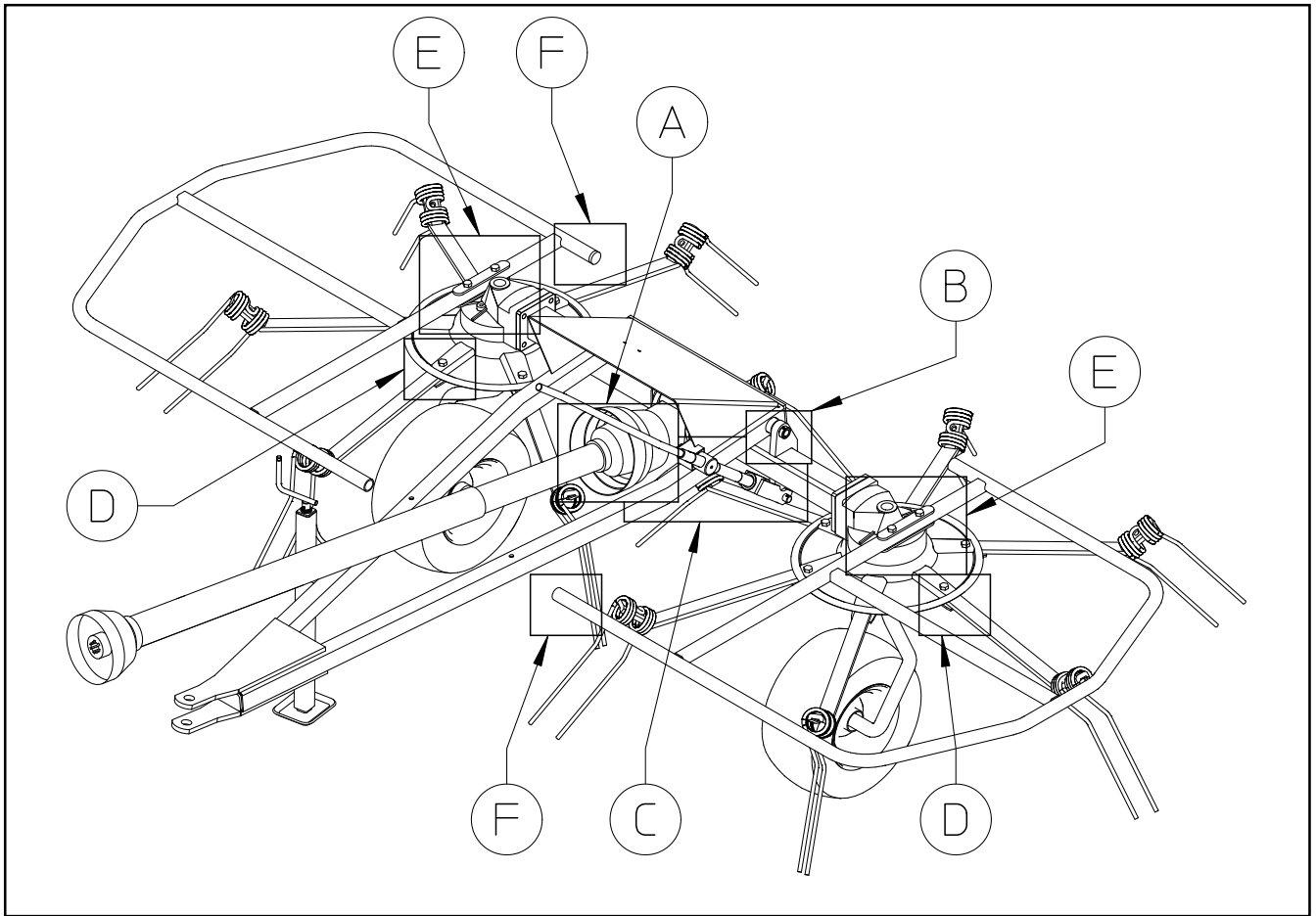

STEP "A"

Attach guard 1 to the central gear box 2 using nuts 3.

In this step, you will use:
Item 3 : 2 nuts M8

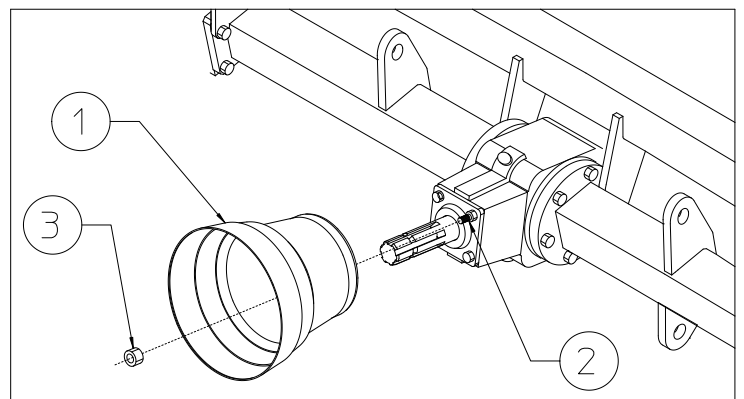

STEP "B"

Attach drawbar 1 to the machine body 2 with pin 3 into the holes 4 of the machine body 2 and drawbar 1. Fasten pin 3 with bush 5 and split pins 6.

In this step, you will use:

Item 5 : 2 bush $\varnothing 20,5/30 \times 12$
($\varnothing 0.8''/1,2'' \times 0,47$)

Item 6 : 2 split pins $\varnothing 5 \times 40$
($\varnothing 0.2'' \times 1.57''$)

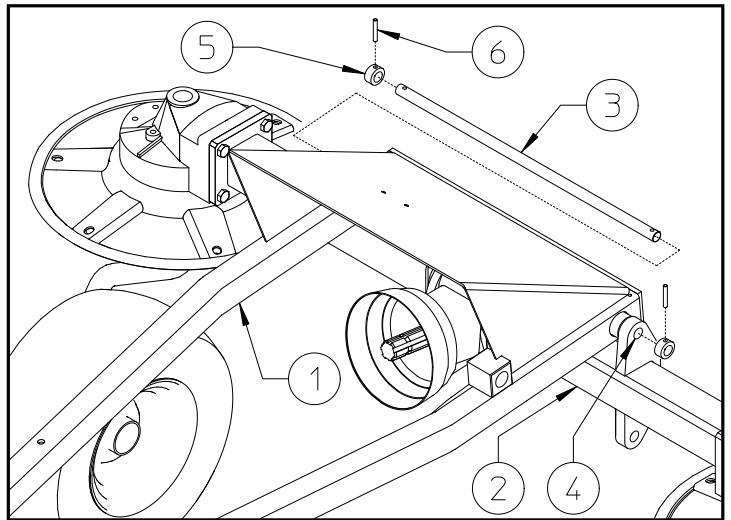

STEP "C"

Attach grease nipples 1 to the pin and fork of the crank assembly 2. Insert the pin of crank assembly 2 into its seat in drawbar 3, inserting the spacers 4. Fasten in place with split pin 5. Fasten the fork of the crank assembly 2 at hole 6 using pin 7 and split pins 5.

In this step, you will use:

Item 1 : 3 grease nipples M6

Item 4 : 2 shims $\varnothing 30.5 \times 39.8 \times 1$
($\varnothing 1.2'' \times 1.57'' \times 0.04''$)

Item 5 : 3 split pins $\varnothing 5 \times 40$
($\varnothing 0.2'' \times 1.57''$)

Item 7 : 1 pin $\varnothing 20 \times 66$ ($\varnothing 0.79'' \times 2.6''$)

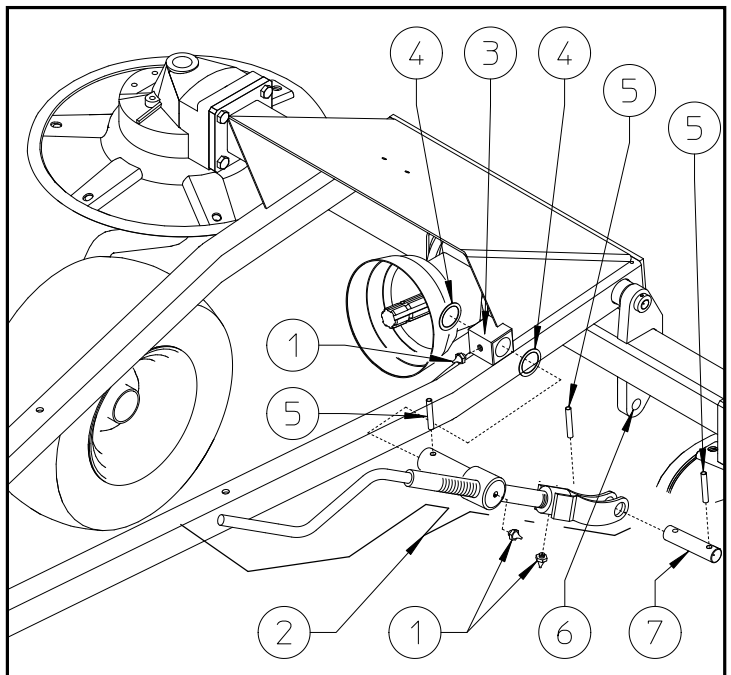

STEP "D"

You will find tine bars 1 (RH) and 2 (LH) in two bundles (one RH and one LH) of six pieces each. Continued on next page.

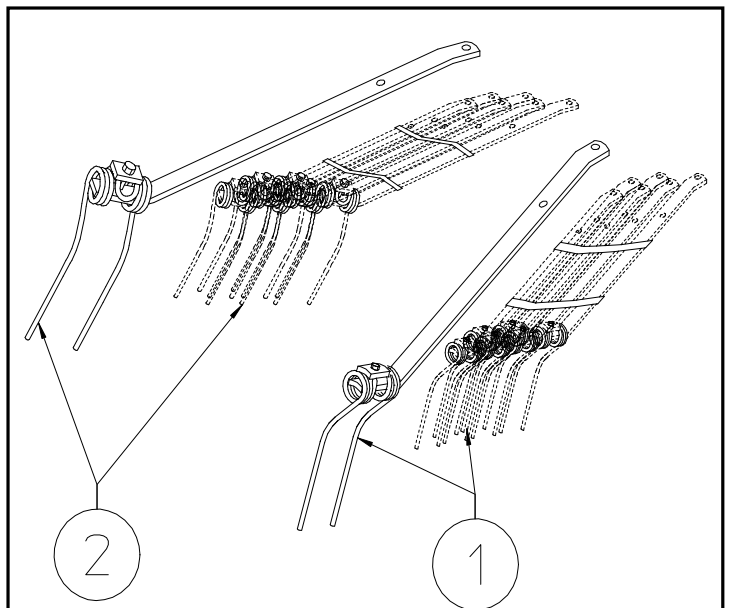

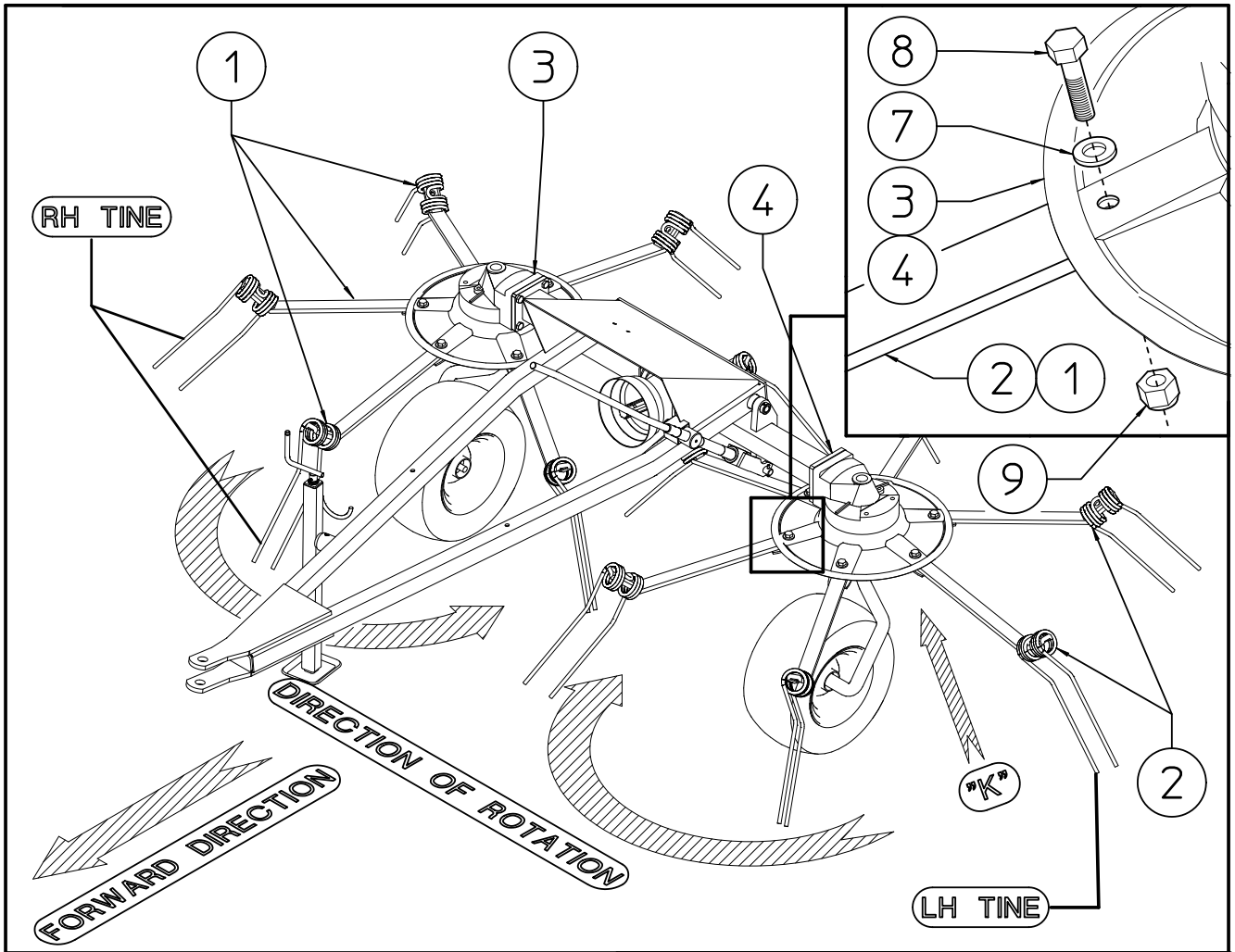

Continued from previous page.

STEP "D"

Tine bars 1 (RH) are attached to rotor 3.
 Tine bars 2 (LH) are attached to rotor 4.
 Attach tine bars 1 (RH) and 2 (LH) to
 respective rotor 3 (RH) and 4 (LH)
 with screws 5, spring washers 6,
 washers 7, screws 8 and nuts 9.

In this step, you will use:

Item 5 : 12 screws M12x30
 (0.47"x1.18")

Item 6 : 12 spring washers $\phi 13$
 ($\phi 0.51$ ")

Item 7 : 24 washers $\phi 13$ ($\phi 0.51$ ")

Item 8 : 12 screws M12x40
 (0.47"x1.57")

Item 9 : 12 nuts M12

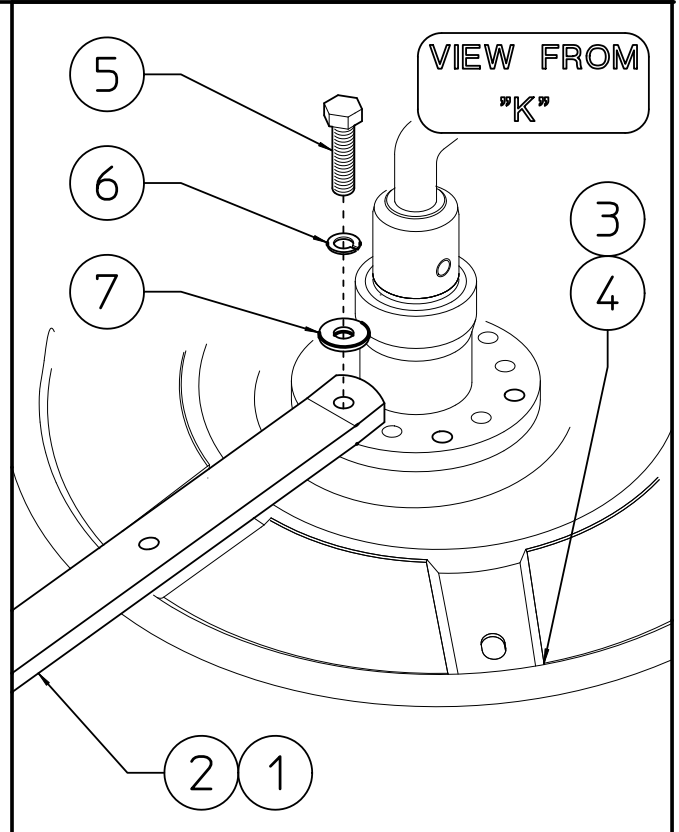

STEP “E”

Attach the lateral guard 1 and 2 (RH-LH) to machine body using screws 3 and washers 4. Attach grease nipples 5 in the proper holes.

In this step, you will use:

Item 3 : 4 screws M12x60 (0.47”x2,36”)

Item 4 : 4 washers $\varnothing 13$ ($\varnothing 0.51$ ”)

Item 5 : 2 grease nipples M10

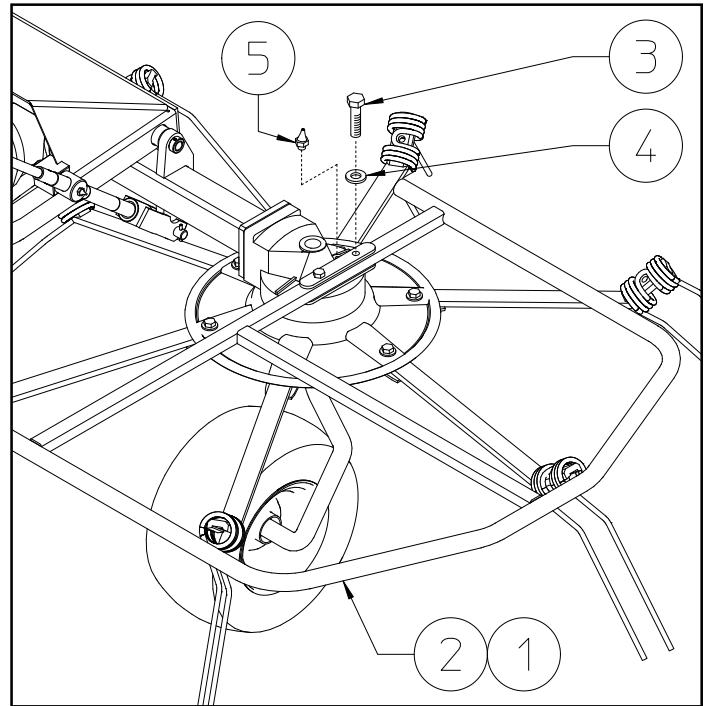

STEP “F”

Apply caps 3 to lateral guard 1-2 (RH-LH) .

In this step, you will use:

Item 3 : 4 caps $\varnothing 32$ ($\varnothing 1.25$ ”)

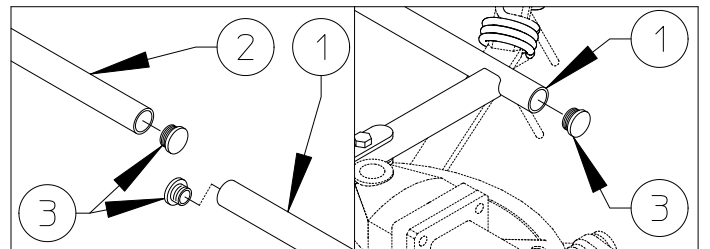

Assembly is now completed, and the machine should appear as shown in the illustration.

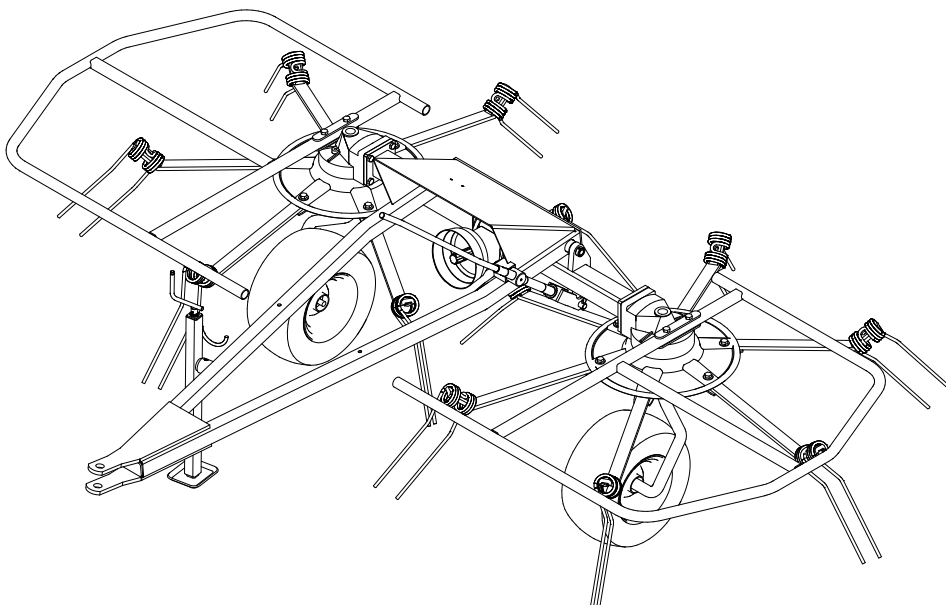

SUPPORTS AND WHEELS ASSEMBLY (RT-2500/RT-3000 3rd POINT HITCH)

USE MAXIMUM CAUTION.

- 1) Apply wheel supports 1-2 (RH-LH) to the corresponding hubs 3-4 (RH-LH) interposing shims 5-6. Finally fasten with pins 7.
- 2) Apply grease nipples 8 to the corresponding points of hubs 3-4 (RH-LH) .
- 3) Attach the large hay guards 9 to wheel supports 1-2 (RH-LH), followed by wheels 10, small hay guards 11, washers 12 and fasten with nuts 13.

In this steps, you will use:

- Item 5: 2 shims $\varnothing 30.3-39.8 \times 1$ (or 0.5) ($\varnothing 1.19''-1.57'' \times 0.04''$) (or 0.02'')
- Item 6: 2 shims $\varnothing 30.3-39.8 \times 0.5$ (or 1) ($\varnothing 1.19''-1.57'' \times 0.02''$) (or 0.04'')
- Item 7: 2 spring pins $\varnothing 6 \times 45$ ($\varnothing 0.24'' \times 1.77''$)
- Item 8: 2 grease nipples M6 (0.24'')
- Item 12: 2 flat washers $\varnothing 17$ ($\varnothing 0.67''$)
- Item 13: 2 nuts M16 (0.63'')

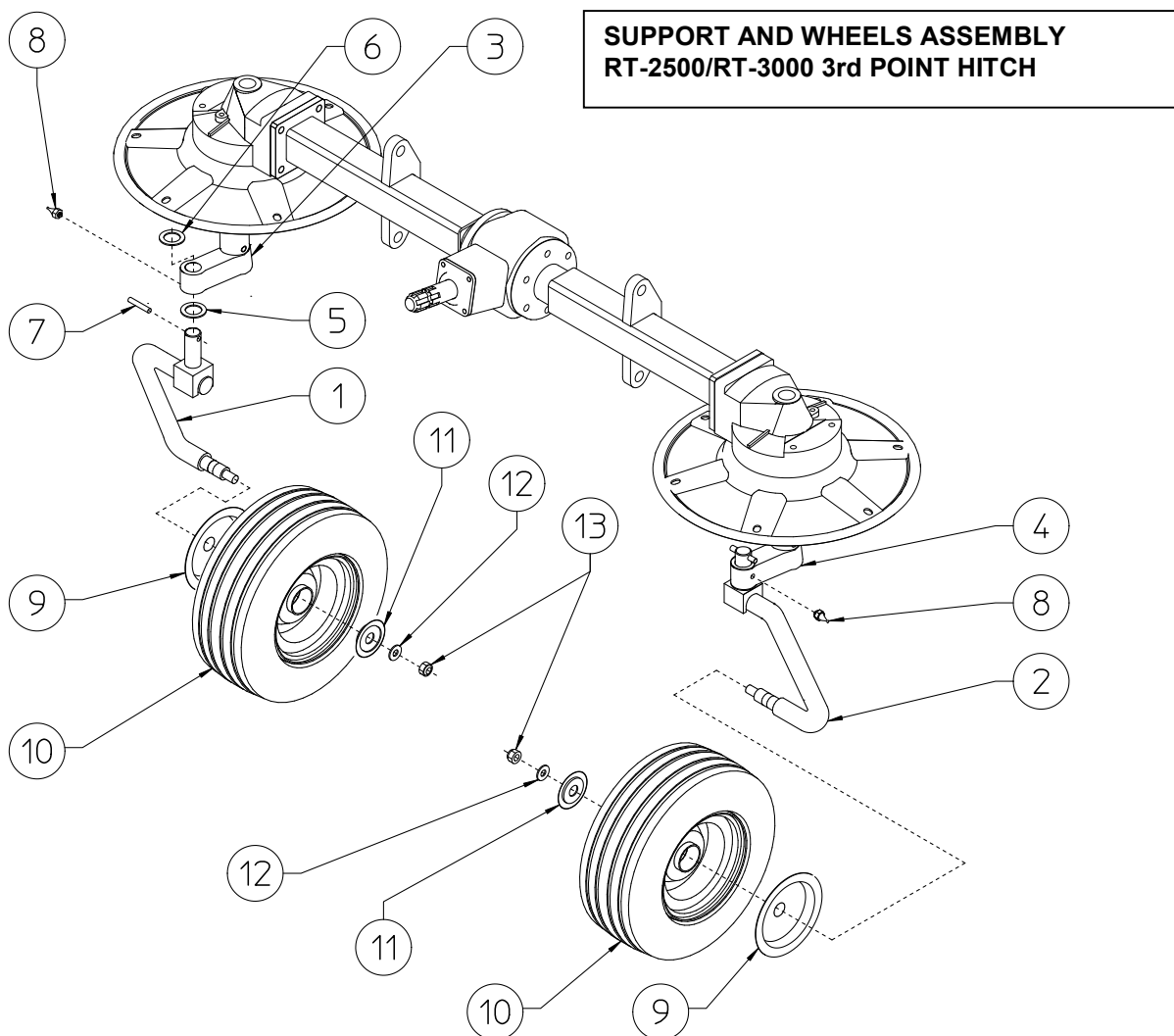

ASSEMBLING STEPS

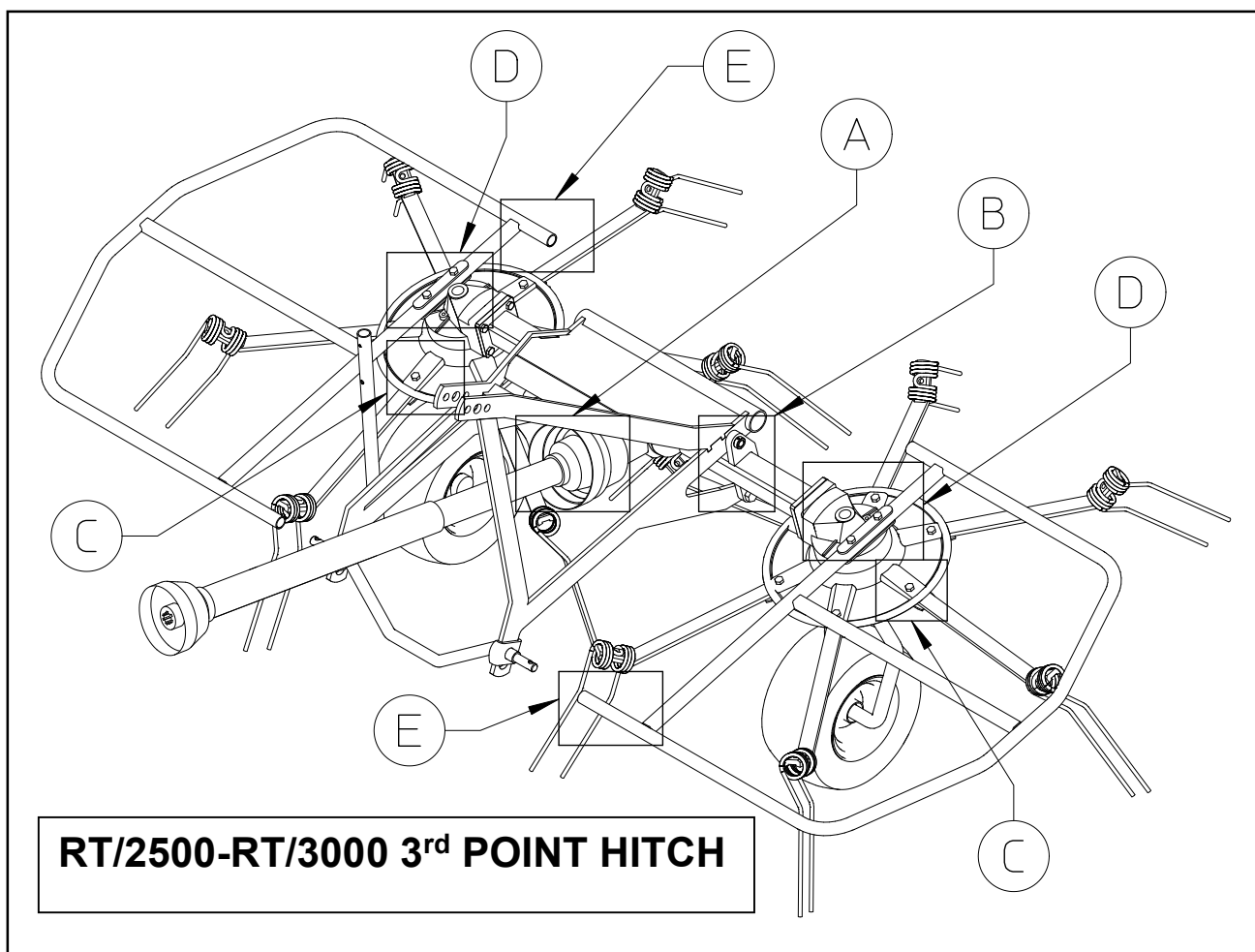

STEP "A"

Attach guard 1 to the central gear box 2 using nuts 3.

In this step, you will use:
Item 3 : 2 nuts M8

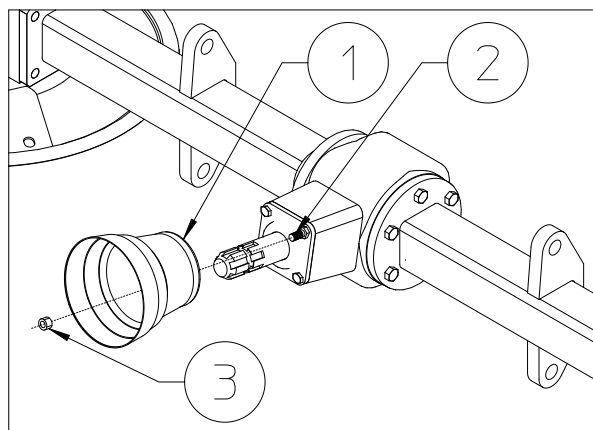

STEP "B"

Apply 3rd point hitch 1 to holes supports 2 through pin 3, bush 4 and split pins 5.

Apply 3rd point hitch 1 to holes supports 6 through screw 7 and nut 8.

In this step, you will use:

Item 4 : 2 bush $\varnothing 20,5/30 \times 12$

($\varnothing 0.8''/1,2'' \times 0,47''$)

Item 5 : 2 split pins $\varnothing 5 \times 40$

($\varnothing 0.2'' \times 1.57''$)

Item 7 : 2 screw M20x55

($0,78'' \times 2,16''$)

Item 8 : 2 nut M20 (0,78'')

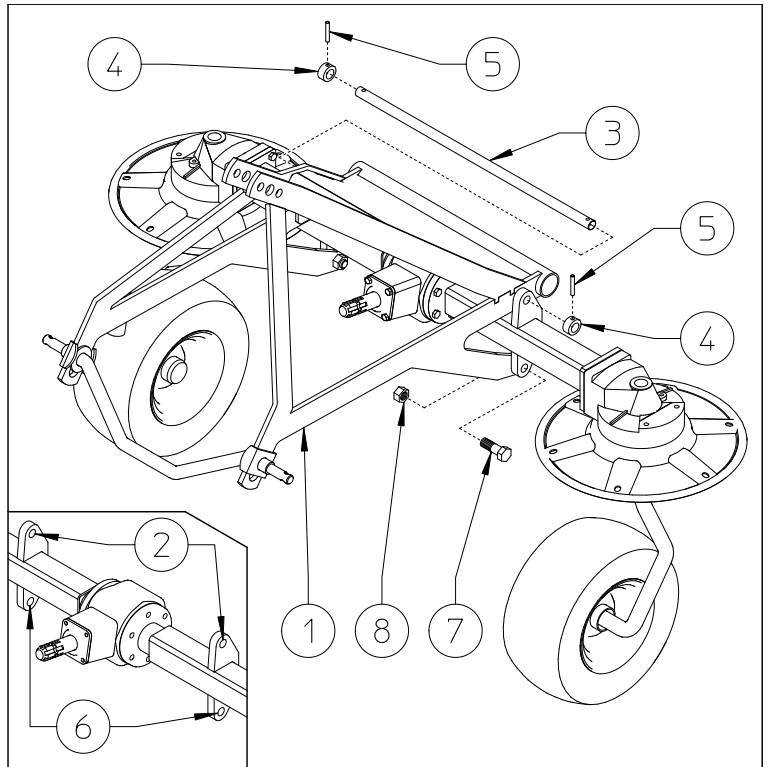

STEP "C"

You will find tine bars 1 (RH) and 2 (LH) in two bundles (one RH and one LH) of six pieces each.

Continued on next page.

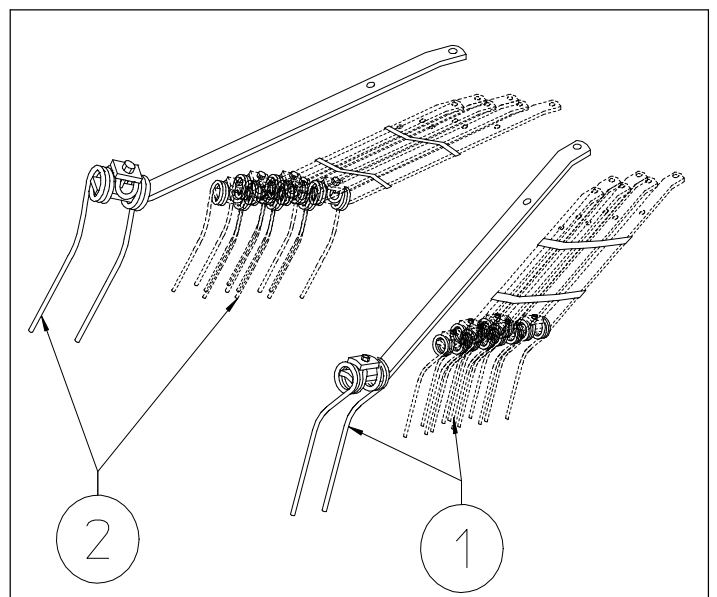

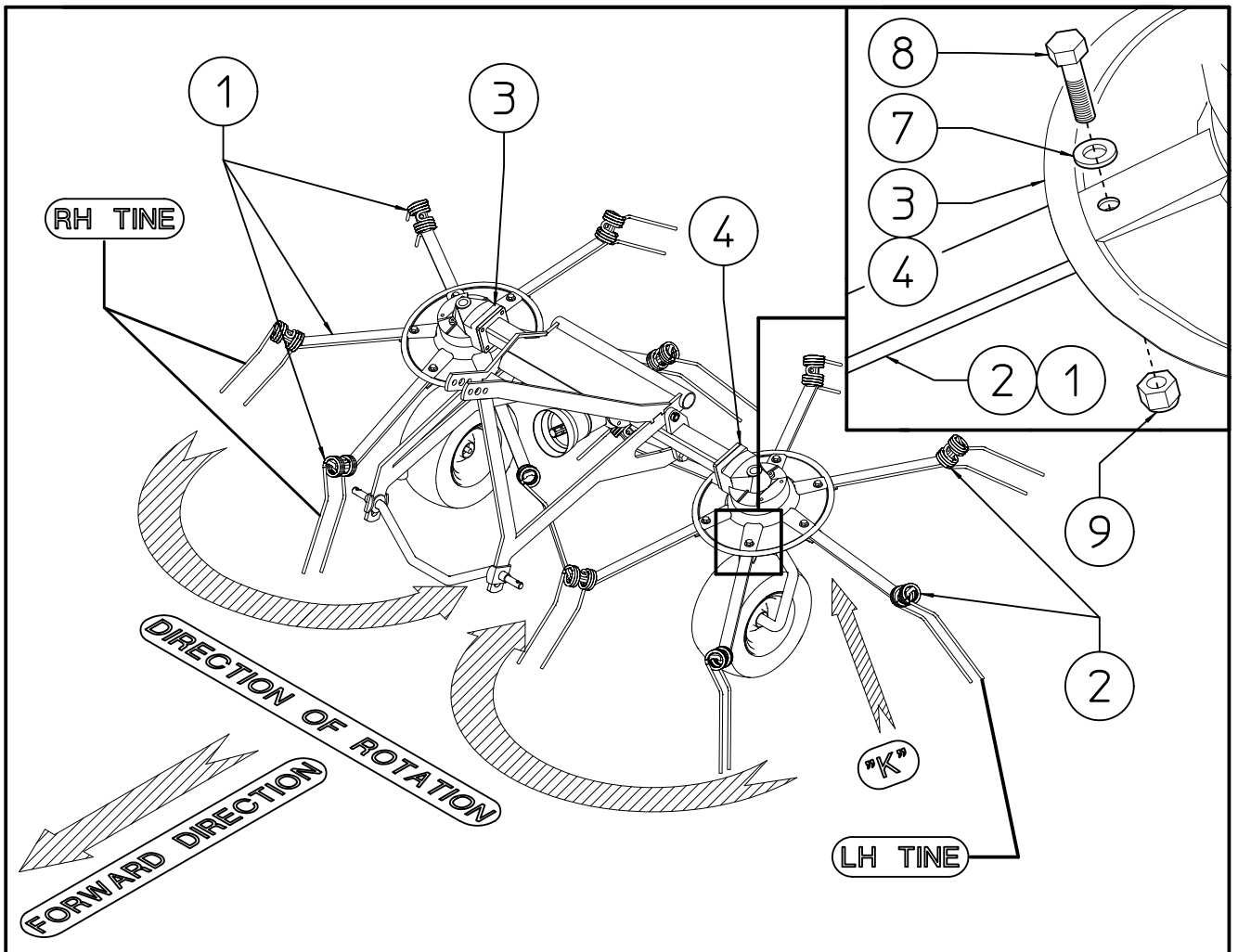

Continued from previous page

STEP "D"

Tine bars 1 (RH) are attached to rotor 3.
 Tine bars 2 (LH) are attached to rotor 4.
 Attach tine bars 1 (RH) and 2 (LH) to respective rotor 3 (RH) and 4 (LH) with screws 5, spring washers 6, washers 7, screws 8 and nuts 9.

In this step, you will use:

Item 5 : 12 screws M12x30
 (0.47"x1.18")

Item 6 : 12 spring washers ϕ 13
 (ϕ 0.51")

Item 7 : 24 washers ϕ 13 (ϕ 0.51")

Item 8 : 12 screws M12x40
 (0.47"x1.57")

Item 9 : 12 nuts M12

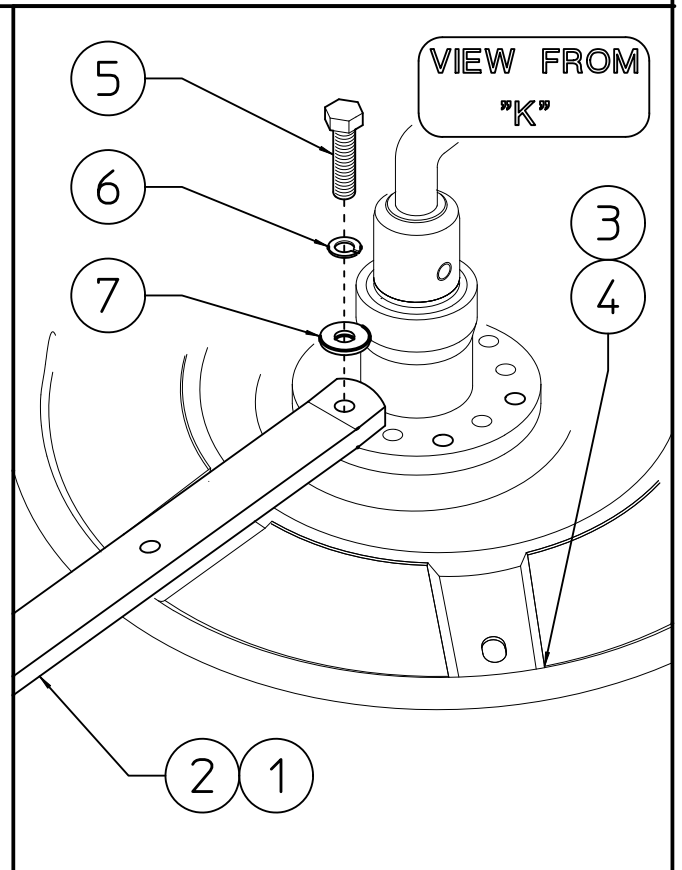

STEP "E"

Attach the lateral guard 1 and 2 (RH-LH) to machine body using screws 3 and washers 4. Attach grease nipples 5 in the proper holes.

In this step, you will use:

Item 3 : 4 screws M12x60 (0.47"x2,36")

Item 4 : 4 washers $\varnothing 13$ ($\varnothing 0.51$ ")

Item 5 : 2 grease nipples M10

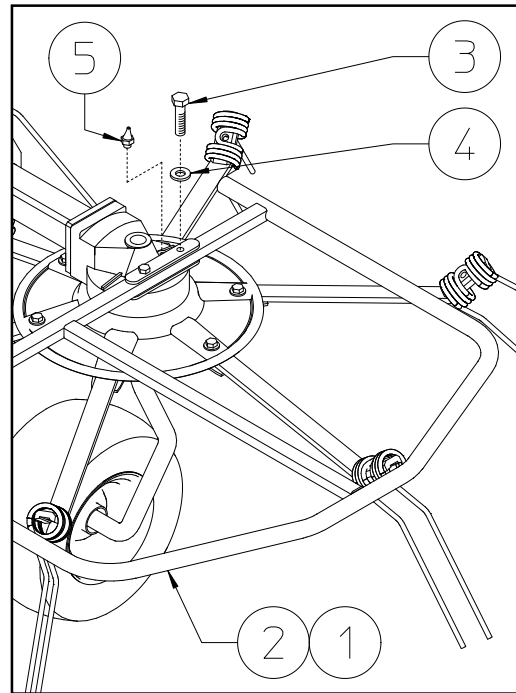

STEP "F"

Apply caps 3 to lateral guard 1-2 (RH-LH) .

In this step, you will use:

Item 3 : 4 caps $\varnothing 32$ ($\varnothing 1.25$ ")

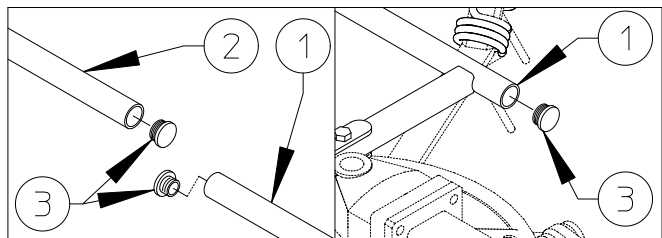

Assembly is now completed, and the machine should appear as shown in the illustration.

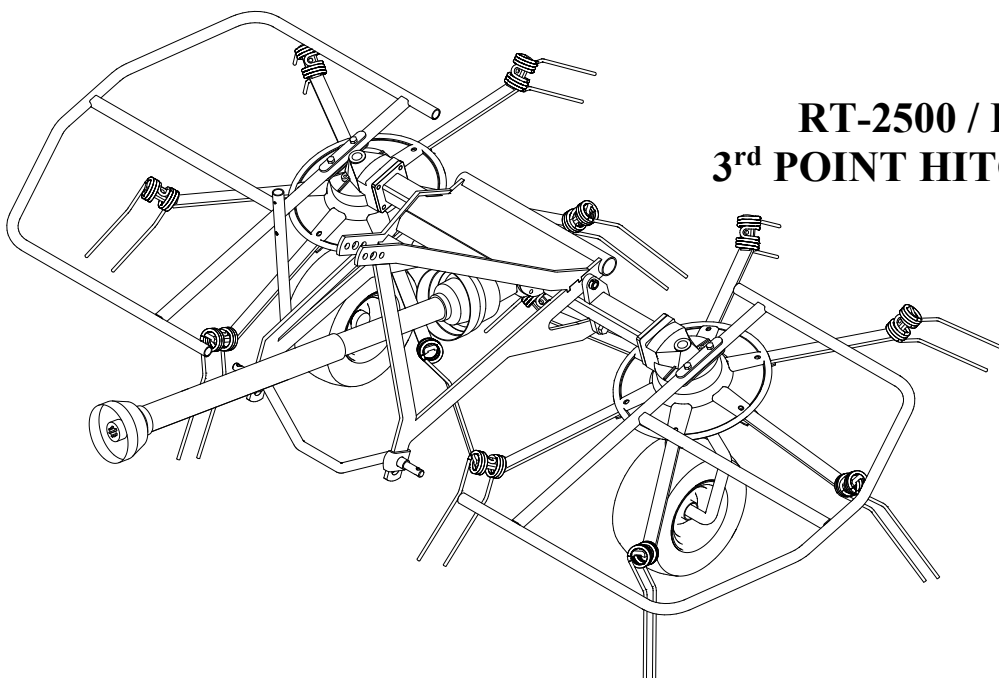

5) ADJUSTMENT, PREPARATION AND USE

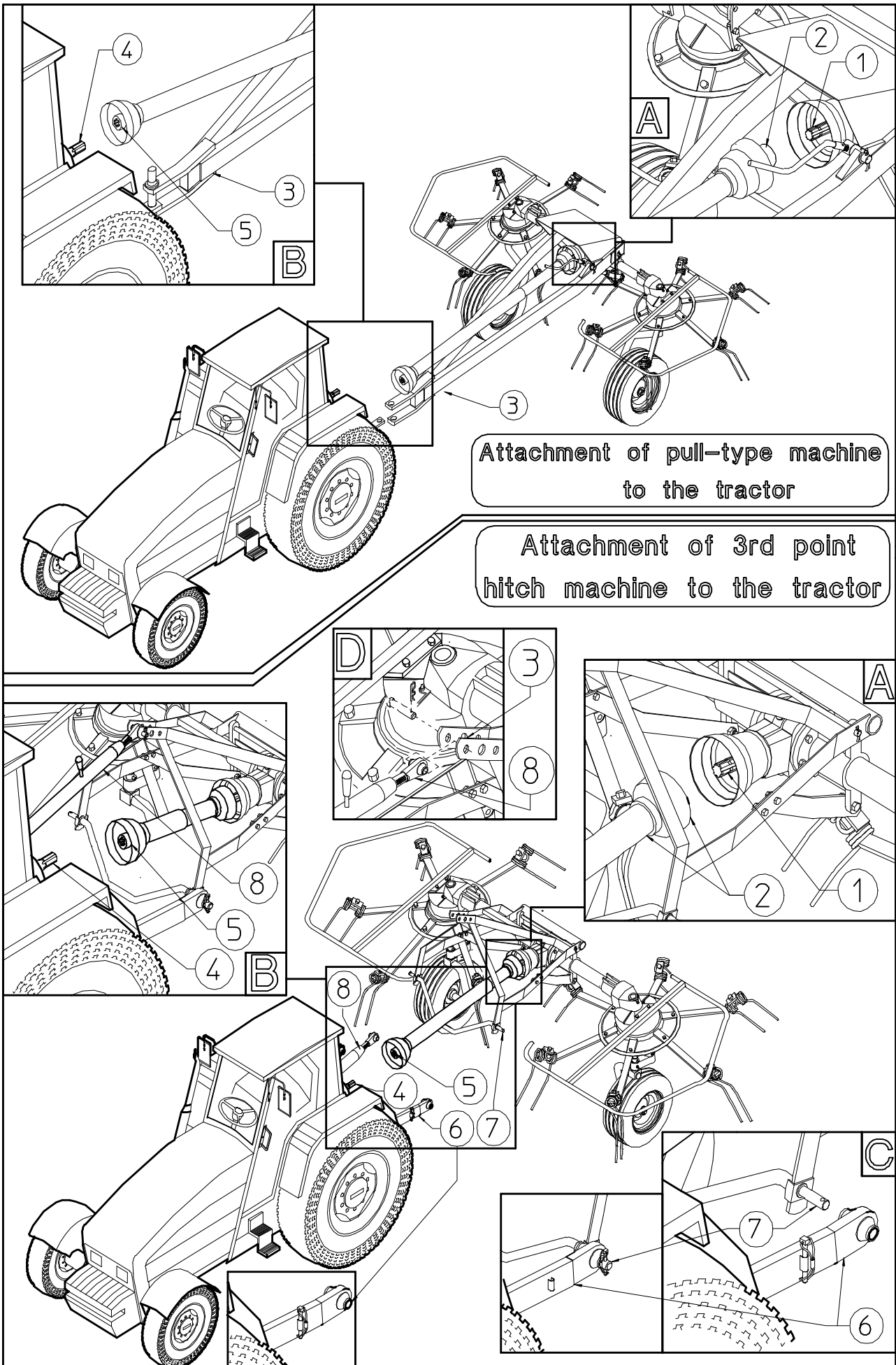

5) ADJUSTMENT, PREPARATION AND USE

INTRODUCTION

Connection to the tractor is highly dangerous. Take great care and carry out the entire operation in strict compliance with the following instructions. Nobody should go near the area between the tractor and the machine. Check that all warning and danger signs are in place and legible. Check that the tractor is in good running order. Refer to the tractor operator's manual.

ATTACHMENT OF PULL-TYPE MACHINE TO THE TRACTOR

The attachment of pull-type machine to the tractor is very simple, as it is only necessary to couple the drawbar 3 to the tractor hitch using a pin of appropriate size, strength and shape.

ATTACHMENT OF 3rd POINT HITCH TYPE MACHINE TO THE TRACTOR

Connect the lifting arms 6 to the pins 7 of the machine and fasten with appropriate split pins (see fig."C"). Connect the tie rod (or hydraulic cylinder) 8 with appropriate pin and split pin on the 3rd point hitch 3 (see fig.D-B).

CONNECTING CARDAN SHAFT INFORMATION

More detailed information may be found in the cardan shaft manual which, together with this manual, is an essential part of the accident-prevention documentation. It is your responsibility to read and comply with this documentation. If information given in this manual should conflict with that given in the cardan shaft manual, you should follow the instructions given by the cardan shaft manufacturer.

CONNECTING THE CARDAN SHAFT

Fit the inner cardan shaft 2 at the machine shaft 1 (see fig."A") Fit the outer cardan shaft 5 at the tractor shaft 4 (see fig."B"). Note: If a safety system is provided, this should be fitted to the machine shaft, not to tractor shaft.

NOTE: During both transport and use, avoid conditions where the cardan shaft is extended to the maximum. In all working conditions, the telescopic tube must overlap by at least 1/3 of their length (fig.1). Conversely, when the cardan shaft is contracted to the maximum, there should still be a gap of approximately 50mm-2" (fig.2).

Take particular care when connecting the two cardan shaft end forks and make sure that they are fully secured. This is achieved by inserting the safety pins and bolts 1 in the special slots 2 (fig.3) on the power takeoff shafts on both the tractor and machine ends. A loose shaft could come apart and cause considerable mechanical damage and serious injury to person.

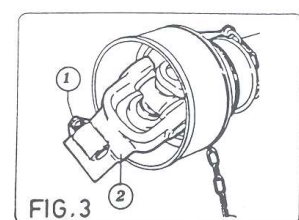
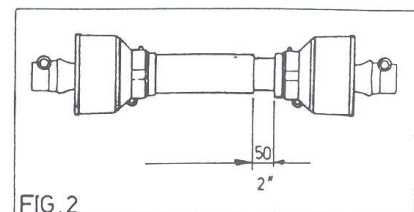
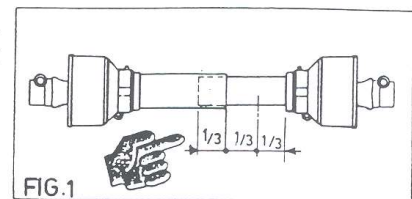

TRANSPORT INSTRUCTIONS FOR RT MANUAL FOLD

Regarding pull type machines, before beginning the transport, it is necessary to level the tine arms 2 using handle 1.

NOTE: The machine ready for transport should appear as shown in the illustration.

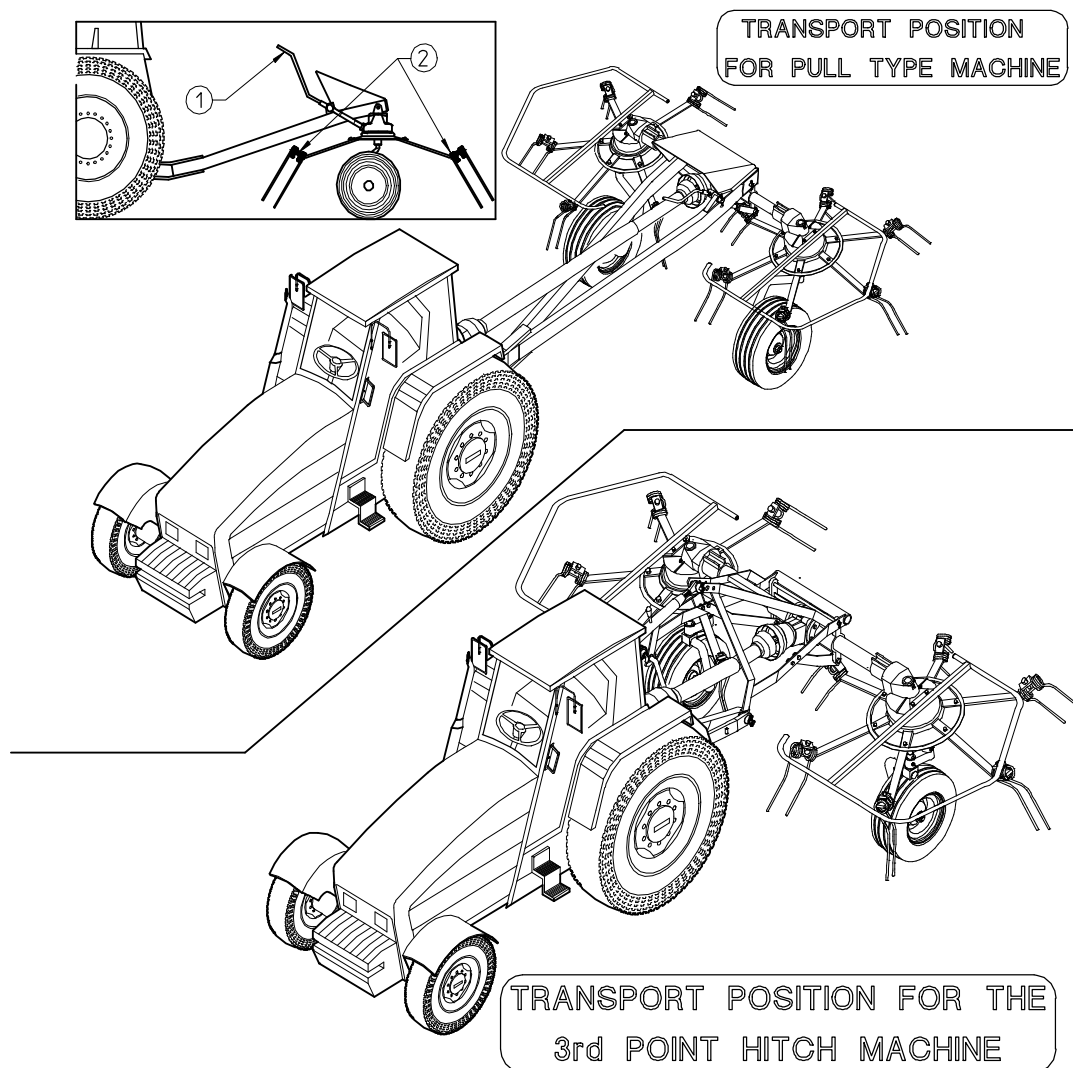

TRANSPORT BY ROAD

After the machine has been attached to the tractor as previously described and before transporting it to or from fields or any other workplace, the following instructions should be heeded:

Before setting off with the machine attached to the tractor, check the local road transport regulations. During transport keep the machine fully raised with the power takeoff disengaged and the lifting unit immobilised. Check that all guards, safety protection and locking split pins are in place, functioning and correctly fitted. Ensure that nobody leans against, or climbs on to, the machine during transport. The RT is an agricultural machine NOT designed for persons or goods. Consult the tractor maintenance and use manual where necessary. Maintain constant control over the vehicle and ensure that you know how to stop the tractor quickly and switch off the engine. When on a public road, observe all highway code regulations. Drive near the edge of the road and try not to obstruct traffic. Do not park the tractor and/or the machine where it might obstruct, or be a danger to, any public right of way. Avoid going onto a public road if the tractor or machine is very dirty you could leave a trail of soil, grass and other matter which could dirty the road and obstruct normal traffic.

USE IN THE FIELD (RT/5200 MANUAL FOLD)

Once the machine is prepared, before beginning work read the chapter on “General Instructions for Use in the Field” (see pg.26)

ADJUSTMENT FOR CORRECT WORKING POSITION (PULL TYPE MACHINE)

These machines are very easily adjusted. For best operation, the tines 1 on the front side of the machine should brush the ground. To obtain this, turn the adjustment crank 2.

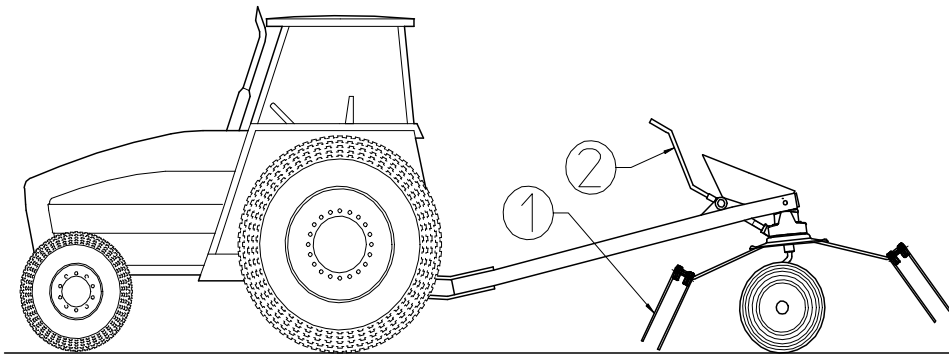

ADJUSTMENT FOR CORRECT WORKING POSITION (3rd POINT HITCH MACHINE)

These machines are very easily adjusted. For best operation, the tines 1 on the front side of the machine should brush the ground. To obtain this, turn the adjustment tie rod (or hydraulic cylinder) 2.

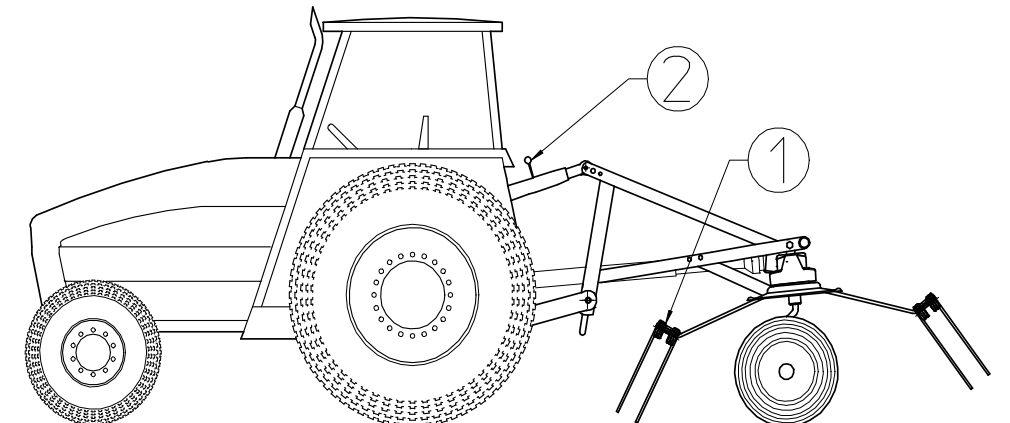

TEMPORARY PARKING

- 1) Choose a flat, hard open space away from frequented areas if possible.
- 2) Switch off the engine, leaving the tractor in gear.
- 3) Remove the ignition key.
- 4) Disconnect the cardan shaft at the tractor end.
- 5) Unhitch the tractor drawbar coupling pin.



GENERAL INSTRUCTIONS FOR FIELD USE

Before starting work, familiarise yourself with the following general instructions:



Before using the machine ensure that all safety precautions are taken.

Check that all safety protection and guards are in place and working.

Inspect the work site in order to familiarise yourself with the terrain.

Do not start the tractor before being properly seated in the driving position.

Do not start the machine if it is damaged (or even if you only suspect it is damaged) and inform your nearest dealer of the problem and ask for assistance.

Do not allow yourself to become distracted when working - give your full attention to the job in hand.

Maintain constant control over the tractor and ensure that you know how to stop quickly and switch off the engine.

Caution when working on inclines. It is better to work from the bottom to the top of an incline (or from the top to the bottom), rather than across an incline where there is a risk of overturning. Check and heed the instructions supplied by the tractor manufacturer, especially those concerning the maximum incline on which it is possible to work.

It is advisable to reduce speed when working and manoeuvring on inclines and only to change speed and direction gradually.

Do not make sudden stops or starts.

Do not work on wet or slippery grass or terrain, or anywhere where grip is poor. If this is unavoidable, work at a slow speed so as to ensure operator safety.

Always switch off the tractor engine, apply the parking brake and remove the ignition key whenever you have to attend to the machine to make adjustments or to remove grass and other objects which might be entangled in the machine.

Before leaving the tractor, disengage the power takeoff, lower the machine until its wheels are on the ground and put the hydraulic directional control lever into the locked position.

Never go near the rotors until they have completely stopped moving.

Never attempt to make adjustments to the machine while it is running. Always stop the machine before carrying out any such work. Do not oil the machine when it is running or is connected to the power takeoff.

Do not use the control levers as handholds since they can move and do not give a secure grip. Furthermore, any involuntary movement of a control lever can cause unintentional movement of the tractor or machine.

6) MAINTENANCE DIRECTIONS

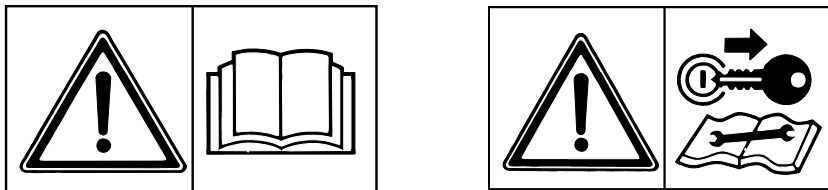

All cleaning, lubrication and maintenance operation must be carried out with the machine disconnected from the tractor.

In an emergency with the machine still connected to the tractor, switch off the engine, apply the parking brake, disengage the power takeoff and remove the ignition key from the instrument panel.

Regular, correct maintenance and proper operation are the basic prerequisites for the long-term efficiency and safe operation the machine.

Pay special attention to all instructions given on signs located on the machine.

All maintenance should be carried out in an area having the proper equipment readily available and in good condition.

This area must always be kept clean and dry and must have enough surrounding space to facilitate operations.

Any work must be carried out by trained personnel. Contact the dealer nearest to you. Respect the warnings and procedures for maintenance and technical assistance given in this manual.

Do not use petrol, solvents or other flammable liquids as detergents.

Use commercial non-flammable and non-toxic solvents, authorised by competent bodies.

Do not use compressed air or water at high pressure to clean the machine. If this is unavoidable, then wear goggles with side protection and limit the pressure as much as possible. When the work is finished, and with the machine disconnected from the tractor, inspect and check the machine completely.

6) MAINTENANCE POINTS

ITEM	Q.ty	DESCRIPTION	OPERATION	EVERY HOURS	NOTES
1	1	GEARBOX	LUBRICATE	100	SEE NOTE A
2	2	WHEEL SUPPORTS	LUBRICATE	8	(3 rd point hitch)
3	2	LATERAL ROTORS	LUBRICATE	50	*
4	2	ARM LINKAGE PINS	CLEAN	SEE NOTE C	With brushes, etc. (3 rd point hitch)
5	1	PTO	CLEAN/ LUBRICATE	SEE NOTE B	WITH BRUSHES, etc
6	1	STRUT PIN	LUBRICATE	8	(pull type)
7	1	ADJUSTMENT FORK	LUBRICATE	8	(pull type)
8	1	STRUT BUSHING	LUBRICATE	8	(pull type)
9	2	WHEELS	CHECK PRESSURE	SEE NOTE C	INFLATE TO 35 PSI
10	1	CARDAN SHAFT	SEE CARDAN	SHAFT	MAINTENANCE
11	*	General checking of bolts, security pins and split pins to be carried out initially after the first 8 hours of use. Subsequently every 50 hours and whenever the machine is laid up for extended periods.			
GREASE TYPE : NGLI 2 EP					

NOTE A:

COMPLETE LUBRICATION OF THE CENTRAL GEARBOX 1:

The complete lubrication of gearbox 1 is done the first time at the manufacturer's plant, after which it must be topped up periodically, as according to the lubrication points table. A complete change or fill is necessary only for the replacement and /or repairing of the entire gearbox or internal parts. In this case, it is necessary to: remove caps H-K and inject the grease, using grease pump W, into hole T until the grease comes out of hole K. Then screw caps H-K back into place on central gearbox 1.

Periodic checking and topping up of central gearbox 1:

Every 100 hours of working time, check and top up central gearbox 1. It is a good practice, however, to check the condition and quantity of grease after all long periods of inactivity, especially when starting to work again after the winter break. To top up the grease in central gearbox 1 it is necessary to: remove caps H-K and inject the proper amount grease into hole J, using grease pump W. Then screw caps H back into place on housing 1.

NOTE B:

Each time the Cardan shaft is disconnected and Whenever the machine is stopped, we recommended that you clean the power takeoff shaft and replace the protective cover (use additives of a type permitted by anti-pollution regulations).

NOTE C: Each time the machine is connected to the tractor.

CARDAN SHAFT MAINTENANCE



More detailed information may be found in the Cardan shaft manual which, together with this manual, forms an essential part of the accident-prevention documentation. It is your responsibility to read and comply with this documentation. If information given in this manual conflicts with that given in the Cardan shaft manual, you should follow the instructions given by the Cardan shaft manufacturer.

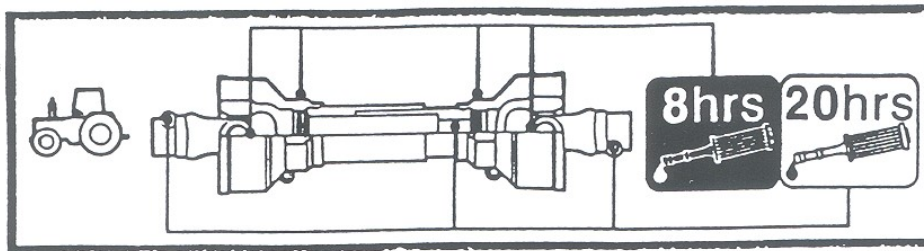

MAINTENANCE OF SLIDING PARTS

DISMANTLING

1) Turn the two eccentric pins on the ferrule until the protective cone comes free.

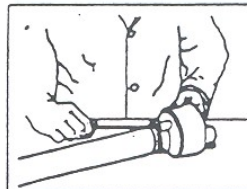

2) Withdraw the shaft protective guard.

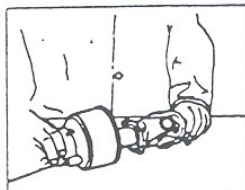

3) Check the condition of the ferrule and all protective parts.

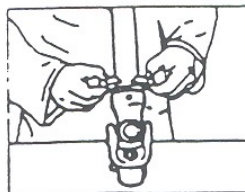

ASSEMBLY

4) Lubricate supporting ferrule seating.

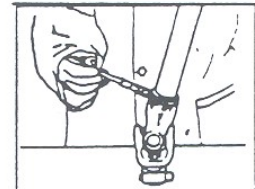

5) Refit the supporting ferrule.

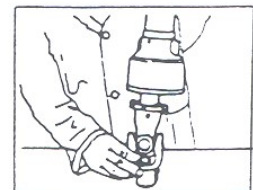

6) Reattach the protective guard to the cardan shaft by turning the eccentric pins on the supporting ferrule.

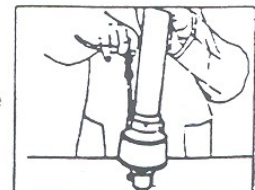

GENERAL INSTRUCTIONS FOR REPAIR WORK

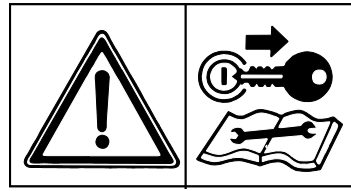
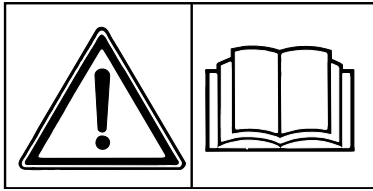

Any repair work must be carried out with the machine at rest and disconnected from the tractor.

Do not carry out welding without authorisation and instructions from the manufacturers.

Disconnect the machine from the tractor before any welding work in order not to damage the battery. Always use a protective mask, goggles and gloves when welding, sanding or grinding or when using a hammer or drill.

Always work on the machine out of doors. If you have to operate the machine when connected to the tractor in an enclosed area (for example when testing after repair and/or maintenance) ensure that there is sufficient ventilation so as to prevent noxious exhaust gases accumulating.

In order to acquire the necessary control and to operate in safety, practise various manoeuvres by simulating those required in the workplace with the help of an experienced person.

If you activate the machine while it is raised from the ground, make sure there is nobody standing nearby or in a dangerous position.

LAYNING UP FOR EXTENDED PERIODS

At the end of the season, or when an extended period of inactivity is envisaged, it is advisable to:

Clean the machine following instructions and allow it to dry.

Check it carefully and replace any damaged or worn parts.

Thoroughly tighten all screws and bolts.

Grease the machine thoroughly and then cover it completely and lay it up in a dry place.

It is to the user's advantage to carry out these operations carefully. In this way, he will have a machine in perfect condition when work is restarted.

On recommencing work, repeat all the proper checks so as to be certain of working in conditions of maximum safety.

NOISE AND VIBRATION

Noise affecting the tractor driver (from the machine only) is less than 80dB.

Vibration from the machine affecting the upper body and limbs of the driver is insignificant and is lower than the values given in Point 3.6.3 of Enclosure 1 of the Machine Directives (89/392/EEC, 91/386/EEC)

THE FOLLOWING SHOULD BE NOTED IF THE MACHINE IS SCRAPPED

The machine consists mainly of ferrous material, which must be disposed of according to the regulations in force in the country concerned.

There is also a small amount of plastic, which must be disposed of according to the regulations in force in the country concerned.

There is very small amount of residual grease, which must be disposed of according to the regulations in force in the country concerned.

SPARE PARTS LIST

FOR CORRECT SPARE PARTS ORDER IT IS NECESSARY TO SPECIFY:
TABLE NUMBER, ITEM, PART NO, DESCRIPTION AND QUANTITY OF
PARTS REQUIRED.

ITEMS DESCRIBED AS RH AND LH ARE MEANT FACING REAR OF
MACHINE.

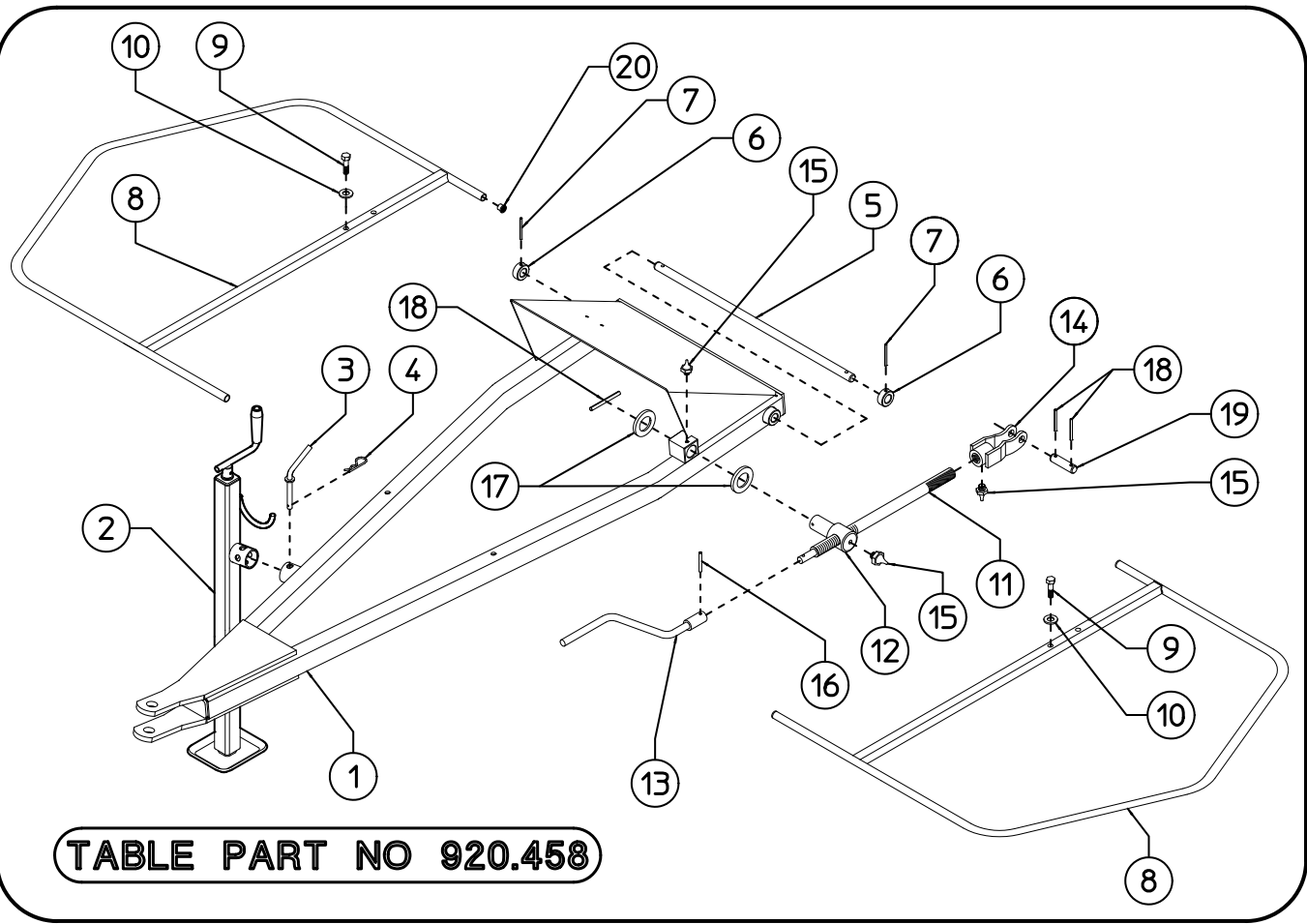
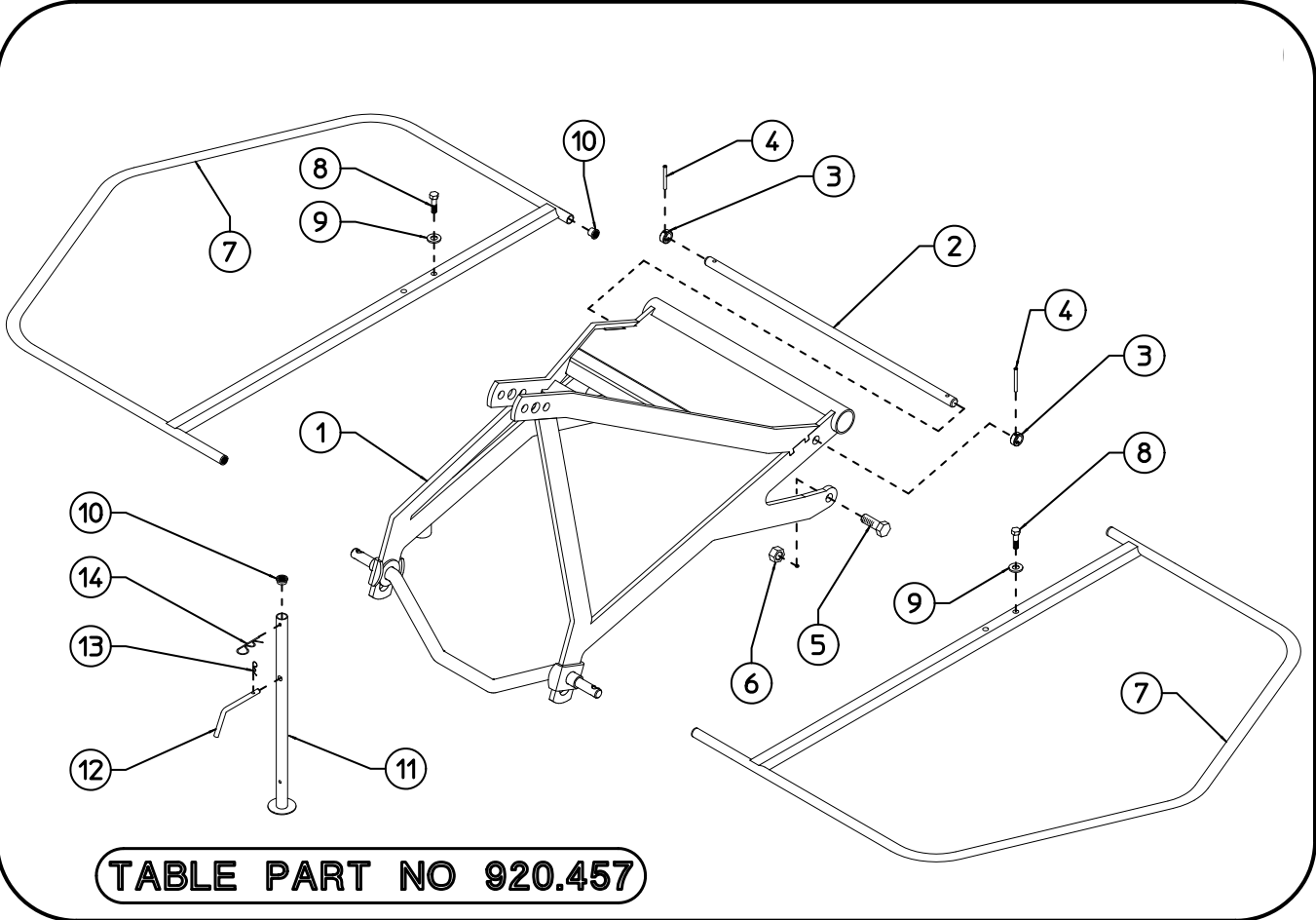

RT/2500-RT/3000 - TABLE PART NO 920.457 - 3rd POINT HITCH				
ITEM	Q.ty	PART NO	DESCRIPTION	NOTE
1	1	260.154	3rd POINT HITCH	
2	1	250.927	PIN	
3	2	250.928	BUSH \varnothing 20,5-30x12	
4	2	600.182	SPRING PIN \varnothing 5x30 DIN 1481	
5	2	631.343	SCREW M20x55 DIN 933	
6	2	600.717	NUT M20 DIN 980 KL8	
7	2	260.155	LATERAL GUARD (RH-LH)	
8	4	600.618	SCREW M12x60 DIN 931 8.8	
9	4	600.634	SPRING WASHER \varnothing 13	
10	5	200.309	PLUG	
11	1	220.438	STAND	
12	1	200.328	PIN	
13	1	600.019	PIN	
14	1	600.020	PIN	

RT/2500-RT/3000 - TABLE PART NO 920.458 - PULL TYPE				
ITEM	Q.ty	PART NO	DESCRIPTION	NOTE
1	1	260.209	DRAWBAR	
2	1	250.849	STAND	
3	1	200.959	PIN	
4	1	600.019	PIN	
5	1	250.927	PIN	
6	2	250.928	BUSH \varnothing 20,5-30x12	
7	2	600.182	SPRING PIN \varnothing 5x30 DIN 1481	
8	2	260.036	LATERAL GUARD (RH-LH)	
9	4	600.618	SCREW M12x60 DIN 931 8.8	
10	4	600.634	SPRING WASHER \varnothing 13	
11	1	200.766	TIE ROD M27	
12	1	220.807	PIN	
13	1	200.438	HANDLE	
14	1	220.808	FORK	
15	3	600.124	GREASE NIPPLE M6	
16	1	600.773	SPRING PIN \varnothing 6x30 DIN 1481	
17	2	200.273	SHIM \varnothing 30,3-39,8x1	
18	3	600.673	SPRING PIN \varnothing 5x40 DIN 1481	
19	1	220.809	PIN	
20	4	200.309	PLUG	

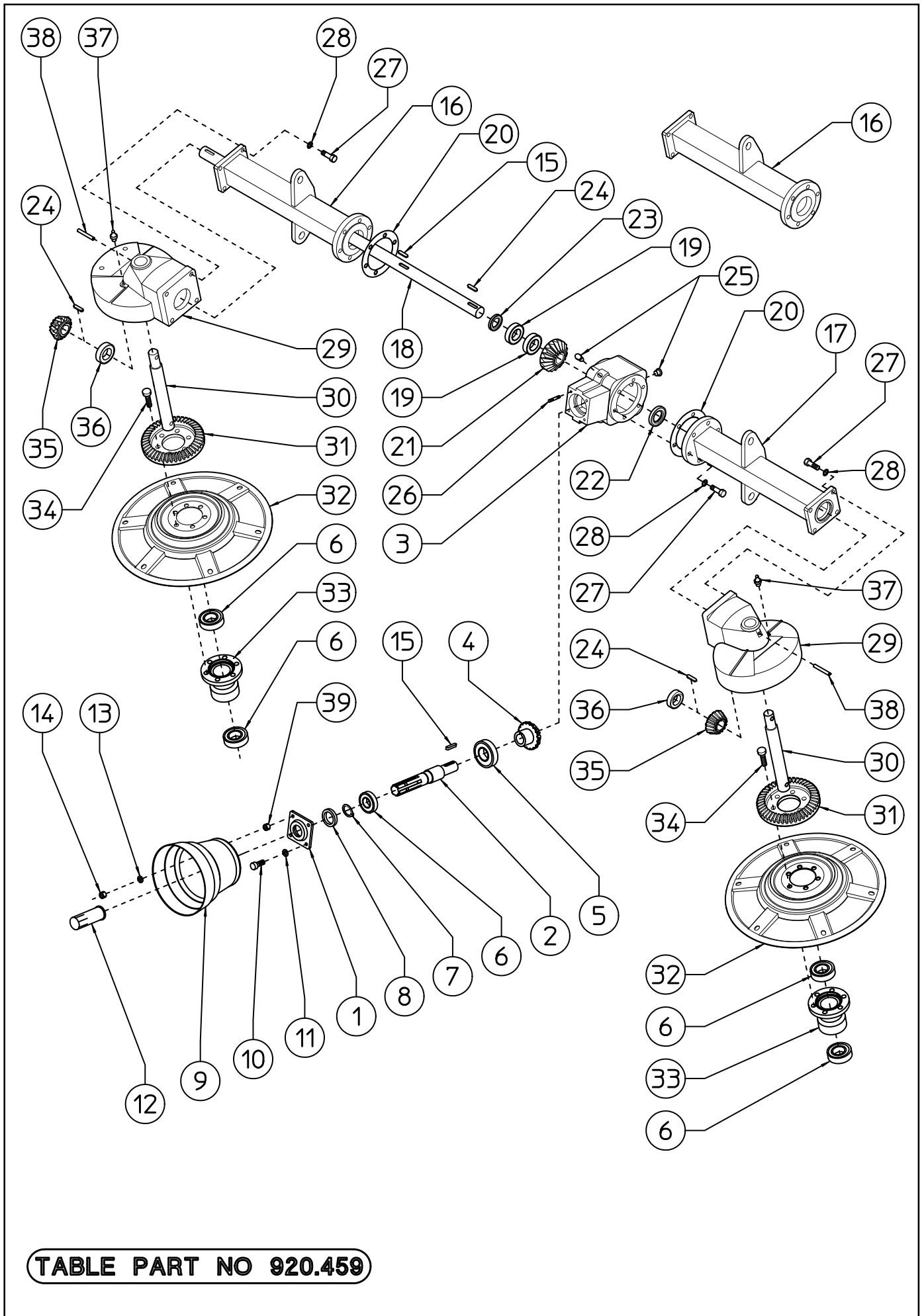
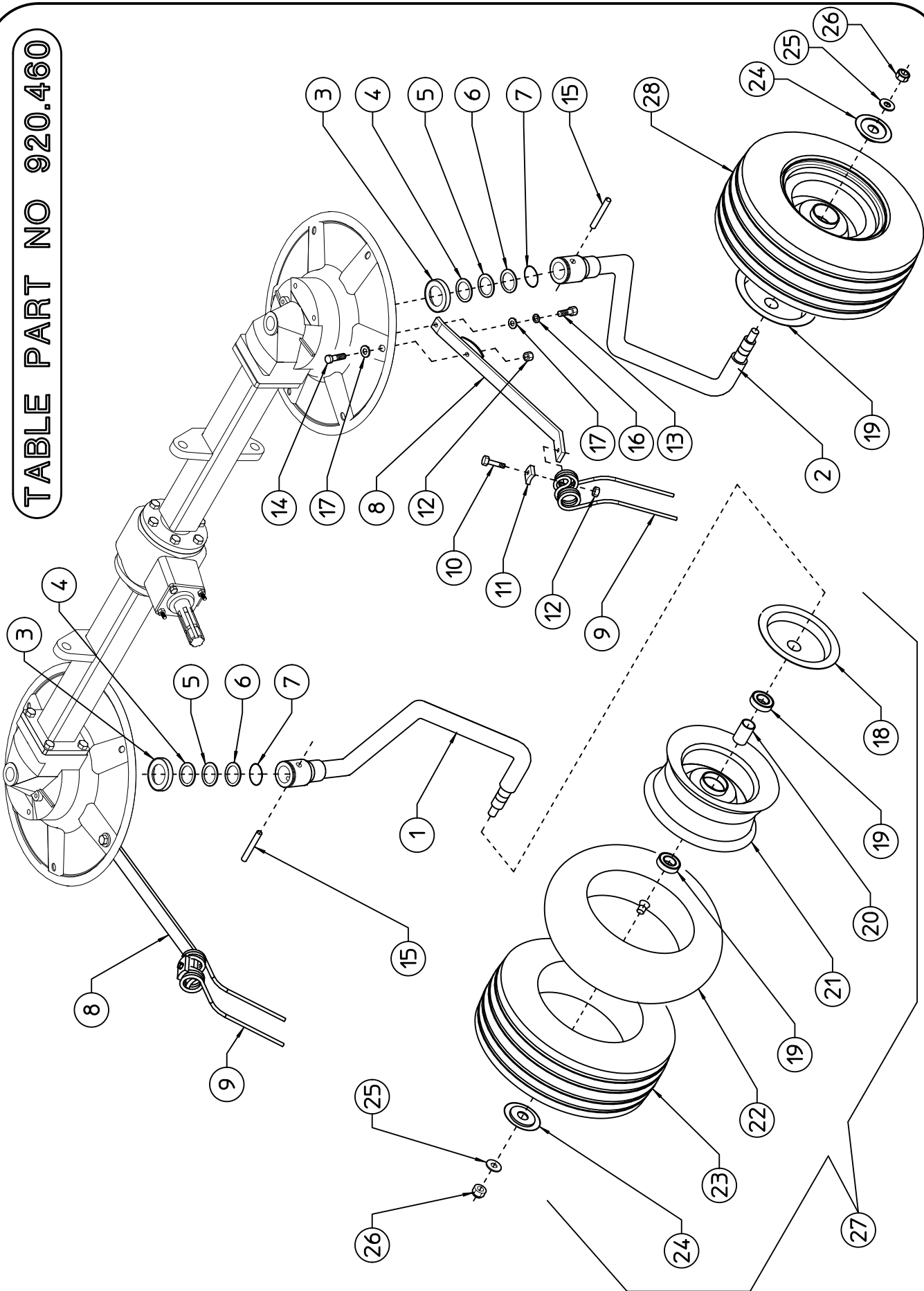

TABLE PART NO 920.459

TABLE PART NO 920.459				
ITEM	PART NO	Q.ty	DESCRIPTION	NOTE
1	200.395	1	GEARBOX CAP	
2	200.396	1	SHAFT	
3	230.225	1	GEARBOX	
4	200.397	1	PINION Z16	
5	600.827	1	BEARING 6209 2RS	
6	600.608	5	BEARING 6207 2RS	
7	600.333	1	SNAP RING E35 DIN471	
8	600.555	1	OIL RETAINER \varnothing 35/52x10	
9	600.681	1	HOOD	
10	600.223	2	SCREW M8x20 DIN 933 8.8	
11	600.229	2	SPRING WASHER \varnothing 8,4 similar to DIN 127B	
12	600.172	1	SHAFT GUARD	
13	600.115	2	WASHER \varnothing 8,4 DIN 125A	
14	600.037	2	NUT M8 DIN 934	
15	600.556	2	FLAT KEY B8x7x40 DIN 6885	
16	260.156	1	RH CENTER AXLE	ONLY 3rd POINT
16	220.791	1	RH CENTER AXLE	ONLY PULL TYPE
17	220.792	1	LH CENTER AXLE	
18	220.788	1	DRIVE SHAFT	
19	600.579	2	BEARING 6206	
20	200.405	2	GASKET	
21	200.400	1	CROWN Z23	
22	600.561	1	OIL RETAINER \varnothing 30/62x10	
23	600.582	1	OIL RETAINER \varnothing 30/56x10	
24	600.559	3	FLAT KEY B8x7x30 DIN 6885	
25	600.580	2	PLUG 3/8"	
26	600.558	2	BOLT M8x30 UNI 5911 8.8	
27	620.301	20	SCREW M12x35 DIN 933 10.9	
28	600.018	20	SPRING WASHER \varnothing 13 similar to DIN 127B	
29	220.637	2	GEARBOX	
30	200.407	2	PIN	
31	220.833	2	CROWN Z35	
32	220.834	2	TINE DISC	
33	220.836	2	HUB	
34	620.788	12	SCREW M12x30 DIN 933 10.9	
35	200.420	2	PINION Z15	
36	600.609	2	BEARING 6206 2RS	
37	600.247	2	GREASE NIPPLES M10	
38	640.064	2	SPRING PIN \varnothing 10x55 DIN 7334	
39	600.553	2	NUT M8 UNI 5587	

TABLE PART NO 920.460



RT/2500-RT/3000 - TABLE 920.460 - PULL TYPE VERSION					
ITEM	Q.ty	PART NO	PART NO	DESCRIPTION	NOTE
		RT/2500	RT/3000		
1	1	210.590	210.590	RH LATERAL SUPPORT	
2	1	210.591	210.591	LH LATERAL SUPPORT	
3	2	220.821	220.970	SPACER	
4	2	200.419	200.419	SHIM (ø35,2/51,8x1)	*Q.ty as required
5	2	200.274	200.274	SHIM (ø35,2/48x0,5)	*Q.ty as required
6	2	200.490	200.490	SHIM (ø35,2/51,8x0,3)	*Q.ty as required
7	2	600.568	600.568	GASKET (OR 47,63x3,53)	
8	12	250.402	230.926	ARM	
9	12	210.574	210.574	TINE	
10	12	620.508	620.508	SCREW (M12x45-5737 ZN 10.9)	
11	12	200.402	200.402	PLATE	
12	24	600.077	600.077	NUT (M12-DIN 980)	
13	12	620.788	620.788	SCREW (M12x30-5739 ZN 10.9)	
14	12	640.218	640.218	SCREW (M12x40-5739 ZN 10.9)	
15	2	640.054	640.054	SPRING PIN (ø10x55-DIN 7334)	
16	12	600.018	600.018	SPRING WASHER (ø13 ZN)	
17	24	220.864	220.864	WASHER (ø12,3/28,5x3)	
18	2	210.596	210.596	DUST COVER, INNER	
19	4	600.602	600.602	BEARING (6205 2RS)	
20	2	200.415	200.415	SPACER	
21	2	610.273	610.273	RIM	
22	2	610.274	610.274	TUBE	
23	2	610.275	610.275	TIRE	
24	2	200.416	200.416	DUST COVER, OUTER	
25	2	600.031	600.031	WASHER (ø17 ZN)	
26	2	600.080	600.080	NUT (M16-DIN 980)	
27	2	610.272	610.272	TIRE ASSY (16x6,50-8 6PLY)	

TABLE PART NO 920.461

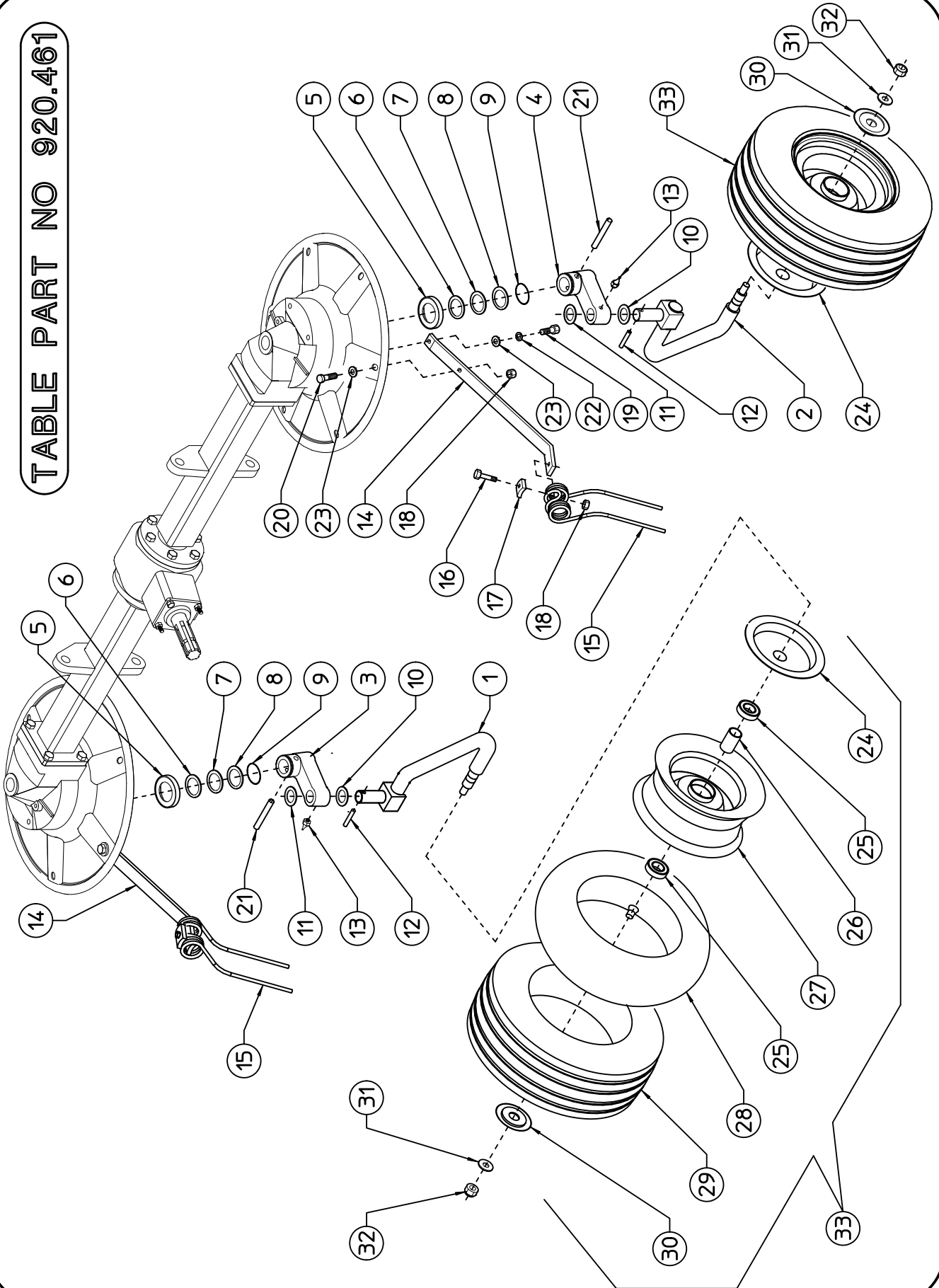

RT/2500-RT/3000 - TABLE 920.461 - 3rd POINT HITCH

ITEM	Q.ty	PART NO		DESCRIPTION	NOTE
		RT/2500	RT/3000		
1	1	230.231	230.231	RH SUPPORT	
2	1	230.232	230.232	LH SUPPORT	
3	1	200.467	200.467	RH SUPPORT	
4	1	200.468	200.468	LH SUPPORT	
5	2	220.821	220.970	SPACER	
6	2	200.419	200.419	SHIM (ø35,2/51,8x1)	*Q.ty as required
7	2	200.274	200.274	SHIM (ø35,2/48x0,5)	*Q.ty as required
8	2	200.490	200.490	SHIM (ø35,2/51,8x0,3)	*Q.ty as required
9	2	600.568	600.568	GASKET (OR 47,63x3,53)	
10	2	200.273	200.273	SHIM (ø30,3/39,8x1)	*Q.ty as required
11	2	200.272	200.272	SHIM (ø30,3/39,8x0,5)	*Q.ty as required
12	2	600.539	600.539	SPRING PIN (ø6x45-6873)	
13	2	600.124	600.124	GREASE NIPPLE (M6)	
14	12	250.402	230.926	ARM	
15	12	210.574	210.574	TINE	
16	12	620.508	620.508	SCREW (M12x45-5737 ZN 10.9)	
17	12	200.402	200.402	PLATE	
18	24	600.077	600.077	NUT (M12-DIN 980)	
19	12	620.788	620.788	SCREW (M12x30-5739 ZN 10.9)	
20	12	640.218	640.218	SCREW (M12x40-5739 ZN 10.9)	
21	2	640.064	640.064	SPRING PIN (ø10x55-DIN 7334)	
22	12	600.018	600.018	SPRING WASHER (ø13 ZN)	
23	24	220.864	220.864	WASHER (ø12,3/28,5x3)	
24	2	210.596	210.596	DUST COVER, INNER	
25	4	600.602	600.602	BEARING (6205 2RS)	
26	2	200.415	200.415	SPACER	
27	2	610.273	610.273	RIM	
28	2	610.274	610.274	TUBE	
29	2	610.275	610.275	TIRE	
30	2	200.416	200.416	DUST COVER, OUTER	
31	2	600.031	600.031	WASHER (ø17 ZN)	
32	2	600.080	600.080	NUT (M16-DIN 980)	
33	2	610.272	610.272	TIRE ASSY (16x6,50-8 6PLY)	

CARDAN SHAFT B2 130 E + LW2
 PART NO. 600.680
 RT/2500-RT/3000

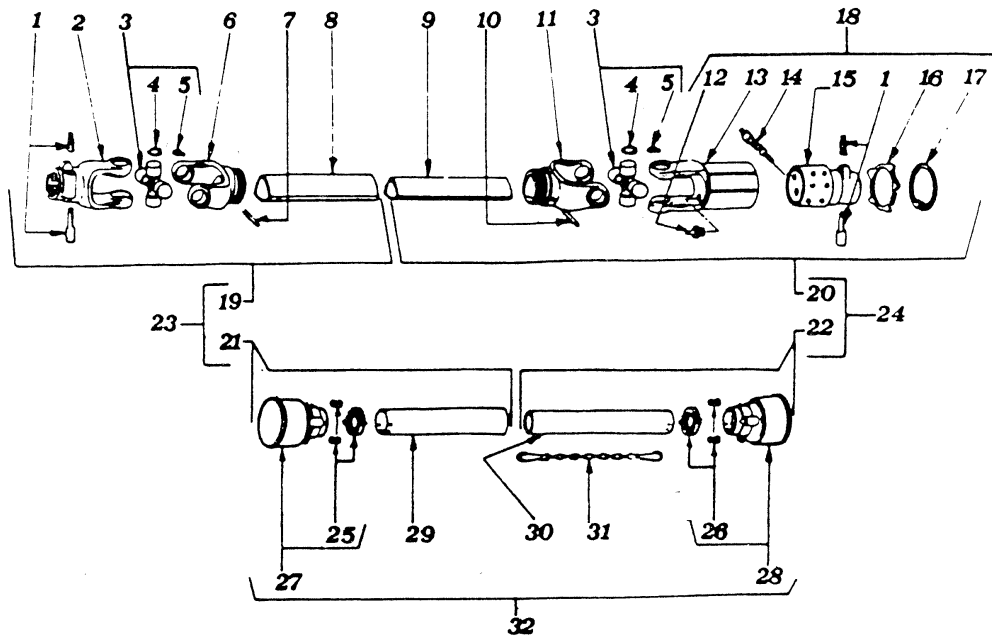

CARDAN SHAFT 600.680				
ITEM	PART NO	Q.ty	DESCRIPTION	NOTE
1	610.057	2	COMPLETE PUSH BUTTON	
2	610.051	1	YOKE	
3	610.052	2	CROSS JOURNAL ASS.	
4	610.248	8	CIRCLIP	
5	610.206	2	GREASE NIPPLE	
6	610.249	1	OUTER TUBE YOKE	
7	610.211	1	FLEXIBLE PIN	
8	610.210	1	CM. CARDAN TUBE	
9	610.123	1	CM. CARDAN TUBE	
10	600.027	1	FLEXIBLE PIN	
11	610.250	1	INNER TUBE YOKE	
12	610.216	1	GREASE NIPPLE	
13	610.251	1	OUTER CASING WITH YOKE	
14	610.218	16	RATCHET TOOTH	
15	610.252	1	HUB	
16	610.220	1	REATING WASHER	
17	610.253	1	CIRCLIP	
18	610.146	1	TORQUE LW2	
19	610.254	1	HALF SHAFT (WITHOUT GUARD)	
20	610.255	1	HALF SHAFT (WITHOUT GUARD)	
21	610.256	1	HALF SAFETY GUARD	
22	610.257	1	HALF SAFETY GUARD	
23	610.258	1	HALF SHAFT (WITH GUARD)	
24	610.259	1	HALF SHAFT (WITH GUARD)	
25	610.060	1	O. BEARING	
26	610.061	1	I. BEARING	
27	610.062	1	O. BASIC CONE	
28	610.063	1	I. BASIC CONE	
29	610.260	1	CM. SAFETY TUBE	
30	610.261	1	CM. SAFETY TUBE	
31	610.068	1	CHAINE	
32	610.262	1	SAFETY GUARD	
*	600.680	1	CARDAN SHAFT B2 130E + LW2	

CARDAN SHAFT B2 090 + LW2
 PART NO. 600.732
 RT/2500-RT/3000

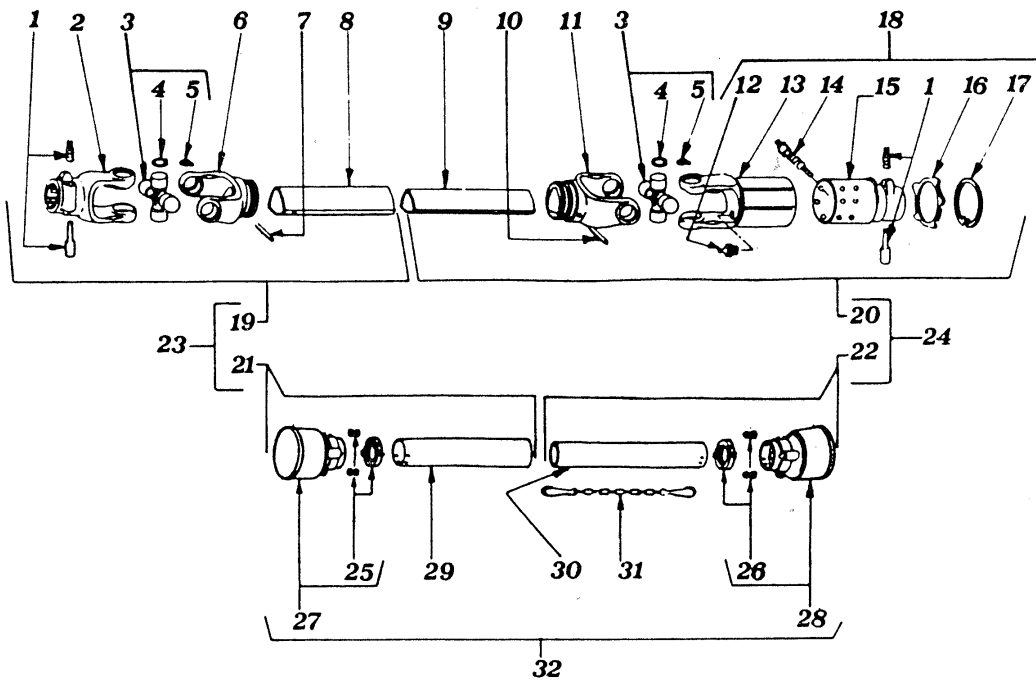

CARDAN SHAFT 600.732				
ITEM	PART NO	Q.ty	DESCRIPTION	NOTE
1	610.057	2	COMPLETE PUSH BUTTON	
2	610.051	1	YOKE	
3	610.052	2	CROSS JOURNAL ASS.	
4	610.248	8	CIRCLIP	
5	610.206	2	GREASE NIPPLE	
6	610.249	1	OUTER TUBE YOKE	
7	610.211	1	FLEXIBLE PIN	
8	610.210	1	CM. CARDAN TUBE	
9	610.123	1	CM. CARDAN TUBE	
10	600.027	1	FLEXIBLE PIN	
11	610.250	1	INNER TUBE YOKE	
12	610.216	1	GREASE NIPPLE	
13	610.251	1	OUTER CASING WITH YOKE	
14	610.218	16	RATCHET TOOTH	
15	610.252	1	HUB	
16	610.220	1	REATING WASHER	
17	610.253	1	CIRCLIP	
18	610.146	1	TORQUE LW2	
19	610.404	1	HALF SHAFT (WITHOUT GUARD)	
20	610.430	1	HALF SHAFT (WITHOUT GUARD)	
21	610.428	1	HALF SAFETY GUARD	
22	610.429	1	HALF SAFETY GUARD	
23	610.431	1	HALF SHAFT (WITH GUARD)	
24	610.432	1	HALF SHAFT (WITH GUARD)	
25	610.060	1	O. BEARING	
26	610.061	1	I. BEARING	
27	610.062	1	O. BASIC CONE	
28	610.063	1	I. BASIC CONE	
29	610.402	1	CM. SAFETY TUBE	
30	610.403	1	CM. SAFETY TUBE	
31	610.068	1	CHAINE	
32	610.069	1	SAFETY GUARD	
*	600.732	1	CARDAN SHAFT B2 090 E + LW2	

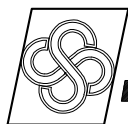

AGRICULTURAL MACHINERY
sitrex® s.r.l.

Zona Industriale-Viale Grecia, 8
06018 TRESTINA-(Perugia)-ITALY
Tel. +39.075.8540021-Telefax +39.075.8540523
e-mail: sitrex@sitrex.it www.sitrex.com

