



BAUMALIGHT™

STUMP BLASTER 3P24, 3P34 and 3P40

OPERATOR'S MANUAL

TABLE OF CONTENTS

1. INTRODUCTION	1
1.1 Overview	1
1.2 Intended Use And Foreseeable Misuse	1
2. SAFETY	2
2.1 Safety Alert Symbol And Safety Words	2
2.2 Operational Hazards.....	2
Prepare for Emergencies	3
Replace Safety Signs	3
Do Not Allow Riders	3
Lower Operating Speed	3
Avoid Rollover	3
Avoid Powerlines & Underground Utilities	4
Detach Stump Grinder Safely	4
Hazards from Modifying Equipment	4
Avoid Wood Dust Inhalation	5
2.3 Maintenance Hazards	6
3. SAFETY SIGNS	8
4. ASSEMBLY	10
4.1 Remove Stump Grinder From Pallet.....	10
4.2 Attach Driveline	11
4.3 Driveline Dimension	12
5. OPERATION	13
5.1 Preparation For Use	13
5.2 Pre-Operation Check List	14
5.3 Machine Components	14
5.4 Attaching Stump Grinder To Tractor.....	15
5.5 Detaching Stump Grinder From Tractor	17
5.6 Transporting.....	18
5.7 Adjusting Swing Speed.....	18
5.8 Carbide Teeth Break-In.....	19
5.9 First Time User Tips	19
5.10 Field Operation	20
6. SERVICE AND MAINTENANCE.....	22
6.1 Service.....	22
6.1.1 Replace Cutting Teeth.....	22
6.1.2 Replace Hydraulic Hoses.....	23
6.1.3 Adjust Slip Clutch.....	24
6.2 Maintenance.....	25
6.2.1 Every 6 Hours	25
6.2.2 Every 10 Hours	25
6.2.3 Every 200 Hours	26
7. TROUBLESHOOTING	27
8. STORAGE.....	28
8.1 Storing Grinder	28
8.2 Removing Grinder From Storage.....	28
9. WARRANTY.....	29

1. INTRODUCTION

1.1 Overview

Congratulations on your choice of a Baumalight 3-Point Stump Grinder to complement your stump grinding operation. This equipment has been designed and manufactured to meet the needs of a discriminating buyer for efficient grinding of stumps.

Model 3P24 has 34 teeth on a 24 in. cutter and models 3P34 and 3P40 have 54 teeth on a 34 in. cutter. This means less cutting for each tooth resulting in longer tooth life and smoother cutting for less wear on the tractor. Heavy tooth population makes finer mulch and smoother operation.

The cutting wheel is powered by the PTO (540) on your tractor with the swing and lift cylinders activated by the standard remote hydraulic connectors on the tractor.

Grease zerks and replaceable brass bushings are provided at major pivot points for extended service life.

The debris shields is standard equipment on all stump grinders. It is recommended that the stump grinder never be operated without one.

Safe, efficient and trouble free operation of your Stump Grinder requires that you and anyone else who will be operating or maintaining the Stump Grinder, read and understand the Safety, Operation, Maintenance and Troubleshooting information contained within the Operator's Manual.

This manual covers the Baumalight 3-Point Stump Grinder, models 3P24, 3P34 and 3P40. Use the Table of Contents as a guide to locate required information.

Keep this manual handy for frequent reference and to pass on to new operators or owners. Call your Baumalight dealer, distributor or the factory if you need assistance, information or additional copies of the manuals.

When this machine is worn out and no longer in use, it should be returned to the retailer or other party for recycling.

OPERATOR ORIENTATION - The directions left, right, front and rear, as mentioned throughout this manual, are as seen from the tractor driver's seat and facing in the direction of travel.

1.2 Intended Use And Foreseeable Misuse

The stump grinding tool is designed to be used by experienced operators, trained in the safe operation of a tractor and trained in the hazards related to using the stump grinder and the safe use of the grinder for the intended purpose. Operators will require personal protective equipment to reduce the risk from some hazards that cannot be completely eliminated or controlled by the design of the tool.

Each model in the family is intended to be used within the stump size limits shown in the catalog and in the implement specifications in the manual.

Care is required to ensure that the stump grinding tool will not come across metallic objects, stones or other materials harder than a typical stump while grinding.

The Stumpblaster stump grinding tools are not designed for use in hazardous atmospheres where there is a risk of fire or explosion due to flammable gases or vapors. Use in hazardous, explosive atmospheres is prohibited.

Serious injury or death of the operator or bystanders may be caused if the tool is misused. Misuse may also cause damage to the tractor carrying the implement.

2. SAFETY

2.1 Safety Alert Symbol And Safety Words

You must read, understand and follow the instructions given by the operating unit manufacturers, as well as the instructions in this manual.

The safety information in this manual is denoted by the safety alert symbol:



This symbol means ATTENTION! BECOME ALERT! YOUR SAFETY IS INVOLVED!

The level of risk is indicated by the following signal words:

DANGER

DANGER - Indicates a hazardous situation, which, if not avoided, **WILL** result in death or serious injury.

WARNING

WARNING - Indicates a hazardous situation, which, if not avoided, could result in death or serious injury.

CAUTION

CAUTION - Indicates a hazardous situation, which, if not avoided, could result in minor or moderate injury.

NOTICE

NOTICE - Indicates a situation that could result in damage to the equipment or other property.

2.2 Operational Hazards

WARNING

Prevent serious injury or death.

Read and understand this manual before operating stump grinder.

Always stop engine and remove key before leaving operators seat.

Never allow anyone near the stump grinder during operation.

Travel at a safe speed.

WARNING

Prevent serious injury or death from moving parts.

Moving parts can crush and dismember.

Do not operate without guards and shields in place.

Disconnect and lock out power source before adjusting or servicing.

WARNING

Use stump grinder only for the designed applications.

Any other use may result in personal injury, damage to equipment and may void the warranty.

WARNING

Prevent serious injury or death.

Verify stump grinder is attached to tractor before operation or transport.

Carefully read all safety messages in this manual and on equipment safety signs. Keep safety signs in good condition and replace missing or damaged safety signs.

New equipment components and repair parts must include the current safety decal.

Learn how to properly operate equipment. NEVER operate or work around this equipment without proper instruction, while fatigued or under the influence of alcohol, prescription or non-prescription medication or if feeling ill.

Keep your equipment in proper working condition.

Know the regulations and laws that apply to you and your industry. This manual is not to replace any regulations or laws. Additional information may be found at: www.asae.org or www.osha.gov.

If you do not understand any part of this manual, contact Baumalight at 866-820-7603.

Prepare for Emergencies

- Be prepared in case of emergencies.
- Keep a fire extinguisher and first aid kit close to the machine.
- Keep emergency phone numbers close to your phone.
- Know your address so emergency services can locate you if an emergency arises.

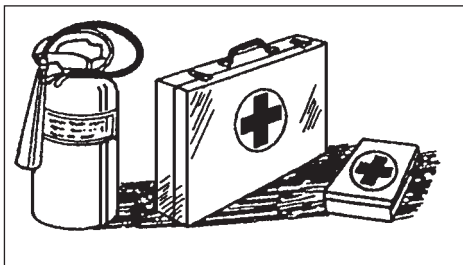

Replace Safety Signs

- Replace missing or damaged safety signs.
- Safety signs are identified in Section 3 of this manual.
- Replacement safety signs are available from your Baumalight dealer.

Do Not Allow Riders

- NEVER lift or carry anyone with stump grinder.
- NEVER use stump grinder as a work platform.
- NEVER allow passengers on stump grinder.

Lower Operating Speed

- Lower operating speed while loading, unloading or performing heavy operations.
- Keep load low and move at slow speeds on rough or uneven terrain.

Avoid Rollover

The equipment may rollover, resulting in death or serious injury. To help prevent rollover:

- Travel at a slow speed.
- Avoid sharp turns & sudden movement on slopes.
- Carry loads close to the ground.
- Avoid holes, ditches and other obstructions which may cause equipment to rollover.
- Balance load so weight is evenly distributed and load is stable.
- Use caution when operating on slopes and do not operate on excessively steep slopes.
- Do not exceed load capacity of equipment.

Avoid Powerlines & Underground Utilities

- Check clearance before raising equipment.
- Have local utilities locate and mark buried wires, cables, pipelines and other hazards before grinding.

DANGER

Prevent electrocution.

Death or serious injury can result if equipment comes near or contacts power lines.

Electrocution can occur without direct contact.

DO NOT leave the operator's seat if any part of the equipment contacts electric lines or cables.

Detach Stump Grinder Safely

Detach stump grinder on a firm and level surface. Stump grinder may fall over if detached on sloping or soft surface. Be sure people, livestock and pets are clear of machinery.

Relieve hydraulic pressure before disconnecting hydraulic hoses. See your tractor Operator's Manual.

Raised Attachment

WARNING

Crushing hazard.

Raised, unsupported stump grinder can fall, resulting in death or serious injury.

Never enter the area under a raised stump grinder unless properly supported.

A raised stump grinder can lower unexpectedly, resulting in death or serious injury.

NEVER enter area under a raised stump grinder unless stump grinder is properly and safely supported.

Lower stump grinder to ground, engage parking brake, shut off engine and remove key before servicing.

Avoid Loud Noise

WARNING

Prolonged exposure to loud noise can cause impairment or loss of hearing.

Wear a suitable hearing protective device such as earmuffs or earplugs to protect against objectionable or uncomfortable loud noises.

Hazards from Modifying Equipment

Do not make any alterations to your stump grinder. Altering the equipment may cause unsafe conditions and may void the manufacturer's warranty.

Stay Clear of Rotating Drivelines

WARNING

Entanglement in a rotating driveline can cause serious injury or death.

Keep tractor shields and driveline shields in place at all times. DO NOT operate without drive line guards.

DO NOT wear loose fitting clothing.

Avoid High Pressure Fluids

WARNING

Pressurized fluids can penetrate the skin.

Hydraulic hoses can fail from age, damage and exposure.

Use body and face protection while searching for leaks. A tiny, almost invisible leak can penetrate the skin, thereby requiring immediate medical attention.

Use wood or cardboard to detect hydraulic leaks, never use your hands.

Escaping fluid under pressure can penetrate the skin causing serious injury.

Prevent the hazard by relieving pressure (See tractor Operator's Manual.) before connecting or disconnecting hydraulic lines. Verify all connections are tight before applying pressure.

Search for leaks with a piece of cardboard or wood.

Protect hands and body from high pressure fluids. If an accident occurs, see a doctor immediately. Any fluid injected into the skin must be surgically removed within a few hours or serious infection may result.

Avoid Wood Dust Inhalation

WARNING

Wear an approved respirator (N95 Type as a minimum).

Follow local, state and federal regulations.

The health effects from exposure to wood dust are due to chemicals in the wood or chemical substances in the wood created by bacteria, fungi, or moulds.

2.3 Maintenance Hazards

Before servicing, park machine on a firm and level surface, set parking brake, chock wheels, and place a “Do Not Operate” tag on control panel. Read and understand this manual. If you do not understand any part of the manual, contact Baumalight at 866-820-7603.

Always wear face and/or eye protection, safety shoes, and other protective equipment appropriate for the job.

Do not make unauthorized modifications. Contact Baumalight at 866-820-7603 before you weld, cut/ drill holes, or make any other modifications.

Always use Baumalight replacement parts.

WARNING

Moving parts can crush and cut.

Keep clear of moving components.

Follow lockout procedure before servicing.

WARNING

Crushing hazard.

Before performing inspections, service or maintenance:

Park machine on firm, level surface.

Engage parking brake.

Turn engine off and remove key.

Place “Do Not Operate” tag on control panel.

WARNING

Entanglement hazard.

Keep clear of moving components.

Wear proper protective equipment appropriate for the job.

WARNING

Burn hazard.

Hot and high pressure hydraulic oil.

Allow oil to cool before servicing.

3. SAFETY SIGNS

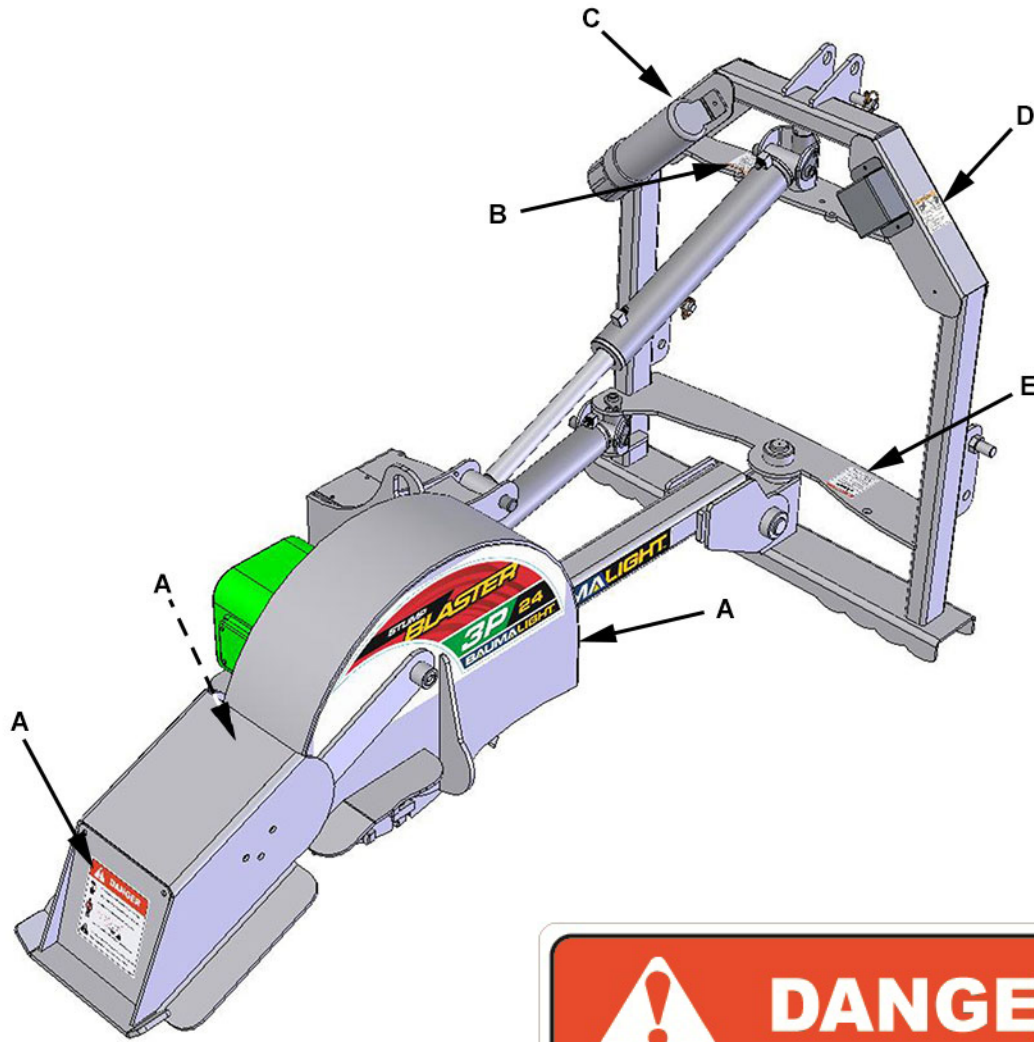

Dashes lines indicate items hidden from view.



A. MTB-108 Safety Sign



B. MTB-180 Safety Sign



D. MTB-182 Safety Sign

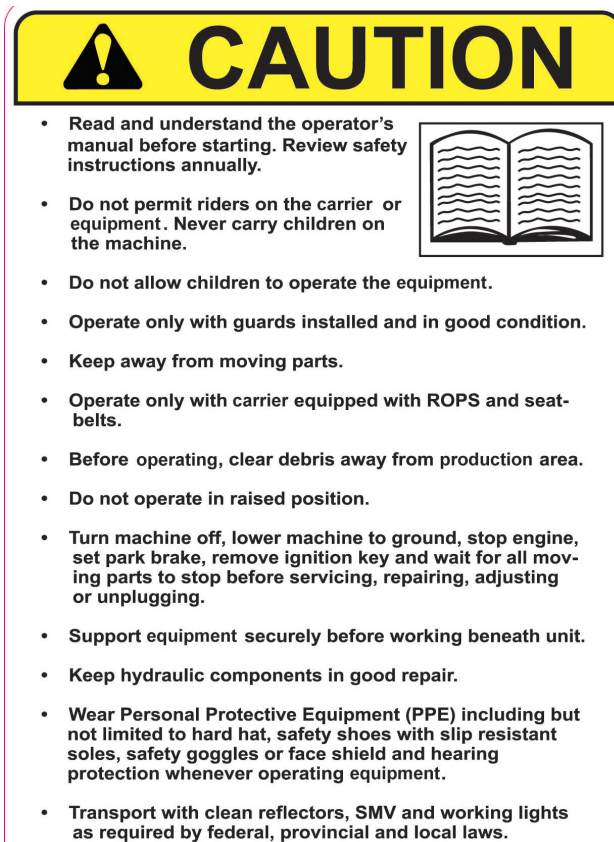

C. MTB-175 Safety Sign



E. MTB-179 Safety Sign

4. Assembly

4.1 Remove Stump Grinder From Pallet

⚠ WARNING

Approximate weight of grinder is:

- 3P24 - 642 lbs (291 kg)
- 3P34 - 1231 lbs (558 kg)
- 3P40 - 1280 lbs (581 kg)

Stump Grinder is top heavy when attached to pallet. Move with caution.

Do not position feet around or under pallet.

To prevent injury from accidental lowering of grinder, attach an adequate lifting device to lifting eye (A) on stump grinder.

1. Remove crate material from pallet.
2. Attach an adequate lifting device to lifting eye (A) on stump grinder.
3. Remove all shipping bands, wires and loose parts from around stump grinder.
4. Slowly lift the weight of stump grinder off the pallet. Remove pallet from work area.
5. Lower stump grinder, so that the stabilizing foot reaches the ground.
6. Stabilize the machine and continue lowering the rest of the way down.
7. Remove lifting device.

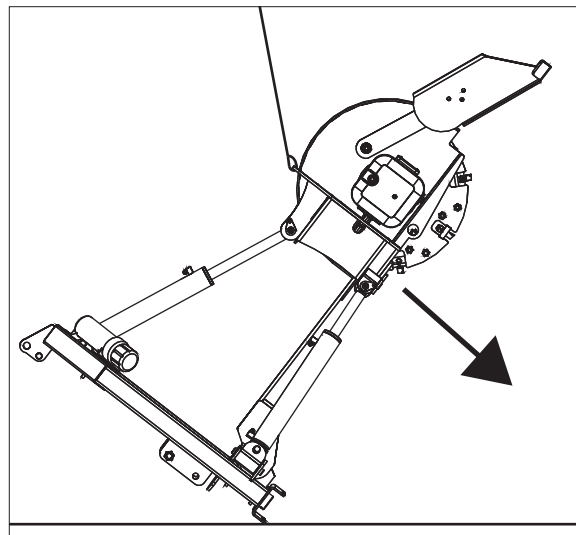
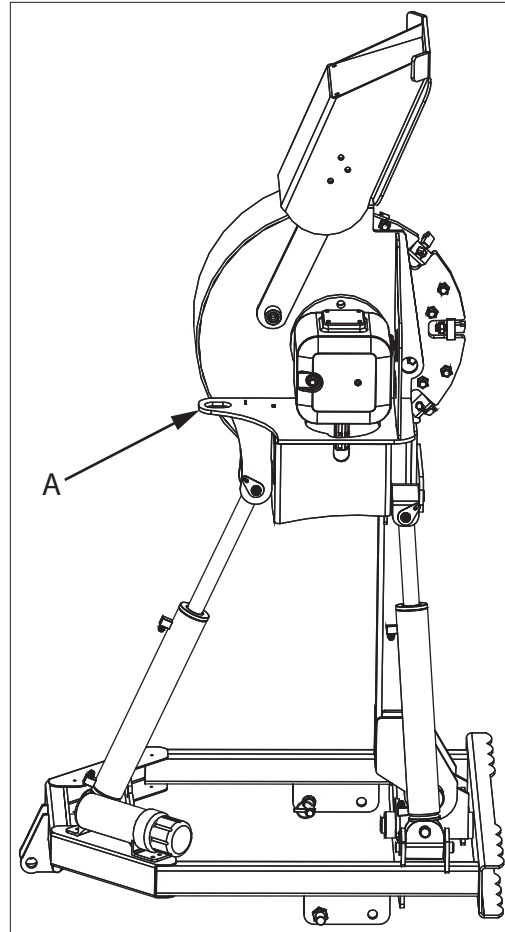

4.2 Attach Driveline

1. Remove four cap screws (A), washers and cover (B).
2. Remove nut and bolt from drive line.
3. Attach drive line (C) to gear box shaft (D).
4. Install nut and bolt in drive line.
5. Install cover, four washers and cap screws.
6. Attach safety shield chain (E) as shown.

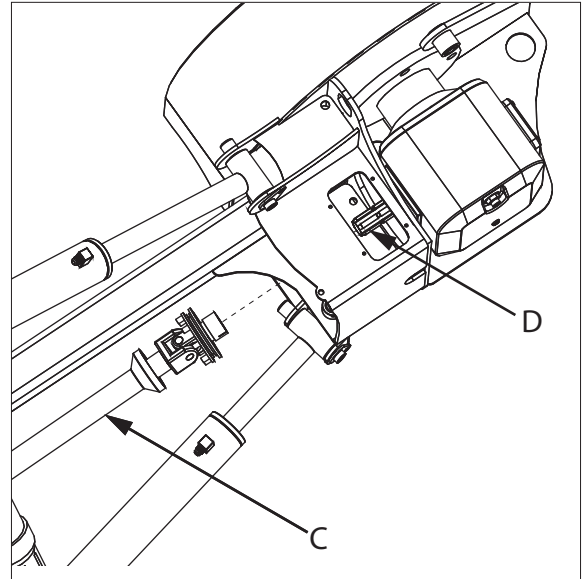
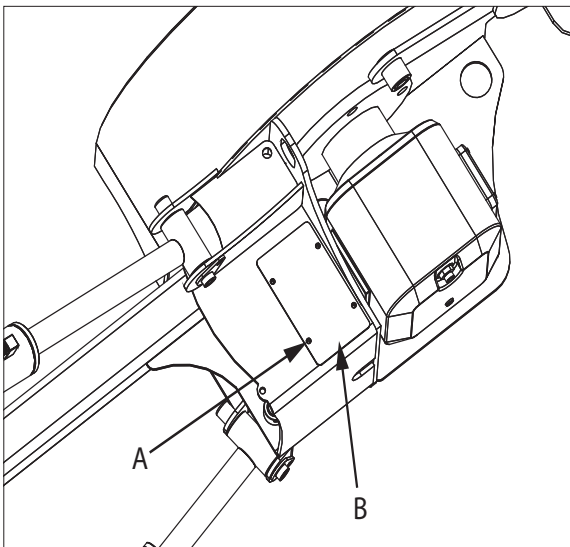

4.3 Driveline Dimension

To accompany the variety of 3 point hitch geometry available today, the driveline can be too long for some machines or too short for others. It is very important that the driveline be free to telescope but not to bottom out when going through its working range. If the driveline bottoms out, the bearings on both the machine and tractor PTO shaft will be overloaded and fail in a short time.

To determine the proper length of the driveline, follow this procedure:

1. Attach stump grinder to tractor but do not attach driveline.
2. Raise grinder until the input shaft is level with tractor PTO shaft.
3. Measure dimension (A) between locking grooves on tractor PTO shaft and grinder input shaft.
4. Measure same dimension (B) on compressed driveline.

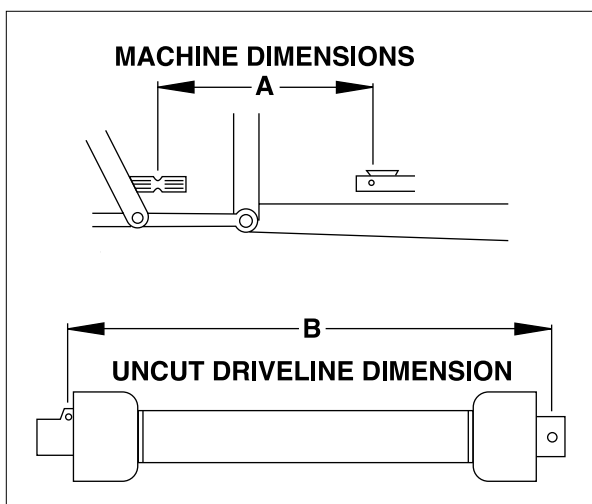

5. If compressed driveline dimension (B) exceeds the machine dimension (A), driveline must be cut.

When cutting driveline, follow this procedure:

1. Subtract machine dimension (A) from uncut driveline dimension (B). This dimension determines how much too long the driveline is.
2. Add 1 in. (25 mm) to the dimension to be sure it doesn't bottom out, to determine cut off dimension (C).
3. Use a hacksaw to cut dimension (C) from both ends. Cut both plastic tubes and metal cores.

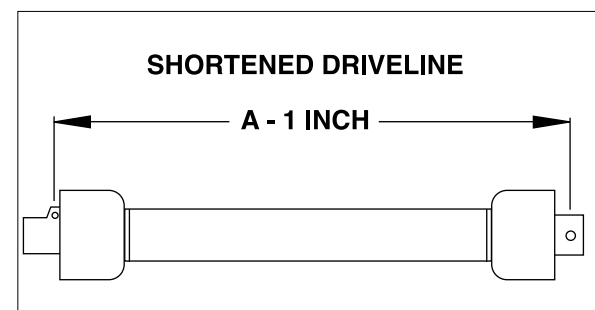
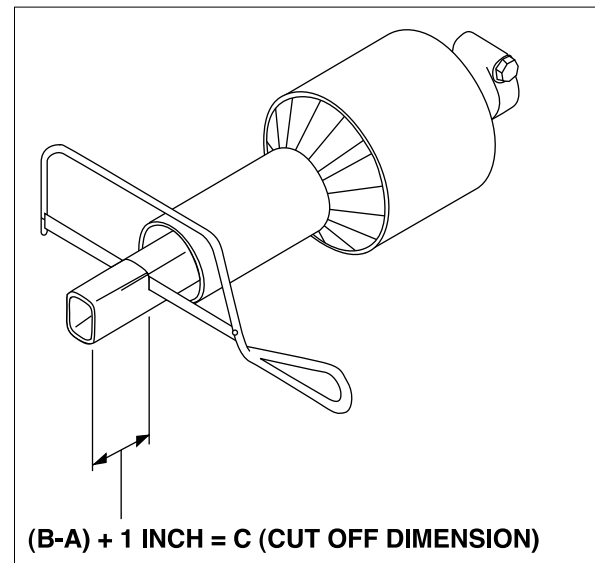

4. Use a file to remove burrs from cut edges.
5. Assemble shaft.
6. Make sure shaft can telescope freely. If it does not, separate and inspect for burrs or cuttings on shaft ends. Be sure it telescopes freely before installing.

5. OPERATION

5.1 Preparation For Use

WARNING

Wear an approved respirator (N95 Type as a minimum).

Follow local, state and federal regulations.

The health effects from exposure to wood dust are due to chemicals in the wood or chemical substances in the wood created by bacteria, fungi, or moulds.

Although the Stump Grinder has been carefully inspected and checked prior to shipment from manufacturer, it is recommended that the unit be thoroughly inspected.

Check all bolts for tightness and remove all shipping tags, bags, skids, and blocking. Check swing frame to ensure that it is free from obstruction and can operate smoothly without binding.

Remove any masking materials affixed during painting. Inspect the tractor and any accessory equipment to verify that nameplates and all safety warning, caution signs and decals provided with the equipment are in place and clearly visible.

Verify the three lynch pins are securely fastened.

Visually inspect the unit before each start up. Check for loose or missing parts and any damage that may have occurred during moving or shipping.

Review all tractor pre-start instructions, and ensure that all recommended steps and procedures have been followed. Never bar over the rotor, This could cause damage and result in personal injury or equipment damage.

NOTE: Always keep the weight of the machine in mind. Never position body in line of impact.

5.2 Pre-Operation Check List

Check-mark	Check these items:	Frequency
	Check the three lynch pins on the hitch to verify they are securely fastened.	Each operation.
	Check the hydraulic fluid level to verify there is sufficient fluid in the system.	Each operation.
	Check hydraulic lines for breaks and punctures.	Each operation.
	Verify hydraulic lines are plugged in securely.	Each operation.
	Verify hydraulic lines are tied well away and cannot bind or be pinched.	Each operation.
	Check the cross bolts that secure the 9 pivot pins.	Each operation.
	Verify the pins on each end of the drive shaft are secured.	Each operation.
	Verify the safety chains on the drive shaft are securely attached to the cover.	Each operation.
	Verify the cutting tips on the cutting wheel are tight.	Every 4 hours.
	Grease 2 pins on the deflector shield.	Every 6 hours.
	Grease all 9 pivot pins.	Every 10 hours.
	Check the oil in the stump grinder's gearbox. For type and quantity refer to the maintenance section.	Every 200 hours.

5.3 Machine Components

- A. Manual Storage Tube
- B. 3-Point Top Link
- C. 3-Point Lift pins
- D. Raise/Lower Cylinder
- E. Cutting Wheel Shield
- F. Debris Shield
- G. Cutting Wheel
- H. Gear Box
- I. Slip Clutch Shield
- J. Swing Cylinder
- K. Resting Foot
- L. Drive Line w/ Slip Clutch

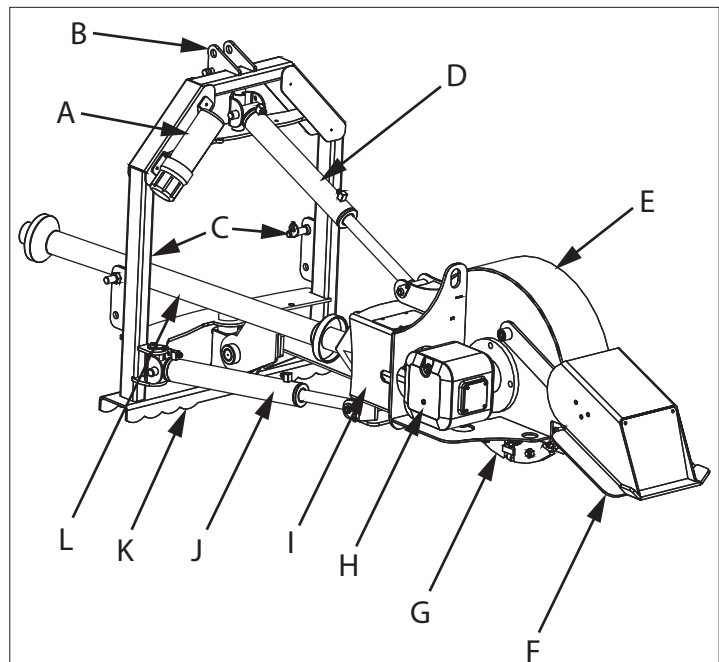

5.4 Attaching Stump Grinder To Tractor

⚠ WARNING

To prevent injury or machine damage put transmission in “Park” and check the full range of hitch for interference, binding or PTO separation.

Never position yourself between tractor and stump grinder.

Only experienced and properly trained operator’s should operate the tractor and stump grinder.

1. Back up tractor to stump grinder with hitch points approximately in alignment.
2. Engage tractor park brake and/or place transmission in “Park”.
3. Shut off engine and remove key.
4. Attach lower links to grinder and retain using lynch pins (A). To avoid machine damage, verify lynch pins are locked on lower links.
5. Align top link with hole in top of frame and retain with pin (C) and lynch pin (B). To avoid machine damage, verify lynch pin is locked on pin (C).
6. Pull collar (D) back toward the grinder. Align splines on tractor PTO shaft and drive line by rotating grinder drive line. Push drive line onto PTO shaft until it snaps into place.
7. Pull back on drive line to make sure it is locked on shaft.
8. Attach safety shield chain (E) as shown.

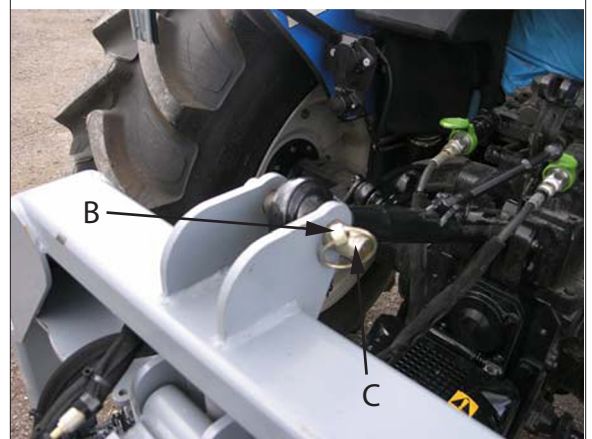

9. Plug in hydraulic hoses (F) to the tractor's rear SCV's. See your tractor Operator's Manual.



10. Verify hydraulic hoses are clear of pinch areas.
11. Retain hydraulic hoses to top bar of hitch. Verify hoses do not interfere with drive line.
12. Adjust top link so that the stump grinder A-frame is vertical to the ground.

⚠ WARNING

Pressurized fluids can penetrate the skin.

Hydraulic hoses can fail due to physical damage, age, kinks and exposure. Check hoses regularly. Replace damaged hoses.

Use body and face protection while searching for leaks. A tiny, almost invisible leak can penetrate the skin, thereby requiring immediate medical attention.

Use wood or cardboard to detect hydraulic leaks, never use your hands.

13. If equipped with S1050 Adapter Bracket - Remove lock pins from positions (G) and pivot S1050 adapter brackets to a comfortable operating position. Install lock pins at positions (G).

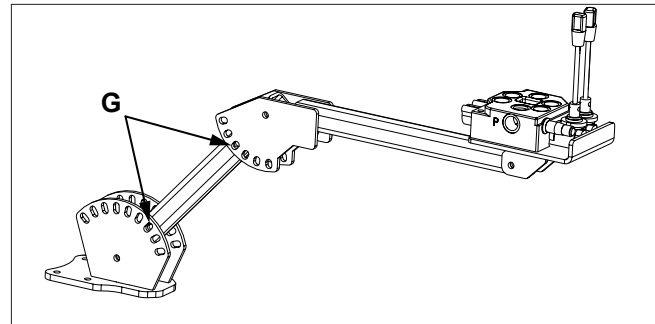

5.5 Detaching Stump Grinder From Tractor

⚠ WARNING

Prevent serious injury or death caused by unexpected movement:

1. Park tractor on a level surface.
2. Engage tractor park brake.
3. Disengage PTO.
4. Shut off engine and remove key.

1. Park tractor on a level surface.
2. Lower grinder to the ground.
3. Shut off engine and remove key.
4. Relieve hydraulic pressure. See your tractor Operator's Manual.
5. Disconnect hydraulic hoses (A).
6. Disconnect drive line safety chain (B).
7. Support drive line with your hand.
8. Pull collar (C) back toward grinder and slide off shaft.
9. Remove lynch pin (F) and pin (E).
10. Place top link in storage position.
11. Remove lynch pins (D) from both lower links.

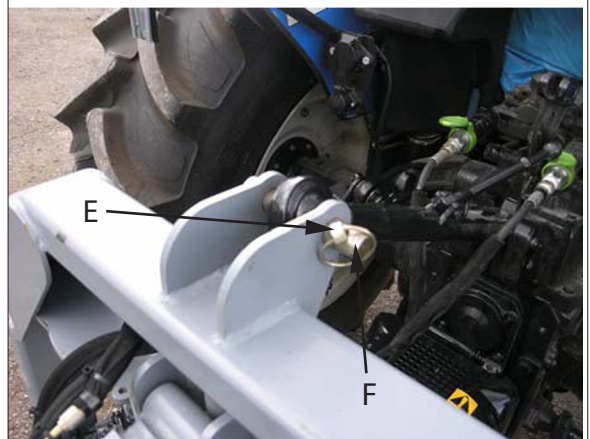
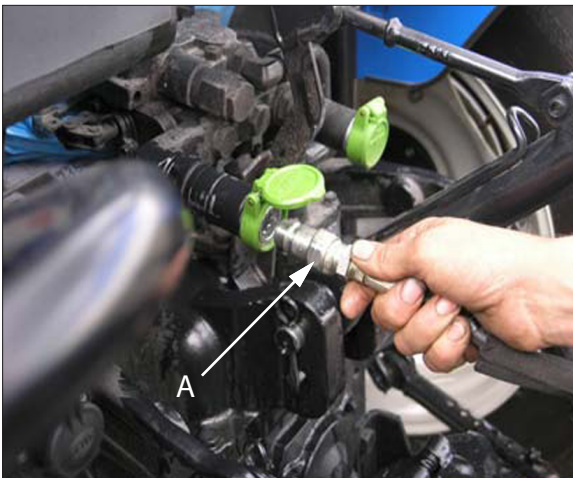

5.6 Transporting

1. Verify all reflectors and Slow Moving Vehicle (SMV) sign are visible.

⚠ WARNING

Prevent injury and equipment damage.

S1050 adapter bracket may contact operator or tractor when stump grinder is raised.

Place adapter bracket in fully retracted position before raising stump grinder.

2. If equipped with S1050 Adapter Bracket - Remove lock pins from positions (A) and pivot S1050 adapter bracket to the fully retracted position as shown. Install lock pins in positions (A).

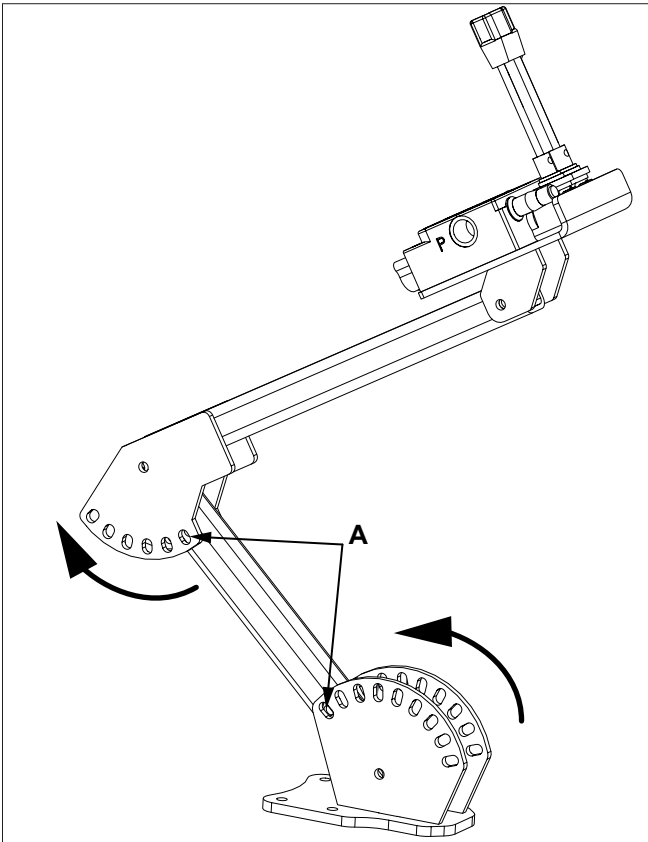

3. Raise stump grinder to fully raised position.
4. Center the grinder directly behind the tractor for greater stability.
5. Verify tractor PTO is disengaged.
6. Travel at a reasonable and safe speed.

⚠ WARNING

To prevent bodily injury from rotating cutting wheel, be sure to disengage PTO before transporting grinder.

5.7 Adjusting Swing Speed

1. The swing speed of the grinder can be adjusted by turning the adjustment knob (A) on the flow control valve. Do this with grinder in raised position.
2. To adjust the speed of the grinder to the slowest setting, turn the adjustment knob (A) until 1 is visible on the white stalk in the center of the knob. As you turn the knob, the stalk moves from 1 to 4, with 1 being the slowest speed and 4 the highest speed.
3. It is recommended to start at position 1. Adjust the speed up from that point.

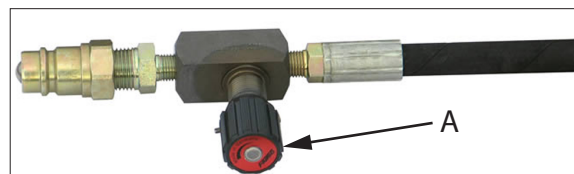

5.8 Carbide Teeth Break-In

During the first few hours of use, avoid hitting stones as much as possible to allow the carbide teeth to wear slightly. This can be done by keeping the cutting wheel above ground level. Brand new carbide tips are razor sharp and can chip and shatter easily when they hit hard objects. Once the razor sharpness has worn away, the tips do not chip as easily. Observing these precautions will extend the life of the carbide teeth and reduce operating expenses.

5.9 First Time User Tips

Before you begin, make sure the tractor is turned off and the PTO drive is disengaged.

Stand to the side of the stump grinder and observe the center point on the bottom of the cutting wheel. Now sit on the tractor seat and observe the center point again. This point will appear different depending on where you are positioned. This can be very deceiving! Familiarize yourself with the view of the stump grinder from the tractor seat.

Test all operating functions in an open area with the tractor at idle speed to get a feel for the controls. Take your time.

Start with a small stump. Make the first pass then disengage the PTO drive and get off the tractor to see how much you have removed.

Get off the tractor after each pass to check the progress. The cutting wheel is shielded from view when sitting on the tractor seat so it is difficult to accurately determine the progress. The ability to judge the positioning improves with practice. Do not expect to get the first stump done quickly.

WARNING

Always turn off the tractor and disengage the PTO drive before getting off the seat and approaching the cutting wheel.

WARNING

Wear an approved respirator (N95 Type as a minimum).

Follow local, state and federal regulations.

The health effects from exposure to wood dust are due to chemicals in the wood or chemical substances in the wood created by bacteria, fungi, or moulds.

5.10 Field Operation

WARNING

Entanglement in a rotating drive line can cause serious injury or death.

Keep tractor shields and drive line shields in place at all times. **DO NOT** operate without drive line guards.

DO NOT wear loose fitting clothing.

WARNING

Prevent serious injury or death caused by unexpected movement:

1. Park tractor on a level surface.
2. Engage tractor park brake.
3. Disengage PTO.
4. Shut off engine and remove key.

WARNING

Never operate tractor when other people are in the vicinity.

Do not allow riders on tractor.

WARNING

Never operate stump grinder when other people are in the vicinity. Debris can be thrown several feet from cutting area. Keep all shields in place.

WARNING

Clean machine thoroughly before service or maintenance procedures.

The health effects from exposure to wood dust are due to chemicals in the wood or chemical substances in the wood created by bacteria, fungi, or moulds.

1. Attach stump grinder to tractor. See Attaching Stump Grinder to Tractor in this section.
2. Adjust the stump grinder sweep speed. See Adjusting Swing Speed of Grinder in this section.

Note: All cutting is done on the left side of the cutting wheel, not the bottom of the wheel.

3. If the stump is on a grade, position tractor lower on the grade with the cutting wheel on the stump grinder higher up the grade.
4. Back the tractor up to the front edge of the stump (the edge that is closest to the tractor). Lower the foot of the A-frame on the stump grinder to rest squarely on the ground.

WARNING

Always turn off the tractor and disengage the PTO drive before getting off the seat and approaching the cutting wheel.

5. Disengage tractor PTO. Shut off engine and remove key.
6. Get off the seat and check the position of the stump grinder to the stump. Verify the grinder is positioned at the edge of the stump that is closest to the tractor.

Note: If you are working close to a fence or building, the deflector guard (A), that directs debris, can be flipped up.



⚠ WARNING

Raising the deflector guard can allow debris to travel a long distance. Be aware of your surroundings.

7. Using the lift and swing levers to direct the stump grinder, make the first pass across the front edge of the stump, moving the cutting wheel from right to left in 3 - 6 in. (76 - 152 mm) passes. The size of the pass will depend on the power and size of the tractor. Larger passes can be handled by a larger tractor. Return the grinder to the far right after each pass.
8. Continue to take passes across the front edge of the stump, taking 3 - 6 in. (76 - 152 mm) on each pass.
9. When ground level is reached, continue to grind 3 - 6 in. (76 - 152 mm) below the surface to the bottom of the stump where the roots branch out.
10. Lift the stump grinder and swing it to the far right. Back the tractor up slightly to position the stump grinder beside the new front edge of the stump.
11. Make multiple passes over the front edge of the stump, taking 3 - 6 in. (76 - 152 mm) on each pass.

12. Reposition the tractor and stump grinder as needed until the entire stump has been removed to below ground level.
13. Follow the roots, taking as much of the larger surface roots as possible. If these are not removed they can, over time, protrude from the ground in areas where there is a heavy freeze/thaw cycle.
14. Throttle down the tractor to an idle.
15. Disengage tractor PTO.
16. Shut off engine and remove key.
17. Get back on the tractor and turn it on. Engage the PTO drive. If the tractor is equipped with two remotes, use these levers to control lift and swing. If the stump grinder is equipped with the optional S1050 valve (B), use the levers on the valve to control lift and swing.

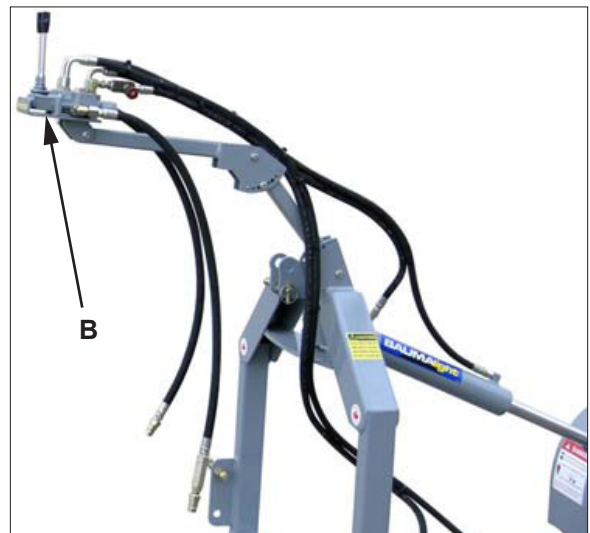

⚠ WARNING

Never approach stump grinder before cutting wheel has come to a complete stop.

6. SERVICE And MAINTENANCE

6.1 Service

⚠ WARNING

Pressurized fluids can penetrate the skin.

Hydraulic hoses can fail due to physical damage, age, kinks and exposure. Check hoses regularly. Replace damaged hoses.

Use body and face protection while searching for leaks. A tiny, almost invisible leak can penetrate the skin, thereby requiring immediate medical attention.

Use wood or cardboard to detect hydraulic leaks, never use your hands.

Prevent the hazard by relieving pressure (See tractor Operator's Manual.) before connecting or disconnecting hydraulic lines. Verify all connections are tight before applying pressure.

Protect hands and body from high pressure fluids. If an accident occurs, see a doctor immediately. Any fluid injected into the skin must be surgically removed within a few hours or serious infection may result.

⚠ WARNING

Prevent serious injury or death caused by unexpected movement:

1. Park tractor on a level surface.
2. Engage tractor park brake.
3. Disengage PTO.
4. Shut off engine and remove key.

⚠ WARNING

Clean machine thoroughly before service or maintenance procedures.

The health effects from exposure to wood dust are due to chemicals in the wood or chemical substances in the wood created by bacteria, fungi, or moulds.

6.1.1 Replace Cutting Teeth

1. Park tractor and grinder on a level surface.
2. Lower grinder to the ground.
3. Support grinder frame with safety stands.
4. Shut off engine and remove key.
5. Inspect cutting teeth for damage. Replace individual teeth as needed.
6. Remove lock nut (A) and cutting tooth (B).
7. Install replacement tooth and lock nut. Tighten lock nut (A) to 150 lb/ft (204 Nm) of torque.

Note: Parts breakdown can be found on Baumalight's website. www.baumalight.com

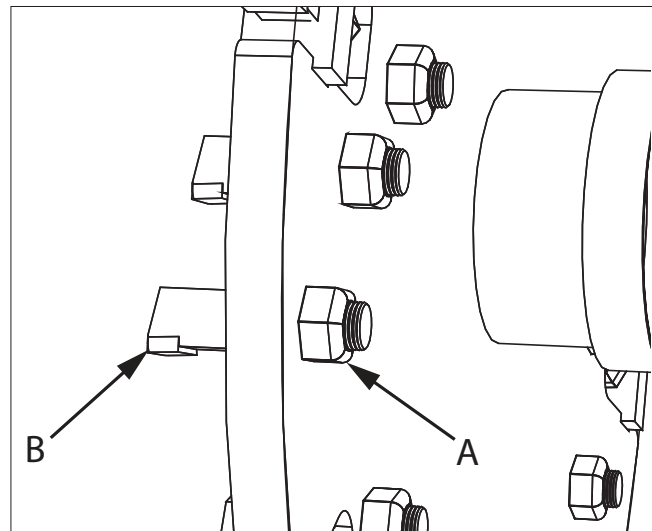

6.1.2 Replace Hydraulic Hoses

1. Park tractor and grinder on a level surface.
2. Lower grinder to the ground.
3. Place wood block under cutting wheel and lower cutting wheel to wood block.
4. Shut off engine and remove key.
5. Relieve hydraulic pressure. See your tractor Operator's Manual.
6. Remove hose (B) from cylinder.
7. Remove quick coupler and/or adapter (A) from hose.
8. Install replacement hose in reverse order of removal.

Note: Parts breakdown can be found on Baumalight's website. www.baumalight.com

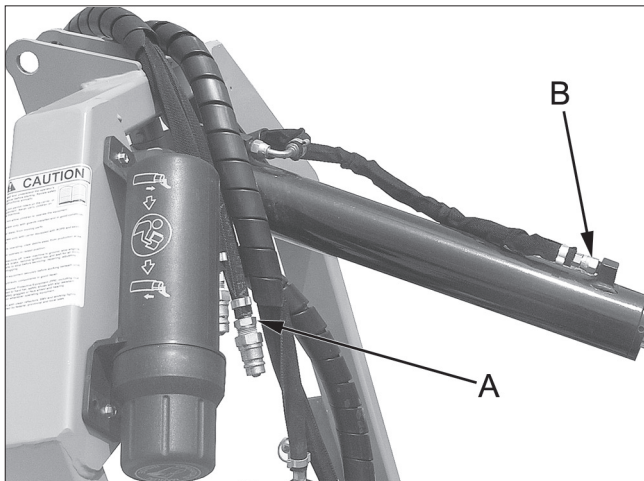

6.1.3 Adjust Slip Clutch

⚠ WARNING

Entanglement in a rotating drive line can cause serious injury or death.

Disconnect and lockout power source before adjusting or servicing.

⚠ CAUTION

Slip clutch may be hot. Wait for clutch to cool before adjusting or servicing.

Bondioli Driveshafts

4-Disk 120 Hp 1,000 rpm

- OEM Part Number
 - 71R8121UCKR80V6
- Dimension A - 0.236 in. (6 mm)
- Dimension B - 1.12 in. (28.5 mm)

4-Disk 165 Hp 1,000 rpm

- OEM Part Number
 - CSHN086U2R100W8
- Dimension A - 0.275 in. (7 mm)
- Dimension B - 1.14 in. (29 mm)

Binacchi Drivehafts

2-Disk 68 Hp 540 rpm

- OEM Part Number
 - B6140EA60255
 - B6N121USA60255
- Dimension A - 0.236 in. (6 mm)
- Dimension B - 1.1 in. (28 mm)

4-Disk 80 Hp 540 rpm

- OEM Part Number
 - B8N111USA60307
 - B8#140EA60307
- Dimension A - 0.275 in. (7 mm)
- Dimension B - 1.15 in. (29 mm)

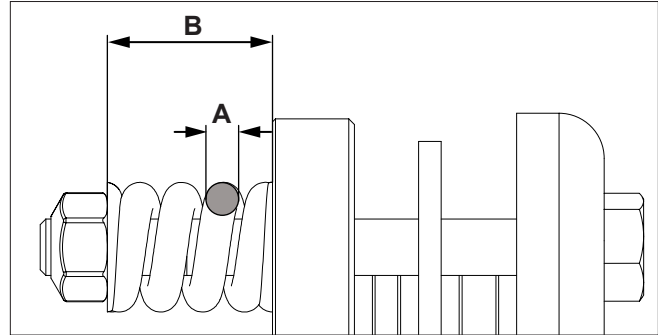

6.2 Maintenance

Maintenance Chart		
General Inspection	Inspect the unit for any buildup of contamination (dirt, stones, etc.).	Daily
Hydraulics	Check hydraulic hoses and fittings for leaks.	Daily
Cutting Teeth	Check and replace one at a time as necessary. The teeth on the outer edge of the wheel wear faster and are more prone to chipping. With daily use expect to replace 5 to 10 teeth per week. (See Replace Cutting Teeth in this section.)	Every 2 hours.
Deflector Shield Pins	Lubricate pins so deflector can move freely.	Every 6 hours.
Pivot Pins	Lubricate nine (9) pivot pins.	Every 10 hours.
Gearbox Oil	Change gear box oil. Use synthetic 90W gear oil. Capacity is 1.5 L (1.5 qts.).	Every 200 hours.
Cutting Wheel Retaining Nut	Torque to 176-190 N•m (130-140 lb-ft.)	Only if cutting wheel is replaced.

6.2.1 Every 6 Hours

Lubricate deflector shield pivot points every 6 hours of use.

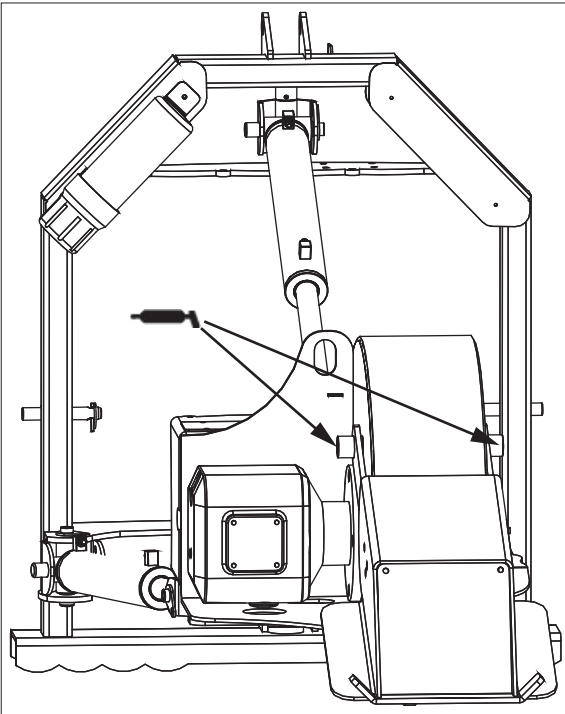

6.2.2 Every 10 Hours

Lubricate pivot pins every 10 hours of use.

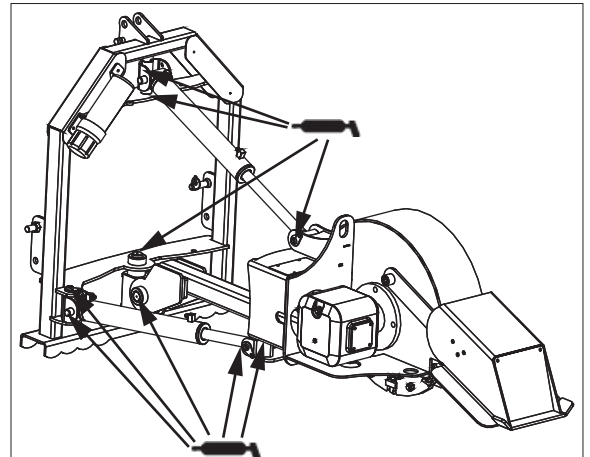

6.2.3 Every 200 Hours

1. Park tractor and grinder on a level surface.
2. Lower grinder to the ground.
3. Place wood block under cutting wheel and lower cutting wheel to wood block.
4. Shut off engine and remove key.
1. Remove drain plug (A).
2. Drain oil and install plug.
3. Remove fill/check plug (B).
4. Add synthetic 90W gear oil until oil comes out of hole.
5. Replace fill/check plug.

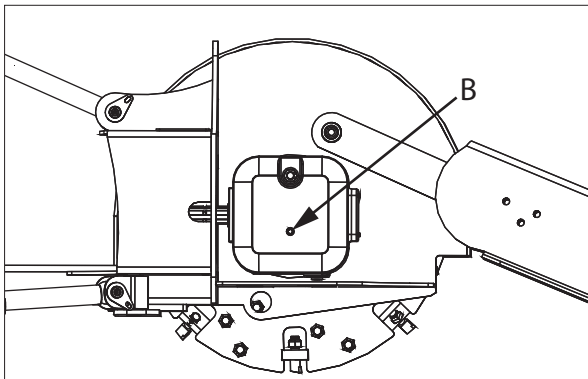
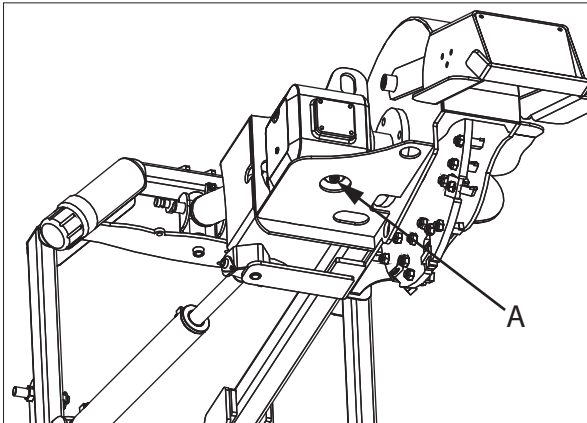

7. TROUBLESHOOTING

PROBLEM	CHECK	SOLUTION
Cutting wheel does not spin.	Cutting wheel jammed.	Remove material from cutting wheel.
	Verify PTO drive line is connected properly.	Connect drive line to tractor.
	Slip clutch is slipping.	Remove jam from cutting wheel.
Cutting wheel does not have much power.	Slip clutch is slipping.	<p>Check to determine if the slip clutch is hot. Use Caution: This Can Be Very Hot! A hot clutch does NOT grip.</p> <p>Slippage on the clutch occurs if there is more power than the unit is rated for: Model 3P24 is rated for 20-60 hp input. Model 3P34 is rated for 50-80 hp input. A bigger tractor can be used if it is idled down as this will decrease the output power of the engine.</p> <p>Take smaller passes (less cutting) to decrease the strain on the clutch.</p> <p>Turn the flow control knob to a lower number (1) to reduce the strain on the slip clutch.</p> <p>Be careful when tightening the tension setting on the slip clutch as this could put excess strain on the gear box.</p>
Tractor is not able to lift 3-point.	Tractor is too small.	Move link pins to the top position on the stump grinder to add leverage.
Cutting wheel cannot be lifted high enough.	Stump too tall.	<p>Cut stump shorter.</p> <p>Shorten top link on 3-point hitch.</p>
Cutting wheel cannot be lowered far enough.	Top link not correct length.	Lengthen top link on 3-point hitch.
No movement on cylinders.	No oil flow.	Check for plugged or reversed hydraulic lines.
	Adjustment valve is closed.	Open adjustment valve.

8. STORAGE

8.1 Storing Grinder (End of Season)

1. Store Grinder in a dry place.
2. Clean grinder thoroughly. Dirt and wood chips will draw moisture and cause rust.
3. Lubricate machine. (See Service and Maintenance section.)
4. Check condition of cutting teeth. Replace as necessary. (See Service and Maintenance section.)
5. Loosen all lock nuts on drive line slip clutch. (See Service and Maintenance section.)
6. Check for loose or missing hardware.
7. Paint parts as necessary.
8. Store PTO drive line off the ground.

8.2 Removing Grinder From Storage (Beginning of Season)

1. Review Operator's manual and check adjustments.
2. Lubricate machine. (See Service and Maintenance section.)
3. Check gear box oil level. Fill as necessary. (See Service and Maintenance section.)
4. Inspect clutch linings and repair as necessary. Adjust slip clutch. (See Service and Maintenance section.)
5. If parts have been replaced, verify they run properly.

9. WARRANTY

This product is warranted to be free of defects in materials and workmanship under normal use and service, for a period of one year from the date of purchase, when operated and maintained in accordance with the Operating and Maintenance Instructions supplied with this unit. This warranty does not cover misuse or negligence.

Under no circumstances will the manufacturer be liable for any consequential damage or expense of any kind, including loss of profits. The manufacturer is under no circumstances liable for tractor damage of any kind. The manufacturer is not liable for the maintenance of the product.

This warranty is extended only to the original purchaser. Warranty is void if repairs are attempted by anyone other than an Authorized Service Center.

If a difficulty develops with the product, you should contact your nearest Authorized Repair Centre, or distributor. Only these locations are authorized to make repairs to the product or affect the replacement of defective parts, which will be done at no charge within a reasonable time after the receipt of the product. Units or parts should be returned at the customer's expense to the nearest repair location or Authorized Service Centre. Pack unit in a strong carton and pad tightly to avoid damage. Damage in-transit is not covered by warranty. Include original purchase receipt with any claim (keeping a copy for your files).

The Manufacturer's Liability is limited to repair of the product and/or replacement of parts and is given to the purchaser in lieu of all other remedies including incidental and consequential charges. There are no warranties, expressed or implied other than those specified herein. For the nearest Authorized Service Centre call the manufacturer.

Please note the following details and file this information in an appropriate place.

Model Number: _____ S/N: _____

Date of Purchase: _____ Owner's Name _____

MTB MFG INC.
CORPORATE HEADQUARTERS
4575 Powell Rd.,
Wallenstein, Ontario Canada
N0B 2S0
Phone - 519.698.9864
Toll Free - 866.820.7603
Fax - 519.698.1087
www.baumalight.com

