

For use with models having serial numbers with "D" as the **FIFTH** digit:
Example: T620**D**0000

2000 Series Tree Cutter

ATTENTION:
ALL WARRANTY WORK **MUST** BE APPROVED
BY BROWN MFG. CORP.
BEFORE WORK BEGINS



Owner / Operator Manual



HEAVY DUTY SINCE 1944

6001 E. Hwy 27 - Ozark, AL 36360
334.795.6603 - Fax: 334.795.3029

www.brownmfgcorp.com

WARNING

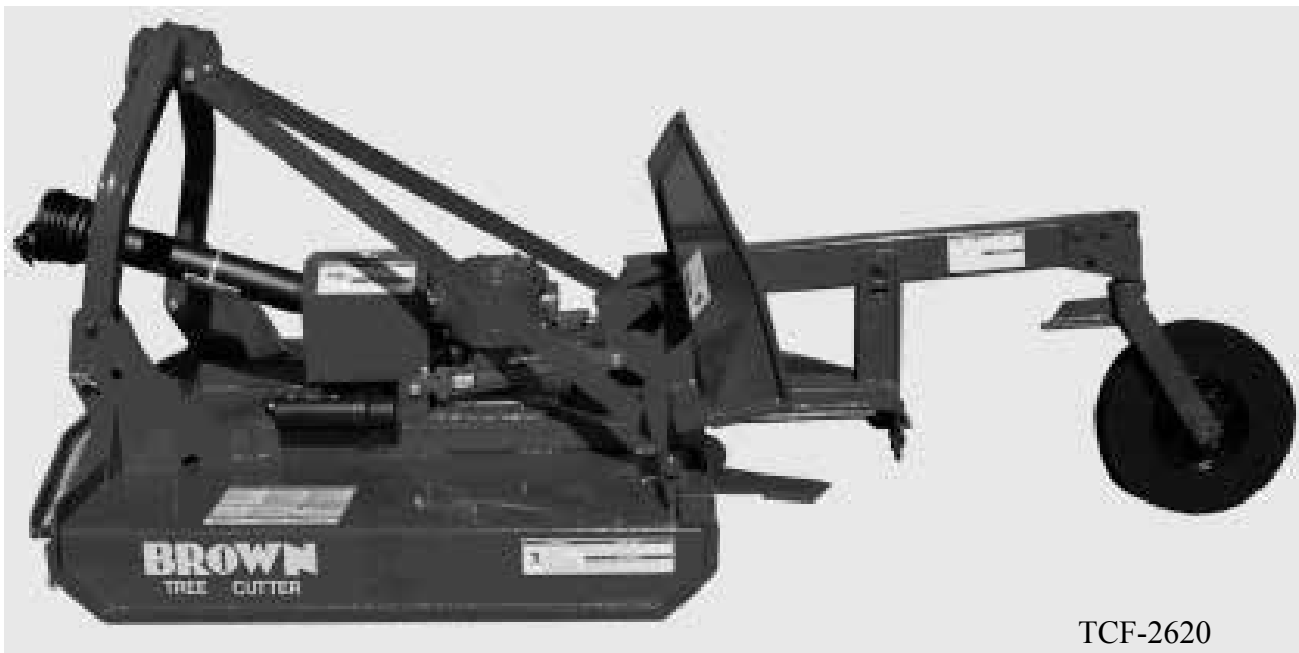

Before operating your machine, stop and read this owners manual. Do not attempt to operate the unit until you fully understand the material covered in this manual. Without the knowledge contained in this manual, injury or death can result.

**Copyright Information**

Copyright ©2005 Brown Manufacturing Corporation, Ozark, Alabama. All photos and illustrations are property of Brown Manufacturing Corporation. This publication may be freely reproduced, either in whole or in part, provided that the content herein is not altered. We encourage you to make copies of this manual and to distribute it to every operator of the machine. Additional copies are also available from Brown Manufacturing Corporation at no charge.

Cover

Illustrated: Model TC0-2620C Tree Cutter.

Disclaimer

Due to engineering improvements and revision of product specifications, the information contained in this manual is subject to change without notice.

Contents

Warranty.....	4
Registration.....	5
Equipment Safety.....	7
Assembly.....	18
Operation.....	21
Maintenance.....	31
Troubleshooting.....	44
Specifications.....	45
Replacement Parts.....	46

Warranty Statement

LIMITED WARRANTY

BROWN MANUFACTURING CORP. hereby warrants that Brown's products will be free from defects in material and workmanship under normal use according to the provisions and limitations herein set forth. All parts, specifically EXCLUDING expendable 'wear' parts, that become unserviceable, due to defective material or workmanship, within three months / 90 days from date of the original retail purchase, shall, at Brown's option, be repaired or replaced. **Refer to page 5, for further information on Right of Way equipment warranty.**

LIMITATIONS

The obligations of Brown for breach of warranty shall be limited to products manufactured by Brown; (1) that are installed, operated, and maintained according to Brown's instruction furnished and/or available to the purchaser upon request; (2) that are installed according to all other applicable Federal, State, and local codes or regulations; and (3) that the purchaser substantiates were defective in material and workmanship notwithstanding that they were properly installed and correctly maintained as set forth and were not abused or misused. The obligation of Brown shall be limited to replacing or repairing the defective product, at the option of Brown. Brown shall not be responsible for any labor or cost of removal or repairing or reinstallation of its products and shall not be liable for transportation costs to and from its plant in Ozark, Alabama. Use of parts for modification or repair of the product or any component part thereof not authorized or manufactured by Brown specifically for such product shall void this warranty. This warranty shall not apply to any damage to or defect in the Brown's products that is directly or indirectly caused by; (1) FORCE MAJEURE, act of GOD, or other accident not related to an inherent product defect; or (2) abuse, misuse, or neglect of the such product, including any damage caused by improper assembly, installation, adjustment, or faulty instruction of the purchaser. **OTHER THAN AS EXPRESSLY SET FORTH HEREINABOVE, BROWN MAKES NO OTHER WARRANTY, EXPRESS OR IMPLIED, WITH RESPECT TO ANY OF BROWN'S PRODUCTS, INCLUDED BUT NOT LIMITED TO ANY MERCHANTABILITY OR FITNESS FOR A PARTICULAR PURPOSE. IN NO EVENT SHALL BROWN BE RESPONSIBLE FOR ANY INCIDENTAL OR CONSEQUENTIAL DAMAGES OF ANY NATURE SUFFERED BY PURCHASER OR ANY OTHER PERSON OR ENTITY CAUSED IN WHOLE OR IN PART BY ANY OF BROWN'S PRODUCTS.** Any person or entity to whom this warranty extends and who claims breach of warranty against Brown must bring suit thereon within one year from the date of occurrence of such breach of warranty or be forever barred from any and all legal or other remedies for such breach of warranty. Brown is not responsible for and hereby disclaims any undertaking, representation, or warranty made by any dealer, distributor, or other person that is inconsistent with or in any way more expensive than the provisions of this limited warranty. This warranty grants specific legal rights and shall be read in conformity with applicable state law. In some jurisdictions, the applicable law mandates warranty provisions that provide greater rights than those provided for herein. In such case, this limited warranty shall be read to include such mandates provisions; and any provision herein that is prohibited or unenforceable in any such jurisdiction shall, as to such jurisdiction, be ineffective to the extent of such prohibition or unenforceable without invalidating the remaining provisions and without affecting the validity or enforceability of such provisions in any other jurisdiction.

STATEMENT OF POLICY

In accordance with our established policy of constant improvement, we reserve the right to amend these specifications at any time without notice.

WARRANTY BY MANUFACTURER

Dealer/distributor understands and agrees that the manufacturer extends only the following warranty to its customers. In the event dealer/distributor extends any additional warranty such as enlarging the scope or period of warranty or undertaking a warranty of fitness for any particular purpose or obligation not encompassed in manufacturer's warranty, dealer/distributor shall be solely responsible therefore and shall have no recourse against manufacturer with respect thereto.

Owner Registration

WARRANTY NOTES

- All parts returned to Brown Manufacturing Corp. for warranty inspection must be received freight prepaid.
- If a warranty claim is approved, replacement or repaired parts will be returned to the customer freight prepaid.
- If a dealer makes any type of approved warranty repair, only parts and labor will be credited by Brown Manufacturing Corp. **No service call or transportation charges are warrantable.**
- No returned parts will be inspected for warranty claims if not received with a Return Authorization Number. **Without a RA#, Brown Manufacturing Corp. cannot and will not be responsible for any returned goods.**
- Drive shaft / slip clutch/gear box warranties:** Right of Way Cutters: All new Brown Tree Cutters shipped with mechanical clutch drive shafts have a 90 day warranty. All new Brown Tree Cutters shipped with a friction clutch drive shaft have NO warranty.
- Use of any replacement parts other than original Brown replacement parts will void all warranties.**

⚠WARNING: The use of aftermarket replacement parts will change the operational conditions of the machine, shorten the life of other components, lead to failure of the machine, and create safety hazards to all persons near the machine. Brown equipment is designed to use original manufacturer replacement parts meeting the exact specifications of the machine and crafted from high-quality materials. Aftermarket replacement parts are neither engineered to meet the machine's exact specifications nor manufactured to the same high standards as original Brown replacement parts.

For Your Records

Model: _____
 Serial No.: _____
 Date Purchased: ___/___/___
 Dealer: _____
 Date Registered: ___/___/___

Owner Registration



Important: To place the manufacturer's warranty into effect, this card must be mailed within thirty (30) days after receiving equipment.

Return to:
 Brown Manufacturing Corp.
 6001 E. Hwy 27
 Ozark, AL 36360

Name: _____
 Address: _____
 City: _____ State: _____
 Model: _____
 Serial No.: _ _ _ _ _ C _ _ _ _ _
 Date Purchased: ___/___/___
 Dealer: _____

IMPORTANT NOTICE:
OWNER'S MANUAL STORAGE CONTAINER

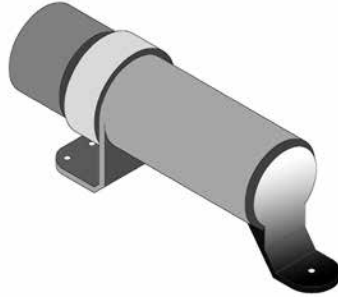

- * Brown Manufacturing provides an Owner's Manual storage container on all equipment.
- *This holder is mounted in a convenient location and provides the owner with the proper safety and operation information.
- *Two (2) copies are provided with each unit.
- *One copy is for the **owner** to have at office for review and maintenance of the equipment.
- *Second copy is to stay with the unit at all times. This will provide the **operator** the information needed for safe and proper operation of the unit.
- *If the Owner's Manual becomes lost or damaged, contact Brown Manufacturing Corp. or your local Brown dealer for free replacement. The manual is also available for digital download from our website; www.brownmfgcorp.com.

Please use envelope.

Equipment Safety



Warning: Read this manual before operation.

Operators of the equipment must read and understand this manual. Failure to read this manual and follow these safety and operating instructions could result in serious bodily injury or even death.

WARNING



Before operating your machine, stop and read this owners manual. Do not attempt to operate the unit until you fully understand the material covered in this manual. Without the knowledge contained in this manual, injury or death can result.

Each operator of the equipment should review this manual every six (6) months. You are encouraged to duplicate this manual and to distribute it to each operator of the equipment for their training and reference. Additional copies are available from Brown Manufacturing Corporation at no charge.

Equipment Safety

Recognize safety information

This is the safety alert symbol. When you see this symbol on your equipment or in this manual, be alert to the potential for personal injury or injury to others.



Understand signal words

DANGER indicates an imminently hazardous situation which, if not avoided, will result in death or serious injury



WARNING indicates a hazardous situation which, if not avoided, could result in serious injury or death.



CAUTION indicates a potentially hazardous situation which, if not avoided, may result in minor or moderate injury.



NOTICE indicates information considered important but not directly hazard related. (e.g. security, hygiene, equipment or property damage).



Follow safety instructions

- Read owner/operator manual.
- Replace missing or damaged safety decals.
- Safety decals and this manual must be considered a permanent part of your equipment.
- Should ownership of the equipment be transferred, this manual must also be transferred.
- Unauthorized modifications to the equipment are not recommended. This could impair the function, safety, and life of the machine.
- For any part of this manual that you do not understand, contact your dealer or Brown Manufacturing Corporation at (800) 633-8909.
- All implements with moving parts are potentially dangerous. Due to this fact, there is no substitute for a safe, knowledgeable operator. It is important that all persons operating this equipment read, understand, and follow the instructions provided in this manual.

DO NOT OPERATE THIS UNIT IF YOU ARE UNDER THE INFLUENCE OF ALCOHOL, ILLEGAL DRUGS, OR ANY PRESCRIPTION OR OVER THE COUNTER MEDICATIONS THAT COULD CAUSE DROWSINESS, DIZZINESS, DISORIENTATION AND/OR IMPAIR YOUR ABILITY IN ANY WAY TO SAFELY OPERATE THE UNIT.

DO NOT OPERATE THIS UNIT IF YOU SUFFER FROM ANY PHYSICAL CONDITON OR DISABILITY THAT WOULD IMPAIR YOUR ABILITY TO OPERATE IT SAFELY.

Equipment Safety

Safety Decals

The following safety decals should be attached to the equipment at all times. Should any decals become damaged or lost, it is the responsibility of the owner to replace it. Additional decals may be obtained from the dealer or Brown Manufacturing Corporation at no charge.

! WARNING	! ADVERTENCIA
	Antes de probar la unidad por primera vez deben remitirse a las instrucciones contenidas en el manual.
Read and understand owner's manual before operating unit.	! ADVERTISSEMENT
	S'assurer de bien comprendre toutes les consignes du manuel de propriétaire avant d'utiliser la unité.

Part No.: SD-010.

! DANGER
THROWN OBJECT HAZARD

<p>To prevent serious injury or death from thrown objects:</p> <ul style="list-style-type: none"> •Stay clear when blade is turning. •Operate only with all guards installed and in good condition. •Stop operation if bystanders come within several hundred feet.

Part No.: SD-001A.

! WARNING
<p>To prevent serious injury or death:</p> <ul style="list-style-type: none"> •Operate only at 540 RPM PTO. •Keep guards and shields in place.

SD-007A, Standard models*

! WARNING
<p>To prevent serious injury or death:</p> <ul style="list-style-type: none"> •Operate only at 1000 RPM PTO. •Keep guards and shields

SD-008A, Standard models*

Equipment Safety

Safety Decals (continued)



Part No.: DC-3-5-018.

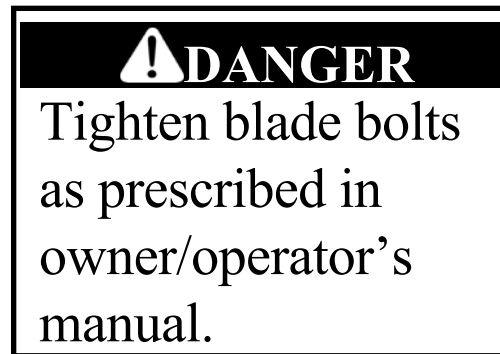

Part NO.: SD-002.

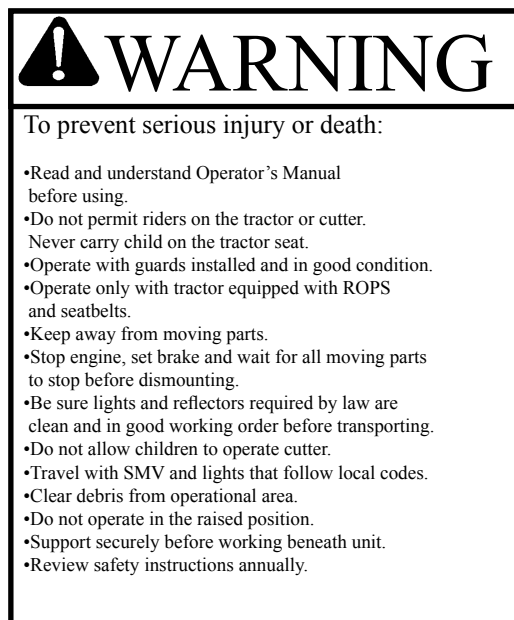

Part No.: SD-009A.



Part No.: SD-SW2.

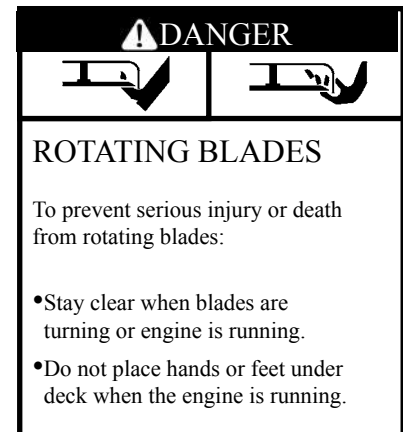

Part No.: SD-005A.



Part No.: SD-006A.

Equipment Safety

Safety Decals (Folding Deck Models)

Safety decals must be positioned as illustrated below. Use this diagram to correctly identify missing, damaged, or illegible decals for replacement.

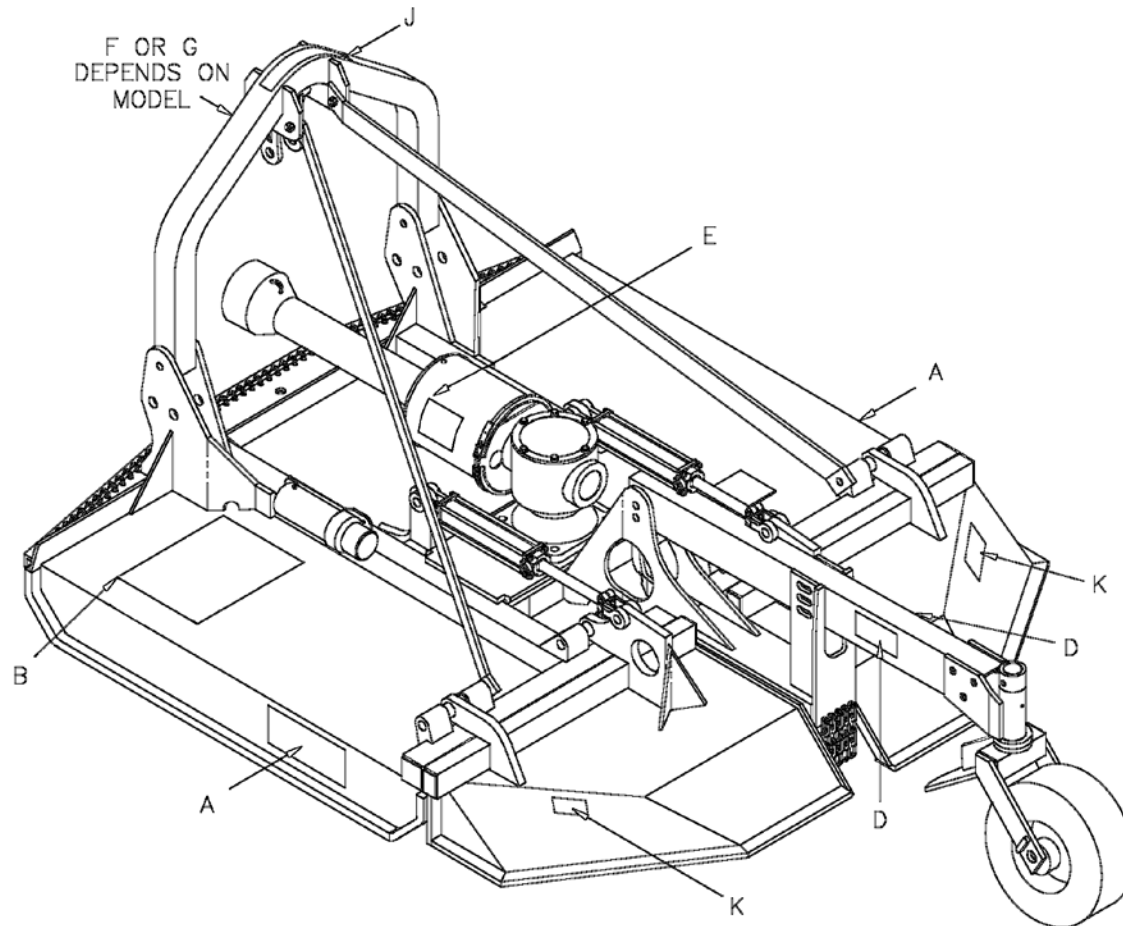

Ref. No.	Part No.	Description
A	SD-001A	Safety Decal: Thrown object hazard (2 req.)
B	SDL-020	Safety Decal: Lexan Combo
D	SD-005A	Safety Decal: Rotating blades (2 req.)
E	SD-006A	Safety Decal: Rotating driveline (2 req.)
F	SD-007A	Safety Decal: Operate at 540 RPM
G	SD-008A	Safety Decal: Operate at 1000 RPM.
J	SD-011A	Safety Decal: Missing deflector hazard
K	SW-202	Safety Decal: Frame pinch point

Equipment Safety

Safety Decals (Open Deck Models)

Safety decals must be positioned as illustrated below. Use this diagram to correctly identify missing, damaged, or illegible decals for replacement.

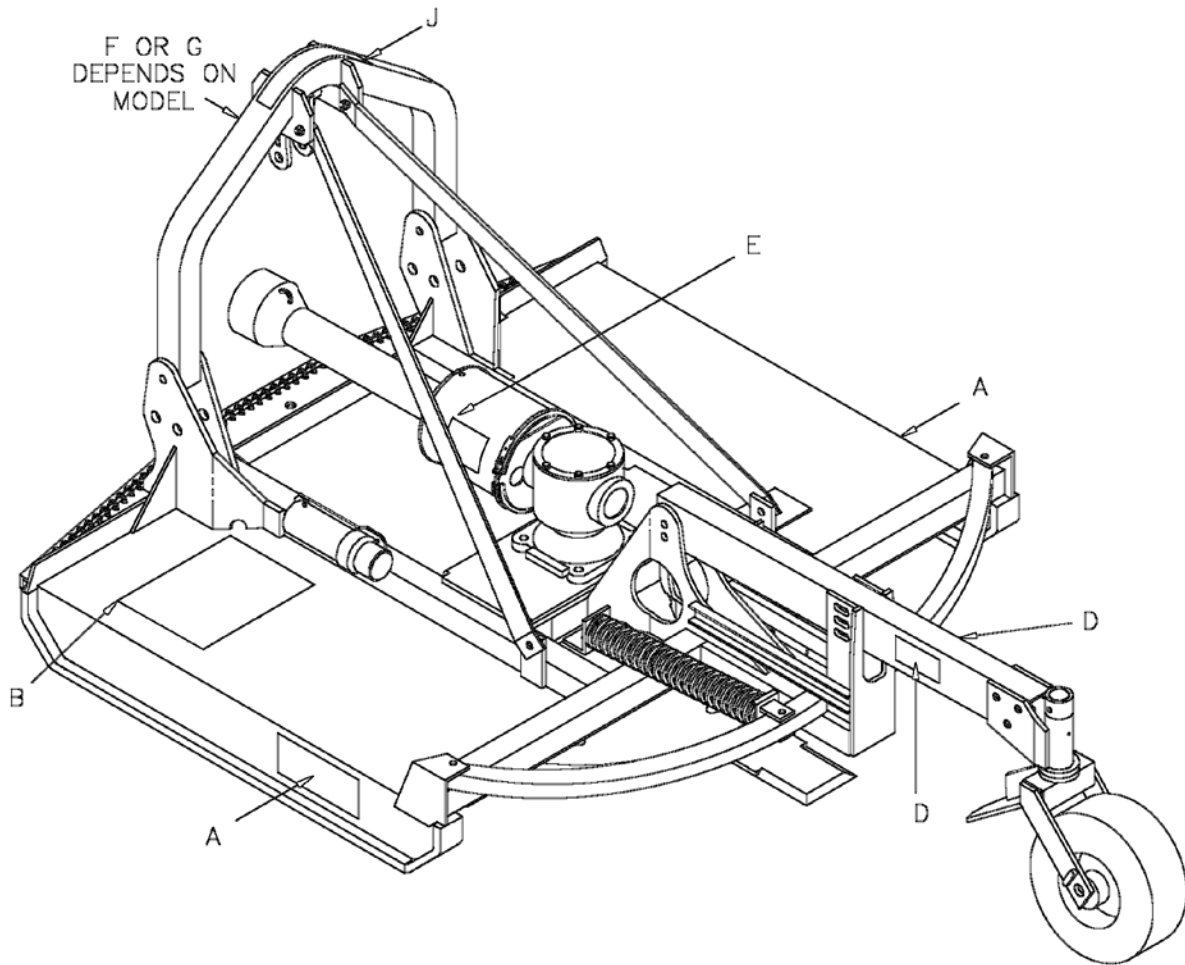

Ref. No.	Part No.	Description
A	SD-001A	Safety Decal: Thrown object hazard (2 req.)
B	SDL-020	Safety Decal: Lexan Combo
D	SD-005A	Safety Decal: Rotating blades (2 req.)
E	SD-006A	Safety Decal: Rotating driveline (2 req.)
F	SD-007A	Safety Decal: Operate at 540 RPM
G	SD-008A	Safety Decal: Operate at 1000 RPM.
J	SD-011A	Safety Decal: Missing deflector hazard

Equipment Safety

POTENTIAL DANGER AREAS OF ALL TREE CUTTERS

- A. EXPOSED ROTATING BLADES
- B. MATERIAL DISCHARGE
- C. ROTATING DRIVESHAFT
- D. PRESSURIZED HYDRAULICS
- E. FOLDING DECKS
- F. PINCH POINT
- G. HOT SURFACES

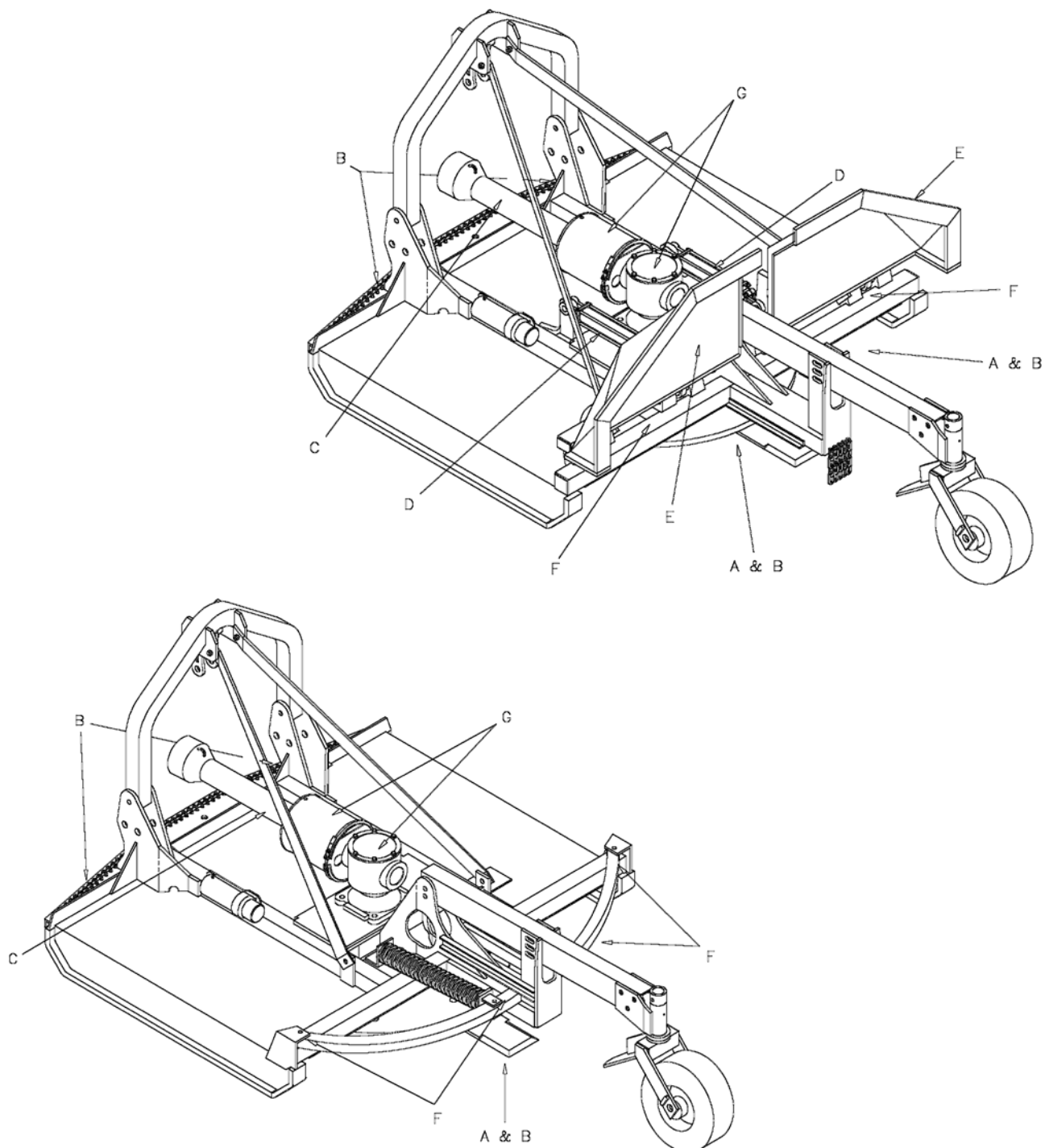

Equipment Safety

Warning

Transport with care.

Before transporting to a new location, make certain that the slow-moving vehicle (SMV) emblem is installed and is clearly visible. Use flashing lights and follow local traffic regulations.

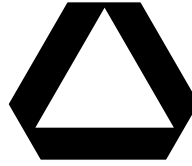

WARNING

Transport with care. Use slow-moving vehicle emblem and flashing light. Follow local traffic regulations.

Danger Protect bystanders, clear work area of debris.

Do not operate the cutter near people. Debris can be thrown hundreds of feet. Clear work area of foreign objects such as wire, glass, and other debris. Debris thrown by the cutter can cause serious injury or death.

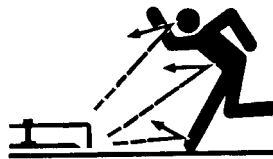

DANGER

Do not operate cutter near bystanders. Clear work area of debris before operating.

Warning Parking and dismounting.

The rotating parts of this cutter continue to rotate even after the PTO has been disengaged. The operator should remain seated until rotation has stopped. He should then set the brake, turn off the engine, and remove the key. See tractor manual for proper parking procedure.



WARNING

Wait for all rotation to stop before dismounting tractor.

Caution

Avoid fires.

Keep the machine clean of debris, trash, and any other flammable material.



CAUTION

Keep machine clean of debris. Flammable debris on machine poses fire hazard.

Warning

Fasten Seat Belt before starting tractor.

Always Wear Your Seat Belt.

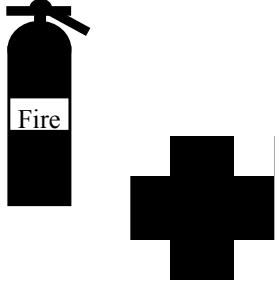

Equipment Safety

	⚠️ WARNING
	<p>Prepare for emergencies. Keep fire extinguisher and first aid kit available.</p>

⚠️ Warning

Prepare for emergencies.

Keep fire extinguisher and first aid kit available. Inspect fire extinguisher and check for charge daily. Check first aid kit for expired contents and keep stocked.

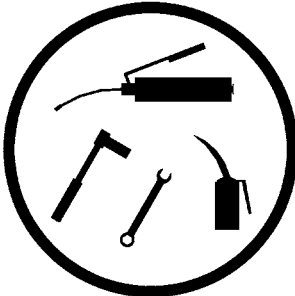
	⚠️ WARNING
	<p>Check equipment before operation. Tighten all nuts and bolts.</p>

⚠️ Warning

Check equipment before operating.

Tighten all nuts and bolts before operating. Make certain that equipment is lowered to ground before attempting to make adjustments or perform maintenance. Replace or repair any safety device, bolts, etc., if damaged or worn.

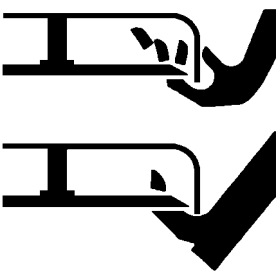
	⚠️ DANGER
	<p>Rotating blades. Keep hands and feet from under cutter deck.</p>

⚠️ Danger

Stay clear of rotating blades.

The cutter is designed to cut grass and brush up to 6" in diameter on 5' models or 8" in diameter on 6' models. **Keep hands and feet from under cutter deck!**

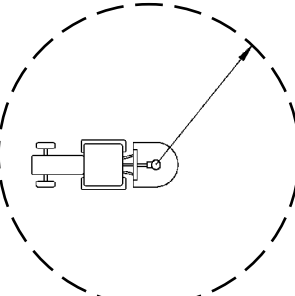
	⚠️ DANGER
	<p>Maintain safety distance of at least 300 ft. Failure to do so may cause serious injury or death.</p>

⚠️ Danger

Maintain safety distance.

The cutter creates a serious discharge hazard. Always maintain a safety distance of at least 300 ft. **Never operate cutter with bystanders present!**

Equipment Safety

Warning! Wear protective clothing.

Wear close-fitting clothing and other protective devices appropriate for the job.

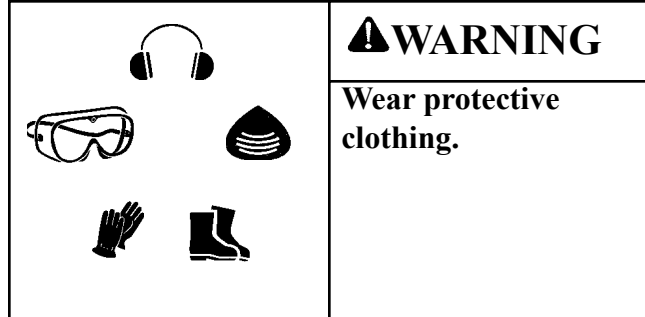

Warning! Roll-over protection.

Do not operate the cutter on any tractor not equipped with a certified roll-over protective structure (ROPS).

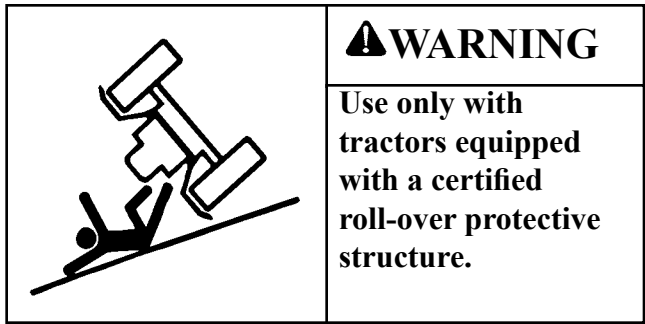

Warning! Slopes and rough terrain.

When operating on slopes or rough terrain, decrease travel speed. Do not operate in an area where the tractor could roll over. **Be sure to fasten safety belt when operating tractor!**

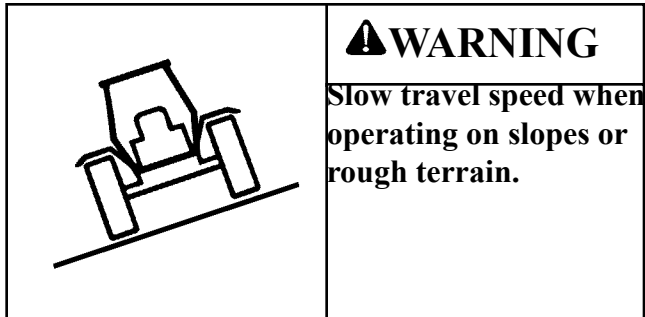

Danger! Tighten blade bolts.

Blade bolts will stretch with use and must be tightened. Follow maintenance instructions in this manual (see page 31). **If the cutter is operated with loose blade bolts, blades and blade carrier will be damaged. Operation with damaged blades and blade carrier will lead to blade ejection and will cause serious injury or death.**

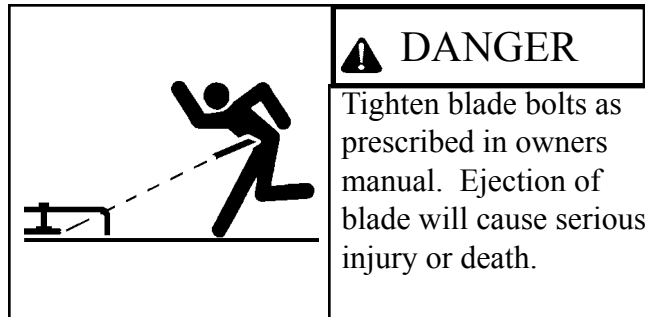

Equipment Safety



⚠️ DANGER
Riders can be injured or killed. Keep riders off machine.

⚠️ Danger! Keep riders off machine.
Riders can be seriously injured or killed by entanglement or by falling.



⚠️ DANGER
Stay clear of rotating drivelines. Keep driveline shields in place.

⚠️ Danger! Stay clear of rotating drivelines.
Entanglement in driveline can cause serious injury or death. Keep driveline shields in place at all times during operation. Driveline must turn freely inside shields. Driveline shields must be chained to prevent rotation.

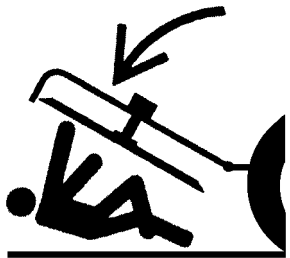

⚠️ WARNING
Exercise caution while working under cutter deck. Failure to heed warnings may lead to serious injury or death.

⚠️ Warning! Hazardous service conditions.
While working under the cutter deck, be aware of safety hazards. Follow safety precautions specified in this manual (see page 32). Failure to exercise caution may lead to serious injury or death.

⚠️ WARNING



HIGH-PRESSURE FLUID HAZARD
To prevent serious injury or death:

- Relieve pressure on system before repairing or adjusting or disconnecting.
- Wear proper hand and eye protection when searching for leaks. Use wood or cardboard instead of hands.
- Keep all components in good repair.

237-0002

⚠️ Warning!
High Pressure Fluid Hazard.

Folding Back Models are equipped with hydraulic hoses and cylinders, use all safety precautions when working around hydraulic components.

Assembly

Standard Assembly

1. Install tailwheel stem, Item D next page, into fork holder tube, Item E next page, placing collar, Item F next page, over stem and inserting roll key, Item G next page, through collar and stem.
2. Raise A-frame from its shipping position to its operational position (almost perpendicular to the cutter deck) . Install A-frame braces to the mounting brackets at the top of the A-frame with the provided bolts and tighten securely, Item H next page.
3. Open Deck - Bolt the rear end of the A-frame braces to the mounting brackets near the rear of the deck and tighten bolts securely. See Item A, next page.
- 3a. Folding Deck - Bolt the rear end of the braces to the inside of the outside hinge - see Item B, next page. Assemble hydraulic hoses BEFORE the installation of drive shaft. See diagram 20-1, page 20.
4. Separate the male and female halves of the drive shaft. Apply heavy grease to the telescoping portion of the male drive shaft. Recouple the drive shaft.
5. Locate the slip clutch bell shield, bolts, and mounting plate attached to the machine. Position bell shield on mounting plate and install the mounting bolts, flat washers, and lock washers to the gearbox face plate.



WARNING! The driveline shield and bell shield must be kept in good operating condition.

Failure to maintain safety shields can result in injury and death.

6. Remove the two-piece bridge clamp from the clutch hub assembly. Slide the hub onto the input shaft of the gearbox. Align the groove of the input shaft with the bolt grooves on the hub. Reinstall the two-piece bridge clamp with the two bolts provided and tighten securely. Retorque lock bolts every hour for the first eight hours of use. **Failure to do so will result in decreased life of the clutch hub and gearbox shaft splines.**
7. Attach bell shield to mounting plate with bolts.
8. Check the drive shaft for proper length:
 - a. Hitch the cutter to the tractor, please refer to page 21 “Attach equipment to tractor”..
 - b. Lift the cutter to the tractor’s maximum lift position.
 - c. Measure the distance from the PTO of the tractor to the input shaft of the cutter’s gearbox.
 - d. Push both halves of the drive shaft together fully. Measure the overall length.
 - e. If the length of the compressed drive shaft is greater than the length between the PTO and input shaft, then the drive shaft must be shortened.
Please NOTE: Equal amounts must be removed from each section of the drive shaft.

Assembly

Standard Assembly (continued)

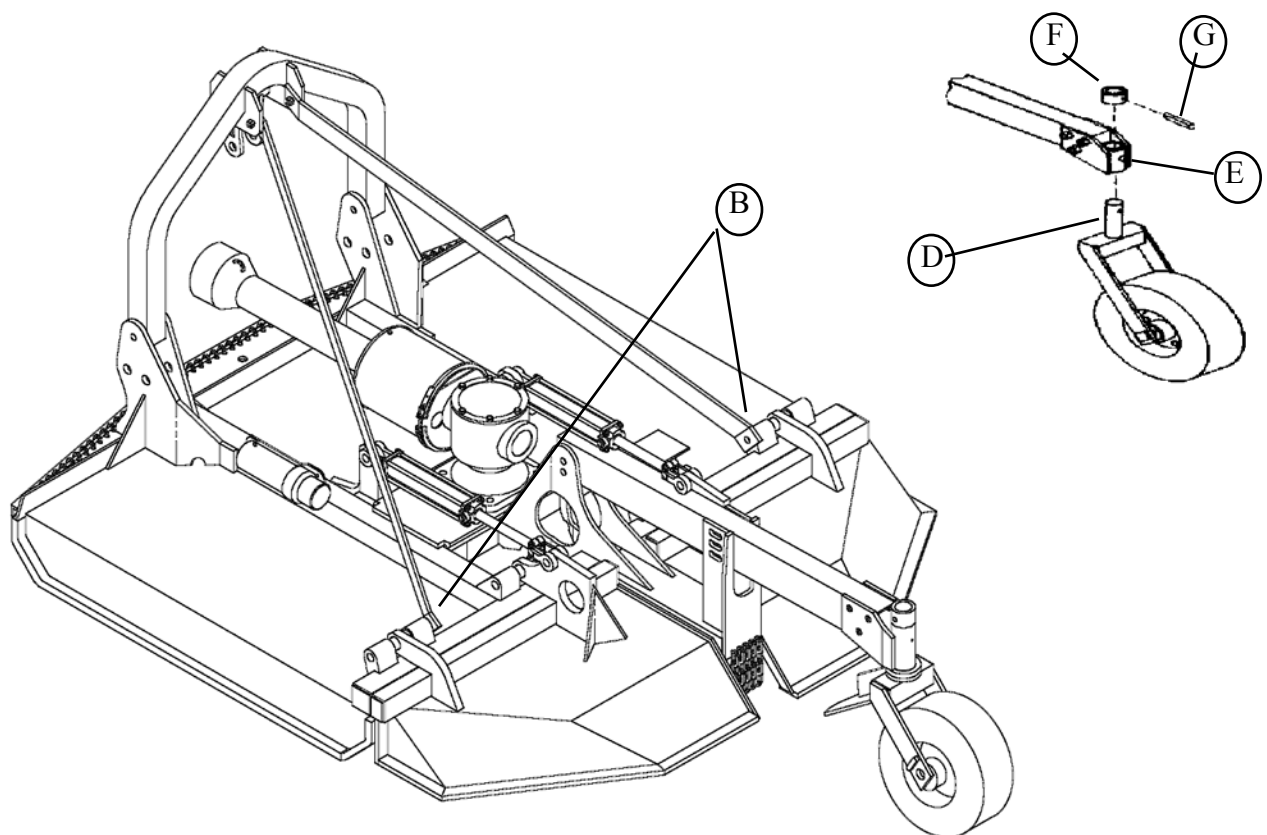
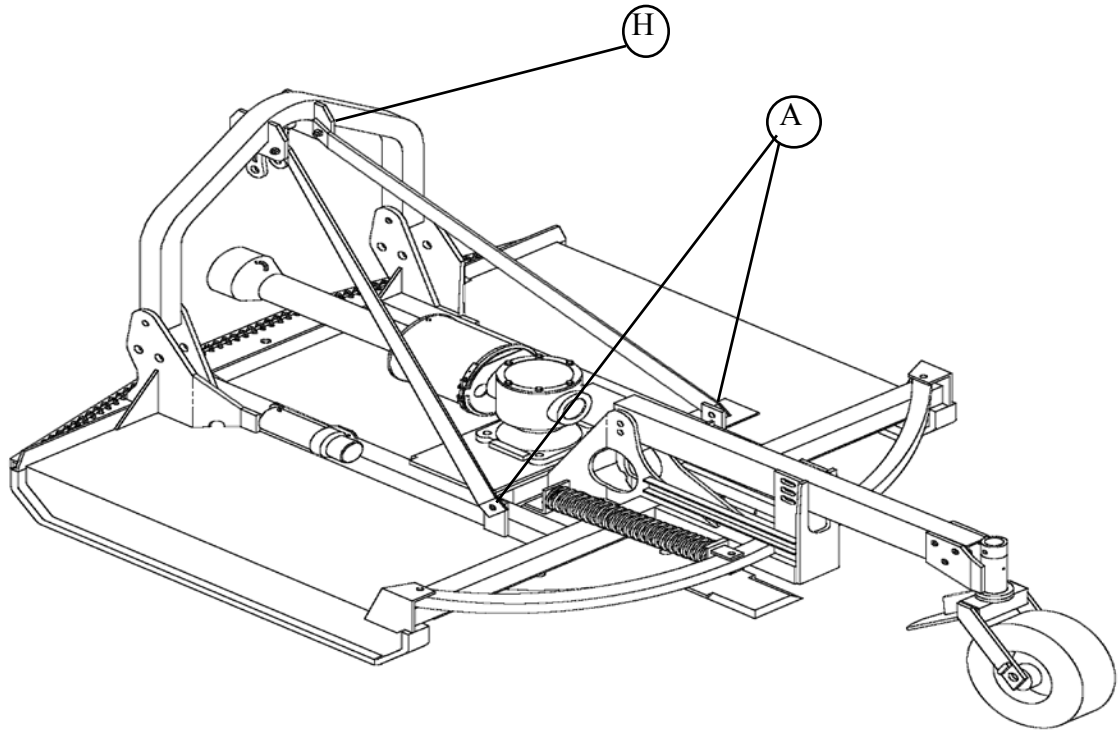

Assembly

Standard Assembly (continued)

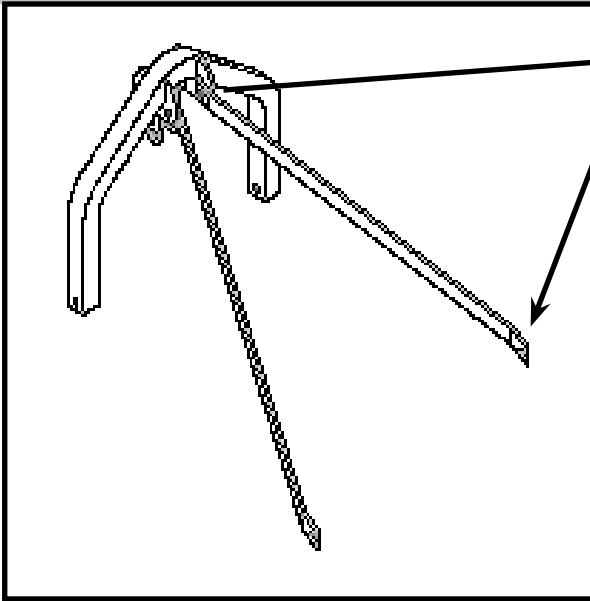

Attach A-Frame Braces to A-Frame and Deck with hardware provided.

20-1

FOLDING DECK MODELS HYDRAULIC HOSE ASSEMBLY INSTRUCTIONS

Step 1: Attach Item 6: Hydraulic Tees to the ports on the left cylinder (See Detail "A" Item 6.

Step 2: Attach hoses from tractor (Items 4 and 5), to the end of the tees closest to the tractor. Attach the straight end of the 36" hose to the rear (closest to tractor) of the front tee.

Step 3: Attach the 90 degree fitting to front port (closest to tractor) on the right cylinder (Item 1).

Step 4: Attach to straight end of the 24" hose to the rear port of the left cylinder and the 90 degree end to the rear port of the right cylinder.

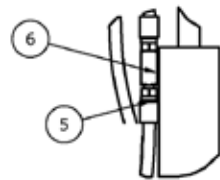

DETAIL A

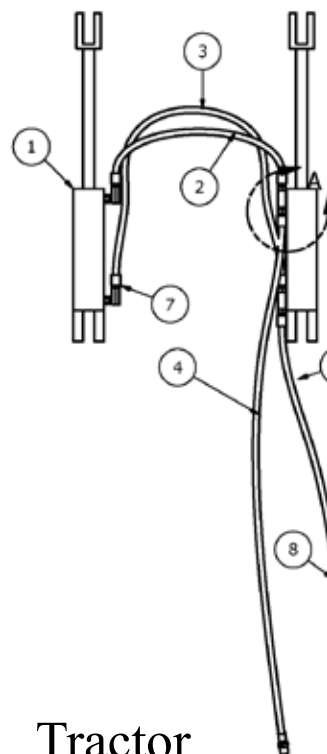

Note:

Route short hoses (Items 2 and 3) around gear box.

Item 4: Longest Hose Assembly To Rear Tee from Tractor.

Item 5: Shorter Hose Assembly to Front Tee from Tractor.

Route Hoses to Inside of A-Frame. Brace & Secure With Nylon Pull Ties

Tractor

Cutter Operation

Before hitching cutter to your tractor, make sure all safety devices are installed on both the cutter and the tractor.



Please follow all safety instructions and procedures.

Attach equipment to tractor.

Be sure the tractor is equipped with the correct category hitchpins, top link, a certified roll-over protection structure (ROPS), and an enclosed operator-protective cage to prevent hazards such as thrown, falling, or stationary objects from entering the protective cage.

Be extremely careful when positioning tractor to hitch to the equipment.



Caution! Never allow anyone between the tractor and the equipment during the hitching process.

Be certain that the cutter has been lubricated properly and check oil level in gear box prior to connecting driveline to tractor. Also, do not tighten the top link such that the flex-link toggle is fully extended toward the tractor. The flex-link should be in a relaxed position when on level ground. See diagram 21-1 Page 21,.

Attach the driveline to the tractor. **When attaching driveline to PTO shaft, be certain that the quick-disconnect pin is properly seated.**



Warning! An improperly attached driveline will disconnect and may cause personal injury or property damage.

21-1: Relaxed Top Link Position

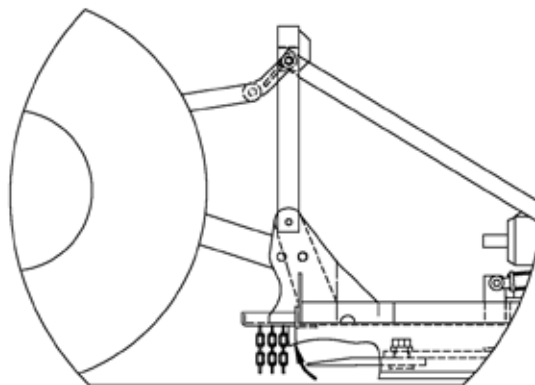

Adjust cutting height.



Warning! Be certain that tractor engine is stopped, key is removed, and all rotation of the cutter has ceased before making adjustments.



Caution! Avoid very low cutting heights. Striking the ground with blades causes a damaging shock that can damage both the cutter and the tractor.

Using the tail wheel adjustment, Item A below, and the tractor's lift arms, set the cutter to the desired height; the cutter is designed to operate with a cutting height range between 2" and 12". Note that, **on level ground, the front of the cutter should be 1" below the rear** . Set the tractor's lift stop at the required position to maintain a uniform cut.

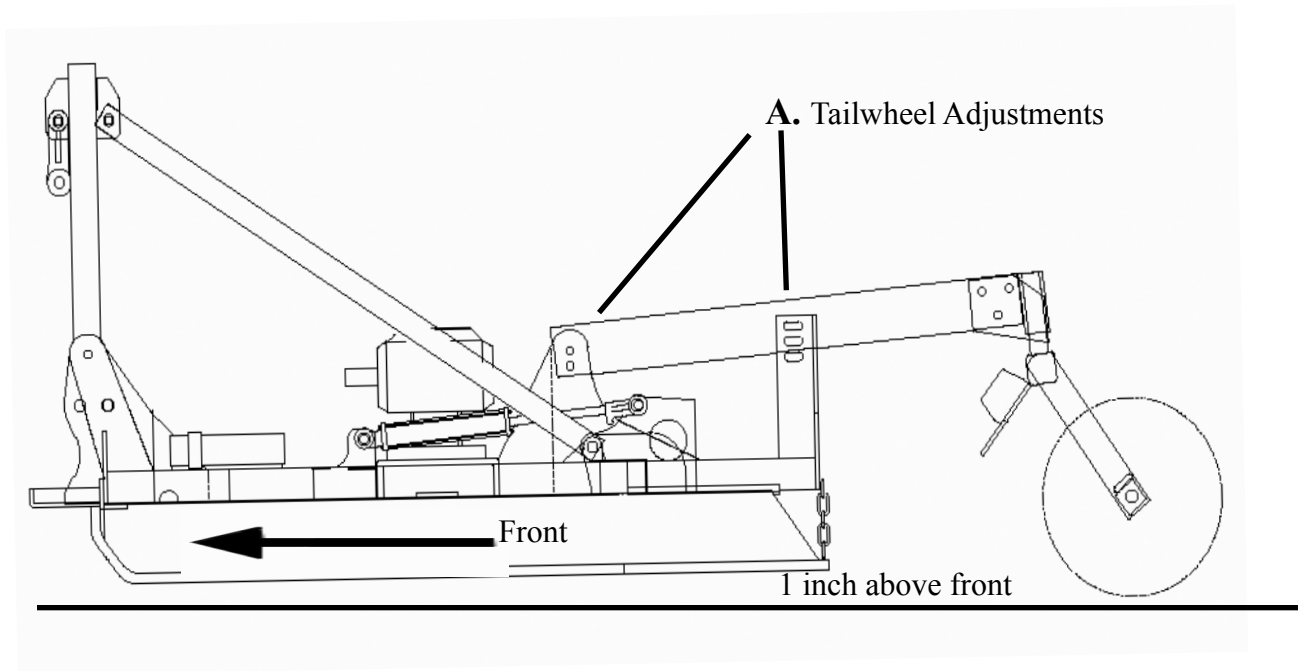

Starting Cutter

Power for operating the cutter is supplied from the tractor PTO. Refer to your tractor manual for instructions on engaging and disengaging the PTO.



Warning! Do not operate this cutter unless the tractor has a live, or independent, PTO. The momentum created by the blade carrier can push the tractor forward unexpectedly.



Warning! Operate cutter only with the specified PTO RPM.

Operating speed

Proper ground speed for equipment will depend upon the height, density, and type of the material to be cut. Regardless of chosen ground speed, always operate the PTO at the RPM rating of the gearbox, i.e. 540 RPM or 1,000 RPM (this number should be stamped on the back of the gearbox housing or on the A-Frame decal). Consult the tractor owner's manual to determine the engine RPM to achieve the required PTO RPM. Engine RPM

should not drop more than 300 RPM when cutting, if this happens chose a lower gear until the specified engine RPM is maintained. Dull blades will also require more power and result in lower ground speeds, always be sure blades are sharp.

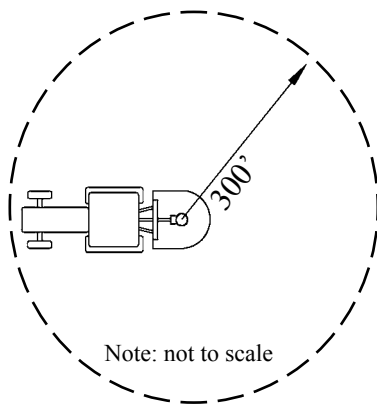

General Operation



Warning! The cutter creates a very serious discharge hazard. Maintain a safe distance from nearby persons and property. **Do not operate when bystanders are present.**



Warning! Avoid personal injury. Remove all rocks and other debris from work area before cutting.

Observe the following guidelines when operating the cutter:

- Never lower the cutter onto material.
- Avoid tight turns near trees or stationary objects. The deck may be damaged by side impact.
- When backing into large material, it is necessary to lift the cutter deck a small amount to remove the slack from the top flex link, to maintain a level blade path over the ground.

Remember: The safe operation of this equipment is the responsibility of the operator. The operator should be familiar with both the tractor and the equipment. The operator must read and understand all applicable operator manuals and follow all safety practices.

Cutter Operation

Using Choke Chains (Optional) - Not a factory supplied option.

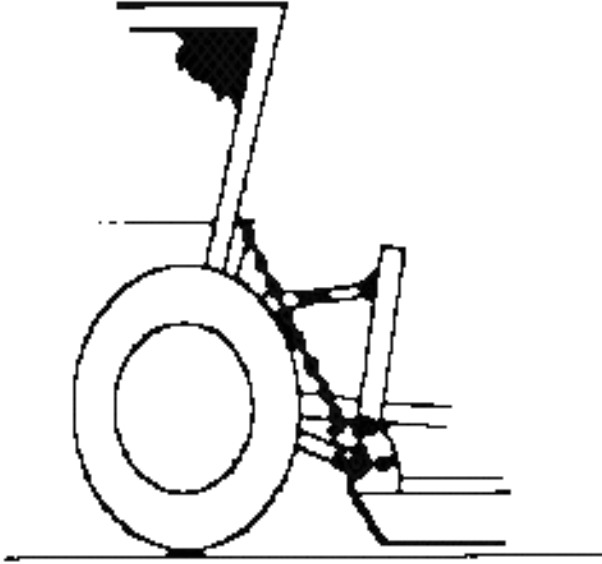

Choke chains are lengths of chain that attach from the tractor ROPS to the lift pins of the cutter unit. The chains are intended to hold the weight of the unit, insuring that the front of the cutter remains at a fixed altitude above the ground and removing the weight of the unit from the tractor's lift arms.

Choke chains attach to the outside of the cutter unit's lift pins, after the tractor's lift arms have been properly attached to the unit. The chains' hitch are then secured in place by the existing spring-clip pins in the unit's lift pins.

The chain system consists of two lengths of suitable chain, each with one end terminating in a hitch plate. A bracket attached to each side of the tractor's ROPS holds the other ends of the choke chains taut in slots milled to the width of a chain link. Choke chain length is adjustable by choosing which chain link is inserted into the retention slots of the ROPS brackets; fine-tuning of the chain lengths may be performed by twisting the chains before securing the chains into their retention slots on the ROPS brackets.

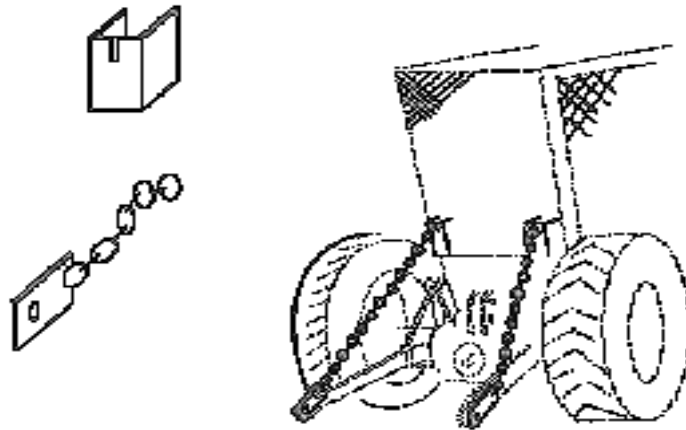

Cutter Operation

Before engaging your PTO, lift the cutter about one foot above the ground to ensure the blades are free to rotate. As you engage your PTO, your tractor engine may try to stall or lug down. If this happens, ease or bump your PTO lever in and out of gear quickly. This will give the blades time to start turning without slipping the clutch in your tractor. Continue to quickly engage and disengage your PTO lever, until the Tree Cutter blades gain speed to match the speed of your tractor engine. This procedure will greatly increase the life of your tractor's internal clutch pack. Repeat this each time you start up your Tree Cutter.

After your Tree Cutter has reached operating speed you may notice a small amount of vibration, this is normal.

!Notice: If there is enough vibration to shake the A-Frame of the unit in a violent manner, the unit should be shut down. Refer to the troubleshooting guide of this manual or call the factory for help at 1.800.633.8909.

Your Brown Tree Cutter has been designed to cut anything that your properly rated tractor can drive over (grass, brush, small trees up to about 3 inches in diameter). For larger material, up to 6 inch diameter material on the 145 horsepower model and 8 inch diameter material on the 165/240 horsepower models, back into the material (on folding deck models the hydraulic deck should be opened before backing into the material). Any trees larger than this are too large for the Tree Cutter and should not be cut with this machine.



Warning! Trees can fall in any direction, it is the operator's responsibility to be sure the area is safe and clear.

Refer to the warranty section of this manual for the warranty statement on use of the Tree Cutter.

When the Tree Cutter is cutting large diameter trees it is very important to keep the cutter deck level. If the cutter deck is not level, its ability to cut is greatly reduced. There is a tremendous amount of pressure applied to the blades. The blades are making contact with the tree on an elevated angle. The blades must be level in relationship to the ground. If not level the pressure can cause the blades to bend or break, possibly causing serious injury or death. (SEE DRAWING BELOW)

NOTICE: The folding decks should only be opened when a 300 ft. area around the unit is clear of all discharge concerns i.e. cars, house, crew personnel and bystanders.

CORRECT

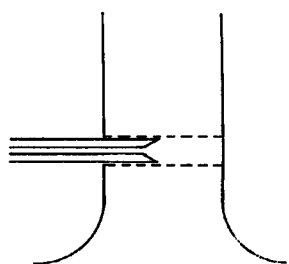

WRONG

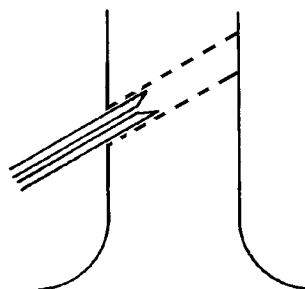

DANGER: Extreme pressure is being applied on the blades. This pressure can cause the blades to bend or break.

Operating Instructions

The Tree Cutter's gear box, regardless of the tractor's PTO of 540 or 1000 RPM is geared to produce 810 RPM to the blade bar of the Tree Cutter. Multiply the 810 RPM times the 4 blades on the blade bar, this will give you 3,240 blade strikes per minute. Divide that by 60 seconds per minute and your total number of blade strikes per second is 54. The blade tip speed of a 6 foot Tree Cutter is 173.41 miles per hour. All of this was said to make one point: The Brown Tree Cutter will cut a large diameter tree off its stump before you know what happened.

The tractor ground speed backing into large diameter material is very important. If you cut a tree too fast, it will cause the trunk of the tree to kick straight back allowing the top of the tree to fall back toward the tractor. The proper ground speed for backing into the material is based on the size of the material. The slower the unit is backed into large diameter trees the more time the pressure bar and blades have to do their job. On folding deck models, with the folding deck open, the deck itself will act as a shield to help shed the tree off to the side of the cutter and tractor.



Caution! During the time the blades are making contact with any material, DO NOT move the tractor lift setting. The movement of the cutter deck will again increase the pressure on the blades. This pressure can and will cause blades to bend or break.

Special attention should be given when the unit is being turned in a tight area. The tail wheel assembly projects several feet behind the unit. In a tight turn it is possible to hit the tail wheel arm on a nearby object or tree. The tail wheel assembly is not designed for side forces. These forces can cause the assembly to fail.



Caution! After the first hour of operation, the Tree Cutter must be shut down for maintenance and inspection. During this time ALL bolts must be checked for proper torque. If any bolts are found to be loose, they must be tightened. Also check for wire or vines caught around to output shaft of the gear box or the tail wheel axle.



CAUTION - NEVER OPERATE THIS UNIT WITHOUT PROPER SAFETY DEVICES IN PLACE - SERIOUS INJURY OR DEATH CAN OCCUR.



WARNING:
A safe distance from discharge hazards must be kept at all times during the operation of your Tree Cutter, regardless of the model or design. This distance is to protect persons and property from death, injury, or damage.

It is the sole responsibility of the operator to insure a safe operating area.

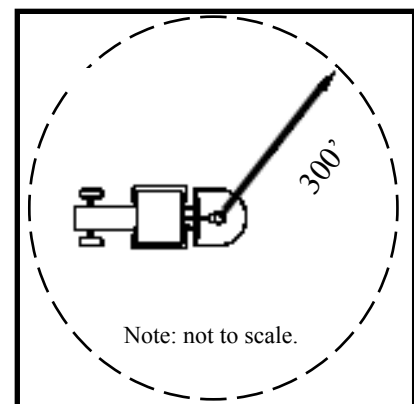

OPERATING INSTRUCTIONS

PLEASE READ AND UNDERSTAND
IF YOU DO NOT UNDERSTAND ANY POINT STATED BELOW
YOU MUST CALL THE FACTORY FOR ASSISTANCE
1-800-633-8909

USE ONLY GENUINE BROWN REPLACEMENT PARTS.

USE OF AFTERMARKET PARTS OR COMPONENTS WILL VOID ANY WARRANTY CONSIDERATION

BLADES This machine was designed to operate **ONLY** with sharp blades. Dull blades will cause multiple types of problems that are **NOT** covered under warranty:

- a. Slip clutch failure
- b. Extreme wear on blade bolts
- c. Blade bar fatigue and cracking or total failure
- d. Blade fatigue and cracking or total failure
- e. Deck fatigue and cracking
- f. Increased amount of discharge or debris
- g. Poor cut – increased amount of uncut material
- h. Blades must be freely pivoting during operation

BLADE BOLTS Blade bolts **MUST** be kept tight and checked twice daily during operation. Every hour for the first 8 hours of use.

- a. Brown's blade bolts are designed for the extreme conditions and should not be substituted for any reason
- b. 6' Brown Tree Cutter blade bolts are **RIGHT** hand thread
5' Brown Tree Cutter blade bolts are **RIGHT** hand thread
- c. Bolts and lock nuts are matched as pairs or sets – do not mix
- d. See maintenance section for proper torque specifications
- e. When replacing or repairing blades copper anti-seize should be applied to the blade bolts. All new blade bolts are being shipped with packets of anti-seize.

BLADE BAR Proper maintenance of blade bar will insure long life.

- a. Loose blade bolts will impact the bottom of the blade bar, causing the blades to lock into a fixed position.
- b. Loose bolts will cause the elongation of bolt holes
- c. Dull blades will cause the blade bar to crack and fail
- d. Blade bar nut must be checked and kept tight at all times
- e. Loose blade bar can cause output shaft failure, blades striking the bottom of the deck, blade breakage and blade bar cracking
- f. Bar **MUST** be inspected daily for cracking or fatigue
- g. Use anti-seize when installing/reinstalling blade bar.

Continued-Next Page

OPERATING INSTRUCTIONS con't

CLUTCH

CLUTCH WEAR OR FAILURE is not covered under warranty.
Improper operation of the unit will cause the clutch to slip

- a. When the clutch slips the operator must lift the cutter off the obstruction immediately
- b. Clutch must be allowed to cool after slippage
- c. Excessive ground speed or dull blades will overload the clutch capacity
- d. Timely replacement of worn clutch discs
- e. Proper reassembly of slip clutch



WARNING: NEVER ALLOW BLADES TO COME INTO CONTACT WITH ROCKS OR STUMPS.

The blades will be forced to glance over the top of the obstruction, causing a tremendous amount of upwards pressure on the blades, blade bar and output shaft. This pressure can and will cause fatigue, cracking and possible breakage of the components. NEVER lower blades down onto material, the same pressures will be applied to the components causing failure.

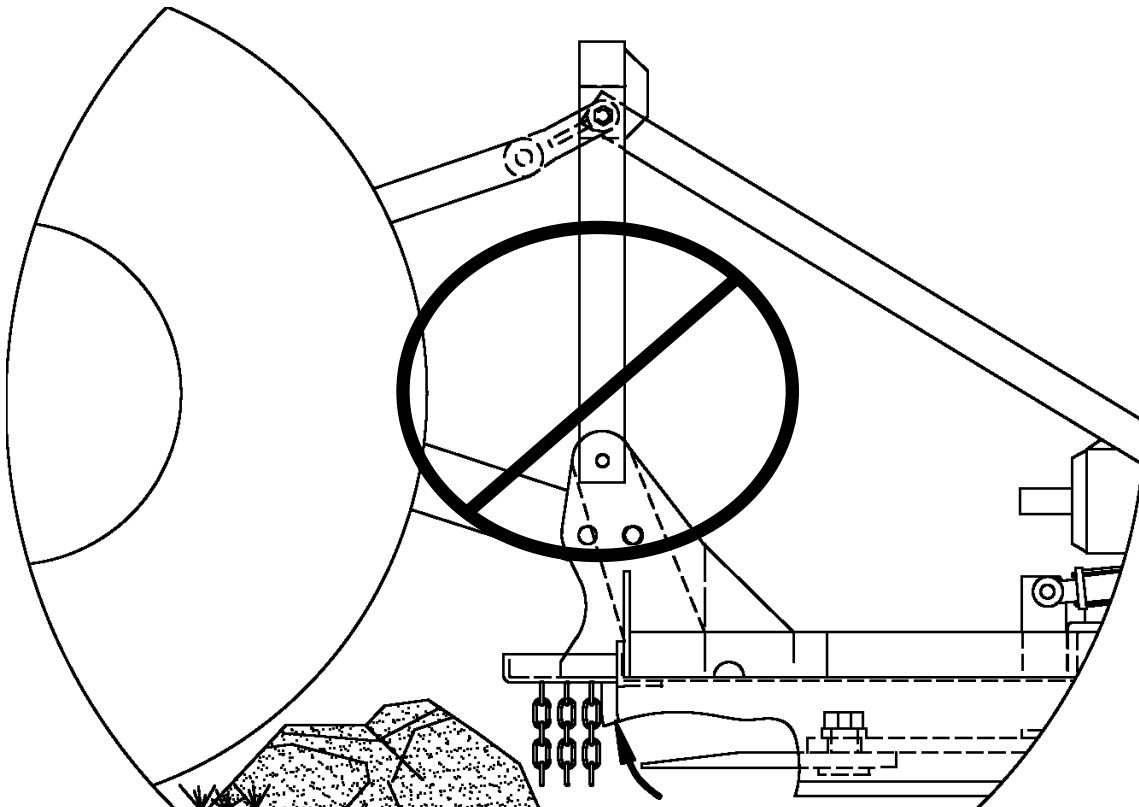

WARNING! NEVER DO THIS!

THE TEN COMMANDMENTS OF OPERATION

1. **ALWAYS** - Read and understanding the owners manual before operating this or any other equipment.
2. **ALWAYS** – Attach this equipment to a tractor that has suitable safety equipment properly installed.
3. **ALWAYS** – Operate this equipment with all safety devices properly installed on this equipment.
4. **ALWAYS** – Inspect, walk, flag or remove all foreign material from job site before starting the cutting process.
5. **NEVER** – Allow any riders or bystanders within 300 feet of this unit during operation.
6. **ALWAYS** – Check all bolts, fasteners, fittings and oil levels before beginning operations each day. Make sure blades are free swinging.
7. **NEVER** – Allow blades to make contact with rocks or stumps – unit was not designed for this type of operation.
8. **NEVER** – Allow an untrained operator to operate this equipment.
9. **ALWAYS** – Install only genuine Brown replacement parts.
10. **ALWAYS** – Remain on tractor seat until blades have stopped turning and all tractor shut down procedures have been completed.

THESE ARE ONLY A FEW OF THE SAFETY PROCEDURES THAT MUST BE FOLLOWED TO INSURE THE SAFE OPERATION OF THIS EQUIPMENT – MANY OTHER SAFETY RELATED POINTS ARE STATED THROUGHOUT THIS MANUAL



WARNING: FAILURE TO FOLLOW THE TEN COMMANDMENTS CAN AND WILL CAUSE SERIOUS INJURY OR DEATH

IF YOU HAVE ANY SAFETY, MAINTENANCE OR OPERATIONAL QUESTIONS – PLEASE CALL THE FACTORY BEFORE USING THIS EQUIPMENT – 1-800-633-8909

Maintenance

Daily Maintenance

1. Repeat all steps listed under the “Initial Maintenance” section (next page) on a daily basis after the initial maintenance has been performed.
2. Lubricate the driveshaft tubes, U-joint, and safety shields.
3. Lubricate the tailwheel hub and fork holder.
4. Check and maintain the proper amount of lubricant in the gearbox, oil weight is 85-140, our part number is T5-LUBE (see page 35).
5. Check blades; sharpen or replace as necessary. **When sharpening blades, only sharpen the beveled edge. Also, be certain that paired blades weigh within one tenth of a pound of each other. When replacing blades, replace both blades of the pair.**

⚠ Warning! If the blades must be sharpened, follow the proper safety procedures listed on page 32 of this manual for working under the cutter deck.

Tightening Blade Bolts

Before starting a cutter, or after blades have been removed for any reason, tighten blade bolts using the following procedures. **Repeat hourly inspections each time the blades are removed/replaced.**

⚠ Warning! Follow safety guidelines listed on page 32 of this manual when working under cutter deck. Do not rely on the tractor’s lift arms to support the cutter while performing maintenance.

1. Disengage PTO; be certain that all rotation has stopped.
2. Lift cutter high enough to place suitable supports under the cutter deck.
3. Turn tractor engine off; remove key; lock transmission and brakes; chock rear wheels.
4. Disconnect driveline.
5. On 145 HP Models, Use a pipe wrench to hold the blade bolt head; torque blade bolt nut with an 1 13/16” socket, part number TC2-006S, to approximately 900 to 1100 ft./lbs.
- 5a. On 165/240 HP Models, Use a pipe wrench to hold the blade bolt head; torque the blade bolt nut with a 2 5/8” socket, part number T5-004BS, to approximately 1200 to 1500 ft./lbs.
6. If your blade is NOT free swinging after tightening blade bolts install a shim on shoulder of blade bolt, shims are listed on pages 52 and 53, the shims depend on model. Do NOT operate a unit with blades that are not free swinging.

Maintenance

Safety When Working Under Cutter Deck

Never work under the cutter deck until:

- the cutter is sufficiently braced and supported
- the tractor engine is off, brake is set, and key is removed
- PTO has been disengaged
- driveline is disconnected
- rear tractor tires have been secured with tire chocks
- the cutter is cooled



Warning! Failure to follow these safety guidelines can result in serious injury or death.

Initial Maintenance



Warning! These maintenance practices must be followed every hour for the first eight hours of operation; the practices must also be performed every hour for the first eight hours following the removal/replacement of any of the components named in this section. Check daily thereafter.

1. Tighten the bolts holding the slip clutch to the input shaft of the gear box.

Caution! Failure to tighten the keeper bolts will shorten the life of the slip clutch hub.

2. Check for debris deposited between the blade bar and the blades. Debris found jamming or locking the blades must be removed to insure that the blade may pivot freely on the blade bolt.



Warning! Failure to maintain freely pivoting blades will cause severe vibration or blade breakage which can result in injury or death.

3. Tighten blade bolts, see page 31 for blade bolt tightening instructions, and for blade bar nut tightening instructions, see page 41.



Warning! Failure to tighten blade bolts and blade bar nut can cause blade bolts, blades, or output shafts to break, which can result in injury or death.

4. Check and remove any debris deposited around the output shaft.
5. Tighten gearbox mounting bolts.

Caution! Failure to keep the gearbox bolts tightened can cause the blades to strike the bottom of the cutter deck, break the output shaft of the gearbox, or break the gearbox housing. (Continued on Page 34)

Notes

Maintenance

! If blade bolts are allowed to run loose, the obvious danger is for the bolt to come completely loose, allowing the blade, bolt, and nut to be ejected from the cutter.

Tightening Blade Bolts (*continued*)

! The second danger is that when the bolt is not sufficiently tight, the blade is allowed excess vertical movement when it strikes an object, be it something it will cut or something into which it should not come in contact. In this situation, the blade is being hammered against the blade carrier and flexed, or bent, up around the edge of the blade carrier at least twelve (12) times per second, generally fifteen (15) times per second. This situation will cause the blade to break from fatigue and to be ejected from the cutter.

! The third danger is that, while the second situation is occurring, the blade bolt is also hammering the underside of the blade carrier; the shoulder of the blade bolt beats an indentation around the blade bolt hole into which the bolt shoulder will fit.

When this damage occurs, the blade bolt will pull up into the indentation when the bolt is tightened, causing the blade to jam so that it can no longer pivot on the blade bolt. A jammed blade will break either from fatigue or from catastrophic occurrence and will allow the blade to be ejected. A blade carrier damaged in this manner must be taken out of service immediately. Repair the blade carrier (contact Brown Mfg. Corp. for instructions) and replace the blades and blade bolts before returning the machine to service.

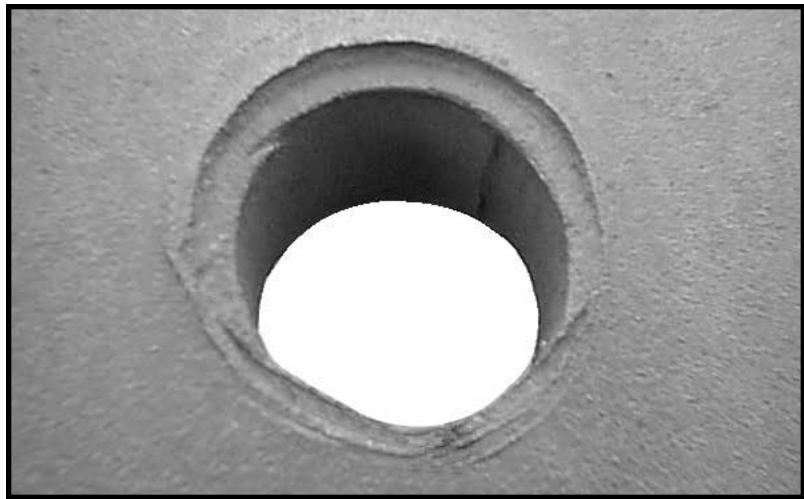

! All three of the described occurrences will cause the blades to break and be ejected. An ejected blade can and will cause serious injury or death.

**REMEMBER: Blades must pivot freely and blade bolts must be tight!
Shims are available if your blades bind when bolts are tight.**

Maintenance

Sharpening Blades

Blade sharpening procedure:

The Tree Cutter blades are manufactured from Ultra-Kor™ alloy, a space age material. When sharpening this blade material using a side grinder, use extreme caution not to over heat the material. Allowing the grinder to stop or rest in one spot will cause the material to turn “blue”. Avoid over heating by keeping the grinder moving at all times. Remember that the first 1” to 1 1/2” of the blade and the blade tip is where all of the cutting action takes place. This is point of contact and the blade bevel must be maintained and kept sharp. If you have the skill to sharpen the blades with a torch, less heat will be transmitted into the material and will have longer blade life if sharpened in this manner. Always remove equal amount of blade material from the paired blades. Blades must be kept within 1/10 of a pound of each other. Always keep blades in the same pairs, as removed from the cutter.

NOTE: Failure to keep the blades sharp will cause multiple problems, including

1. Slip clutch failure.
2. Extreme blade bolt wear
3. Blade bar fatigue, cracking and total failure
4. Blade fatigue, cracking and total failure
5. Deck fatigue and cracking
6. Increased amount of discharge or debris
7. Poor cut – increased amount of uncut material

Food for Thought: If your blade was an axe head, would you try to cut a tree with it?

Proper Gearbox Lubrication

With the cutter sitting level, find and remove the combination vent plug/dip stick from the top of the gearbox. Wipe the dip stick clean and reinsert. Then remove. Oil should touch the dip stick. If not, add oil until it is no higher than 1/2” to 1” on the dip stick. Excess oil in the gearbox will be exhausted through the vent plug/dip stick. Proper replacement oil is 85-140 weight gear oil, our part number is T5-LUBE. **Make certain the plug is replaced and tightened securely before operating.**

Adjusting the Torque Setting on the Slip Clutch

The slip clutch settings are described on the following two pages and page 58. Contact Brown Manufacturing Corporation at 800.633.8909 for assistance with clutch torque problems.

REASONS SLIP CLUTCHES FAIL

* DULL BLADES*

When the blades become dull, the cutting or chipping effect is lost; (dull blades become hammers and will not cut). The dull blades require more torque to hammer into and through the material. The Tree Cutter is not designed to hammer through material. This hammering action will destroy the machine and slip clutch from increased shock load and increased torque required from dull blades. **NEVER** operate the unit with dull or damaged blades.

* GROUND SPEED*

Excessive ground speed increases the torque load to the slip clutch. As more material is fed into the cutting chamber; more torque is required to pass through the slip clutch. NOTE: A good measure for proper ground speed is to watch the tractor tachometer, if the tractor engine loses speed (R.P.M. drop) reduce your ground speed to regain your engine speed. **NEVER** reduce your ground speed by the engine throttle; (select a lower gear to reduce ground speed).

* DECK ADJUSTMENT*

Improper deck adjustment or deck attitude will increase the torque load to the clutch. *See proper deck adjustment in this manual.* The front of the cutter deck should be adjusted 1 inch lower than the rear of the deck, this allows the material to be cut on the front side of the blade arc. If the deck were adjusted with the front higher than the rear, all the material will be cut twice. **NEVER** lower cutter deck down onto material. Keep cutter deck down on the ground at cutting height.

* ENGINE SPEED*

Your tractor engine is designed to operate at a continuous speed to produce a given P.T.O. speed (540 or 1000 R.P.M.). Failure to keep the tractor engine at the proper speed will cause the Tree Cutter to be under powered; thus increasing the torque load to the slip clutch. Refer to tractor owners manual for proper tachometer setting to deliver the proper P.T.O. speed to the cutter. **NEVER** operate your cutter at less than manufactures recommended engine speed for proper P.T.O. output speed. The Tree Cutter is designed to operate at a certain P.T.O. speed (NOT BOTH). Refer to model number or call Brown Mfg. Corp. if you have questions about your Tree Cutter design speed.

SLIP CLUTCH FAILURE IS NOT COVERED UNDER WARRANTY

**TORQUE SETTING PROCEDURE FOR SLIP
CLUTCH IS FOUND ON PAGE 58**

SLIP CLUTCH ASSEMBLY DIAGRAM

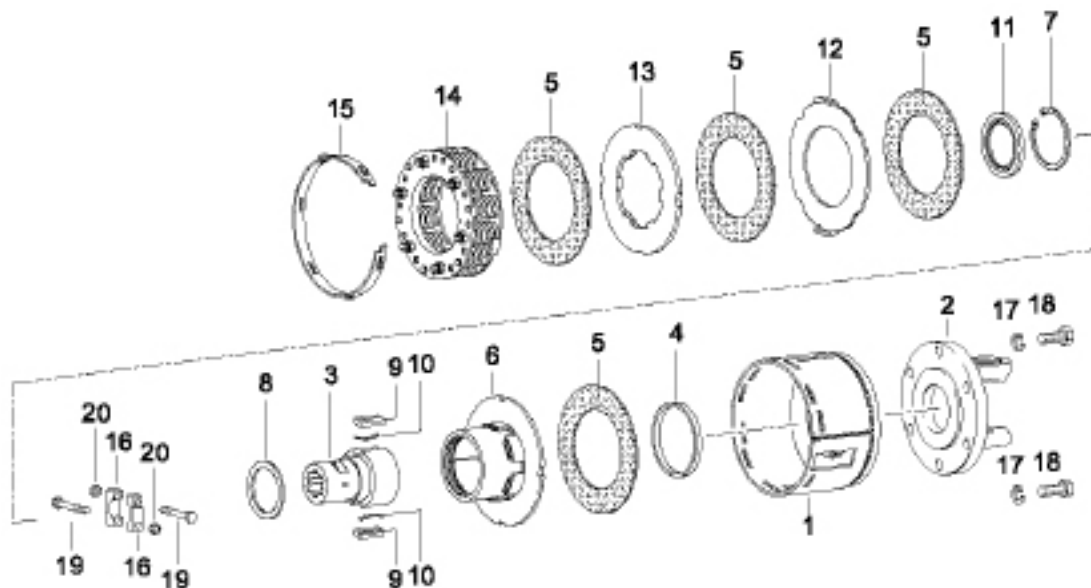

Ref. No.	Part No.	Qty.	Description
1	236-2099	1	Clutch Housing
2	236-2010	1	Yoke (Bolt On)
3	T5-W30	1	Hub, 1 3/4" x 6 Spline 540 RPM
	T5-W43	1	Hub, 1 3/4" x 20 Spline 1000 RPM
4	T5-W19	1	Centering Ring
5	T5-W20	4	Friction Lining
6	T5-W21	1	Drive Plate
7	T5-W22	1	Lock Ring
8	T5-W23	1	Supporting Ring
9	T5-W25	2	Key
10	T5-W24	2	Leaf Spring
11	T5-W32	1	Sealing Ring
12	T5-W26	1	Drive Plate (Outer)
13	T5-W27	1	Drive Plate (Inner)
14	T5-W49	1	Spring Pack
15	T5-W29	1	Setting Ring
16	T5-W33	2	Clamp Bridge
17	MLW12Z	6	Lock Washer M12
18	MCS12C30Z88	6	M12 x 1.75 x 30 x 8.8GR Bolt
19	T5-W35	2	Bolt M16 x 110mm for T5-W33
20	T5-W34	2	M16 Nut for T5-W33

BLADE INSTALLATION PROCEDURE

DO NOT RELY ON THE TRACTOR LIFT SYSTEM TO HOLD THE CUTTER UP DURING ANY MAINTENANCE PROCEDURE.

Blades are sold in pairs only, by weight - mount in pairs only!

Shut the unit down, see page 32 for “Safety When Working Under Cutter Deck”. Lift the cutter deck about one foot above the ground and place jack stands or blocks on each side of the cutter deck to support the weight of the cutter. Lower the deck to rest on the stands.

The Brown Tree Cutter uses a total of four cutting blades, all four blades are alike. It is necessary that the blades are installed in the correct sequence. When installing new blades, alternate the position of the cutting bevel, first one blade up, next blade bevel down. After all four blades are installed, bevel up blades will be directly across (180 degrees) the blade bar from each other.

Replacement blades are shipped in pairs by weight, keep blades in pairs - DO NOT MIX - mount pairs across the bar from each other.

All blades are mounted underneath the blade bar and the blade bolt is inserted from below with the nut on top of the blade bar.

NOTE: See blade bolt tightening procedure for additional information on blade bolt torque requirements. See Page 31 for tightening instructions.

NOTICE: IF FOR ANY REASON ONE BLADE MUST BE REPLACED, ITS OPPOSING BLADE MUST BE REPLACED AT THE SAME TIME TO INSURE PROPER BALANCE OF THE BLADE BAR. IMPROPER BALANCE OF THE BLADE BAR WILL CAUSE VIBRATION AND POSSIBLE COMPONENT FAILURE.

Diagram denotes proper blade placement.

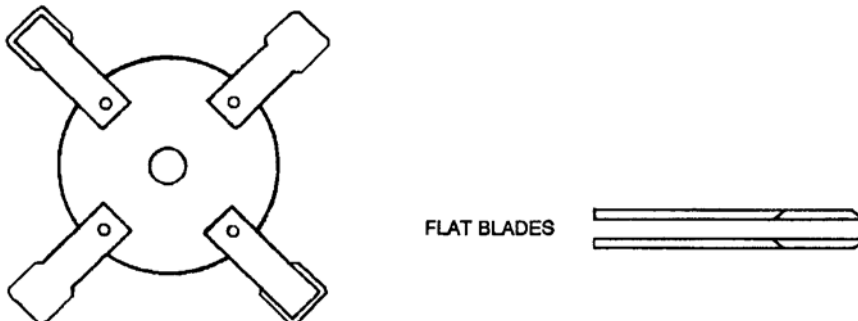

TREE CUTTER BLADE BAR REMOVAL PROCEDURE (ALL MODELS)

! CAUTION! KEEP FINGERS, HANDS, AND FEET OUT FROM UNDER THE CUTTER BAR AT ALL TIMES. FALLING BAR CAN CAUSE INJURY.

! CAUTION!

CUTTER DECK MUST BE SUPPORTED BY WHATEVER MEANS NECESSARY TO PREVENT DECK FROM FALLING WHILE IN THE VERTICAL POSITION. FAILURE TO SUPPORT THE DECK CAN AND WILL CAUSE DEATH OR SERIOUS INJURY.

Note: Cutter Deck MUST be stood vertically “on end”, past center “Refer to drawing below. This will prevent the bar from coming off the shaft during the removal process.

Step 1. With the cutter deck safely supported in a vertical position, remove the cotter pin and output nut, using a thin wall 2-9/16” - 6 point socket. This socket is available from Brown Mfg. part # T5-054AS.

Step 2. Tighten bar removal tool (part # T-2600-001) onto output shaft threads, tool must be tightened adequately to bottom out onto the bottom of the output shaft.

Step 3. Strike the head of the removal tool using a sledge hammer. The impact of this process will unlock the tapered root spline inside the blade bar hub. It may require multiple strikes to cause the spline to unlock. The sound will change to a “hollow” sound when the unlock occurs.

Use care while removing the tool from the shaft, make sure blade bar is supported and cannot slide off the shaft.

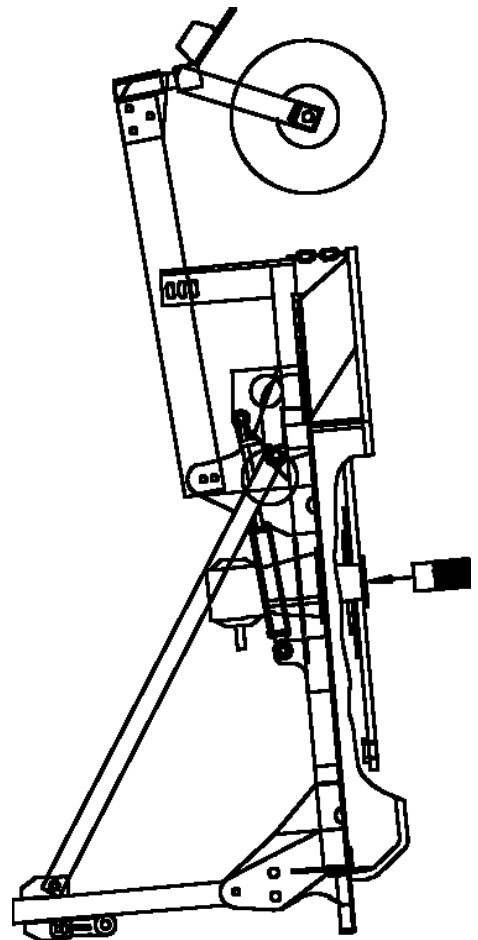

BLADE BAR INSTALLATION PROCEDURE FOR THE BROWN TREE CUTTER

BLADE BAR INSTALLATION

NOTE: Prior to blade bar installation, ensure that the output shaft and the hub are clean and dry. Apply **anti-seize compound** to the hub or shaft.

- Step 1 - Remove the bolts from the A-frame braces at the A-frame and lower the braces to the cutter deck.
- Step 2 - Loosen, but do not remove the A-frame attaching bolts and lower the A-frame down against the input shaft.
- Step 3 - Using a suitable lift, turn the cutter upside down, being careful not to damage the gear box. The cutter should rest on the tailwheel assembly and the A-frame mounting plates.
- Step 4 - Be sure that the output shaft is clean, coat splines with copper antiseize. Be sure the splines of the hub in the blade bar are clean.
- Step 5 - Carefully take the cutter bar and position it over the splined output shaft making sure the splines are aligned. The bar should go down approximately 2 3/4" on the shaft.
- Step 6 - Install the nut on the output shaft and tighten to approximately 300 lb-ft with a 2 9/16" socket part number T5-054AS.
- Step 7 - Take an 8 to 12 lb. sledge hammer and hit the bottom of the cutter bar several times, approximately 6 inches from the hub, in a circular pattern around the hub.
- Step 8 - Tighten the bar again to approximately 2200 lb-ft.
- Step 9 - Repeat Step 6, hitting the bar with hammer.
- Step 10 Retighten the nut to approximately 2200 lb-ft torque. Remove the wrench for the nut and check the location of the cotter pin slot and the hole in the shaft. If the hole and slot are not aligned, continue tightening the nut until the hole and slot are aligned and insert the cotter pin. If after tightening the nut to a maximum of 3800 lb-ft of torque the hole and slot are still not aligned, install a different nut and repeat the tightening procedure. Never loosen the nut to align for cotter pin installation.

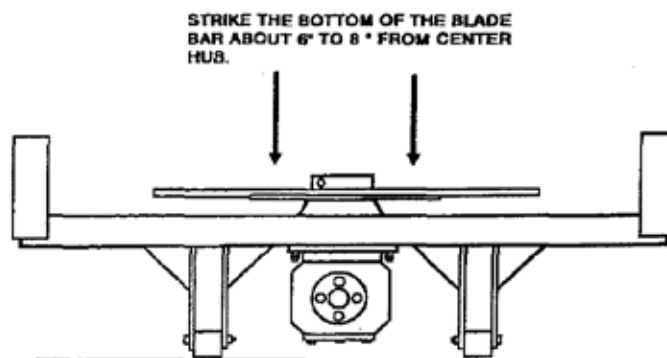

BLADE BAR TIGHTENING PROCEDURE FOR ALL BROWN TREE CUTTERS

On start up of a tree cutter, or after the blade bar has been removed for any reason, the following steps must be followed:

AFTER THE FIRST HOUR OF OPERATION:

Shut the unit down, lift the cutter deck approximately two feet above the ground. Place jack stands or blocks under the blade bar. Then lower the cutter onto the stands to support the entire unit's weight on the blade bar allowing the output shaft to seat as deep as possible into the hub of the blade bar. (See diagram), do not rely on the tractor's lift system to hold the cutter up during any maintenance procedure. To ensure the hub is seated properly onto the shaft of the gear box, strike the blade bar several times with a large hammer.

Only at this time can you properly tighten the blade bar nut. Without the weight of the blade bar being supported by jacks or stands the nut cannot tighten the blade bar securely.

Using a 6 point 2 9/16" socket, part # T5-054AS and appropriate torque wrench, tighten the blade bar nut to 2200 ft lbs. torque. Continue to tighten until the cotter pin slot is aligned. Insert the cotter pin.



CAUTION: Never loosen a blade bar nut to align the cotter pin hole and slot. Always continue tightening the nut until they are aligned, tightening up to the maximum allowable torque of 3800 lb-ft. If alignment is still not achieved, replace the nut with a new one and repeat the tightening procedure.

After the nut is properly tightened **MAKE SURE** you replace the proper size cotter pin in the shaft. **THIS PROCEDURE WILL NEED TO BE REPEATED EVERY HOUR UNTIL THE NUT IS FOUND TO BE SECURELY TIGHTENED AT THE END OF THE 2ND OR 3RD HOURLY CHECK, THEN IT WILL NEED TO BE REPEATED ONCE A WEEK AS PREVENTATIVE MAINTENANCE.**

THE BLADE BAR SHOULD BE CHECKED DAILY BY INSERTING A LONG PRY BAR BETWEEN THE DECK FRAME AND BLADE BAR. USING A PRYING MOTION, VISUALLY CHECK FOR ANY LOOSE VERTICAL MOTION. IF ANY LOOSE MOTION IS DETECTED, FOLLOW THE BLADE BAR TIGHTENING PROCEDURE. IF THE BLADE BAR WILL NOT REMAIN TIGHT, DISASSEMBLE THE UNIT AND CHECK HUB AND SHAFT FOR WEAR. REPLACE AS NECESSARY.

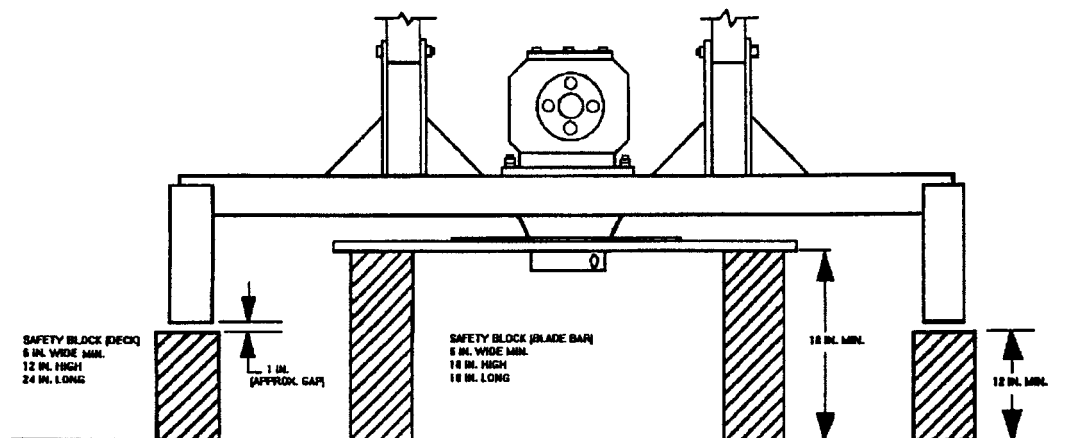

Troubleshooting

Problem	Possible Cause(s)	Possible Solution(s)
Excessive vibration	<ol style="list-style-type: none"> 1. Loose gearbox bolts 2. Loose blade bar and/or blade bolts 3. Blades are not freely swinging 4. Broken, bent, or warped blades 5. Blade bar not seated properly on shaft 	<ol style="list-style-type: none"> 1. Tighten bolts 2. Tighten blade bar nut or blade bolt nuts 3. Clear blade of obstruction 4. Replace set of blades and bolts, install T5-165S shim between blade bar and bolt. 5. Remove blade bar; clean hub and shaft; reseal
Excessive clutch slippage	<ol style="list-style-type: none"> 1. Worn clutch linings or plates 2. Oil on lining 3. Glazed friction lining 4. Excessive torque on clutch 5. Dull blades 	<ol style="list-style-type: none"> 1. Repair clutch 2. Replace linings 3. Clean with emory cloth 4. Reduce ground speed, material intake, or tractor size 5. Sharpen or replace blades
Overheating gearbox	<ol style="list-style-type: none"> 1. Insufficient lubricant level 2. Improper lubricant 3. Debris build-up around gearbox 4. Bearing or gears set improperly 	<ol style="list-style-type: none"> 1. Fill to full level 2. Replace with correct lubricant 3. Remove debris 4. Consult dealer
Noisy gearbox	<ol style="list-style-type: none"> 1. Rough gears 2. Worn bearing 	<ol style="list-style-type: none"> 1. Run for a short break-in period or replace gears 2. Replace bearing
Leaking gearbox	<ol style="list-style-type: none"> 1. Damaged oil seal 2. Bent shaft 3. Oil seal installed incorrectly 4. Oil level too high 5. Shaft rough or pitted in oil seal area 6. Shaft bore worn in casting 7. Damaged gasket 8. Loose bolts 	<ol style="list-style-type: none"> 1. Replace seal 2. Replace seal and shaft 3. Replace seal 4. Drain oil to proper level 5. Replace shaft 6. Replace casting or gearbox 7. Replace gasket 8. Tighten bolts.
Short blade life	<ol style="list-style-type: none"> 1. Cutting too low 2. Cutting in sandy or rocky conditions 3. Inadequate blades 	<ol style="list-style-type: none"> 1. Increase cutting height 2. Increase cutting height 3. Replace with Brown blades
Not cutting clean	<ol style="list-style-type: none"> 1. Dull blades 2. Insufficient PTO speed 3. Cutter deck not level 4. Ground speed too fast 5. Blades are not freely swinging 	<ol style="list-style-type: none"> 1. Sharpen or replace blades 2. Use correct PTO speed 3. Adjust cutter deck 4. Reduce ground speed 5. Clear blade of obstruction

NOTE: Most common problems are caused by DULL BLADES!
Continued use of this equipment with dull blades will shorten the life of the unit.

Specifications

Model	TCO-2500 TCO-2505	TCO-2600 TCO-2605	TCF-2600 TCF-2605	TCO-2620 TCO-2625	TCF-2620 TCF-2625
PTO Speed	1000 RPM 540 RPM	1000 RPM 540 RPM	1000 RPM 540 RPM	1000 RPM 540 RPM	1000 RPM 540 RPM
Cutting Width	60"	72"	72"	72"	72"
Gearbox	145 HP	145 HP	145 HP	240 HP 165 HP	240 HP 165 HP
Deck Const.	3/16"	1/4"	1/4"	1/4"	1/4"
Deck Width	69"	81"	81"	81"	81"
Weight	1,700 lbs	2,200 lbs	2,500 lbs	2,350 lbs	2,600 lbs
Material Size	6" max	6" max	6" max	8" max	8" max
Gearbox Oil Capacity in Pints	8	8	8	11	11

Replacement Parts

Deck Assembly - All Models

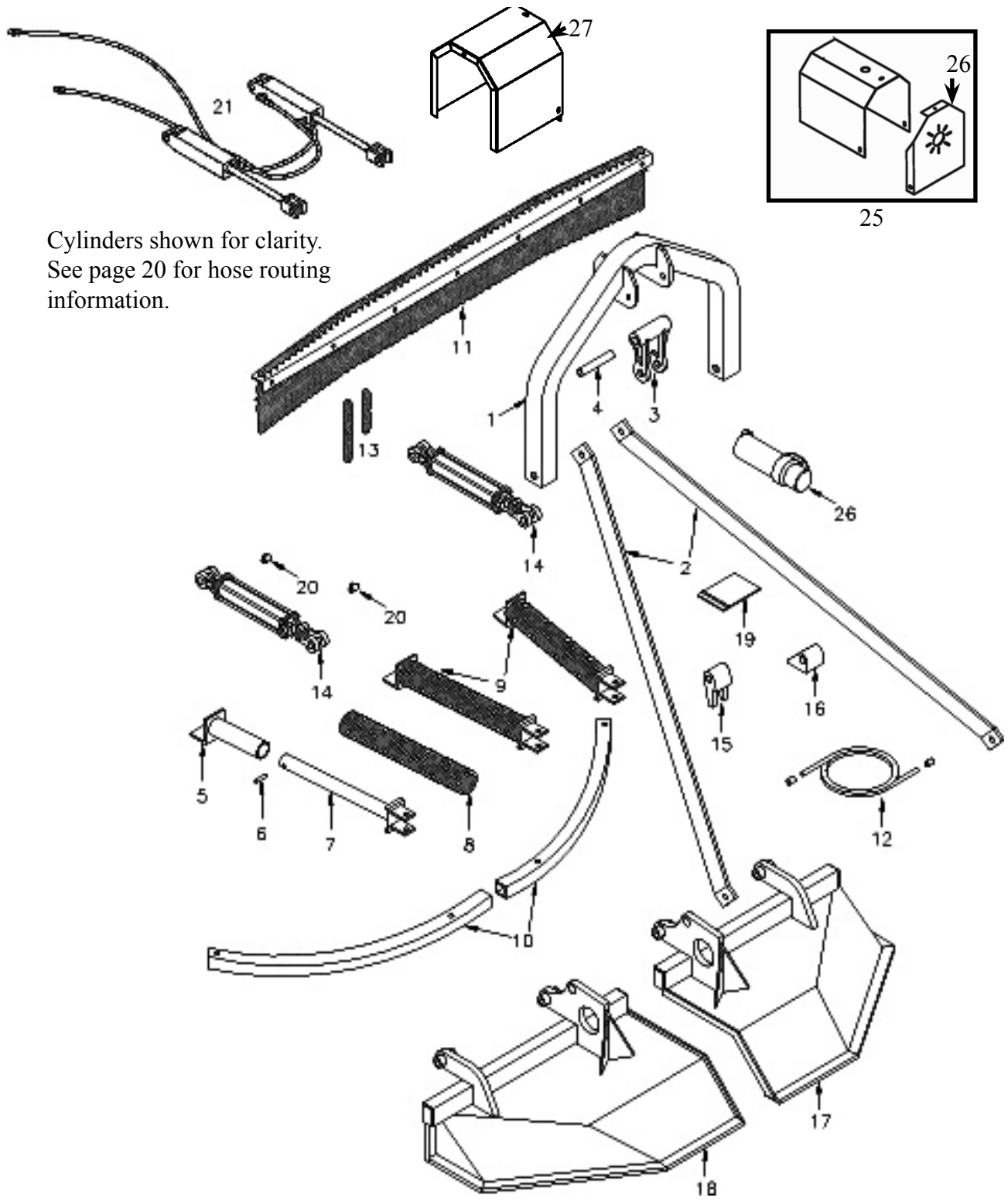

Cylinders shown for clarity.
See page 20 for hose routing
information.

Replacement Parts

Deck Assembly - All Models (continued)

Ref. No.	Part No.	Qty	Description
1	BM-51	1	A-frame
2	TC2-015	2	A-frame brace - 5' models (2 req.)
	TC2-014		A-frame brace - 6' open deck models (2 req.)
	TC2-024		A-frame brace - 6' folding deck models (2 req.)
3	TC2-003	1	Flex toggle
4	TC2-016	1	Spacer
5	TC2-017	2	Outer spring guide - open deck models (2 req.)
6	61-D	2	Roll pin - open deck models (2 req.)
7	TC2-018	2	Inner spring guide - open deck models (2 req.)
8	TC-160	2	Spring - open deck models (2 req.)
9	TC2-019	2	Spring/guide assembly - open deck models (2 req.)
10	TC2-020A	2	Pressure bar - 5' open deck models (2 req.)
	TC2-020		Pressure bar - 6' open deck models (2 req.)
11	TCO-5SC	1	Safety chain curtain assembly - 5' models
	TCO-6SC		Safety chain curtain assembly - 6' models
12	TC2-011	1	Cable (w/ clamps)
13	TC2-009		5/16" Chain - 5 link
14	TC2-001	2	Hydraulic cylinder - folding deck models (2 req.)
15	TC2-025	6	Hinge, vertical mount - folding deck models (6 req.)
16	TC2-026	2	Hinge, horizontal mount - folding deck models (2 req.)
17	TC2-021	1	Folding deck - right
18	TC2-022	1	Folding deck - left
19	TC2-023	1	Access plate (w/ lynch pin)
20	TC2-004B	2	Tee swivel - folding deck models (2 req.)
21	TC2-004	1	Hydraulic hose kit assembly, complete - folding deck models - cylinders sold separately.
22	500-22	1	Top hitch pin - Cat. II
23	TC-126	2	Lower hitch pin - Cat. II
24	TC-126A	4	Lynch pin
Not Shown	TC2-027	4	Wear bushing - folding deck models (1-1/4" x 1" x 1")
25	232-0028	1	Drive Shaft Cover Assembly
26	700-232-0030	1	Plate, Drive Shaft Guard
27	700-232-0031	1	Drive Shaft Guard
Not Shown	HC56C16Z	3	Bolt, 3/8"-16 x 1 HCS Grade 5 - for Bell Shield
Not Shown	LOC38Z	3	3/8" Lock Washer - for Bell Shield

Replacement Parts

145 HP Gearbox

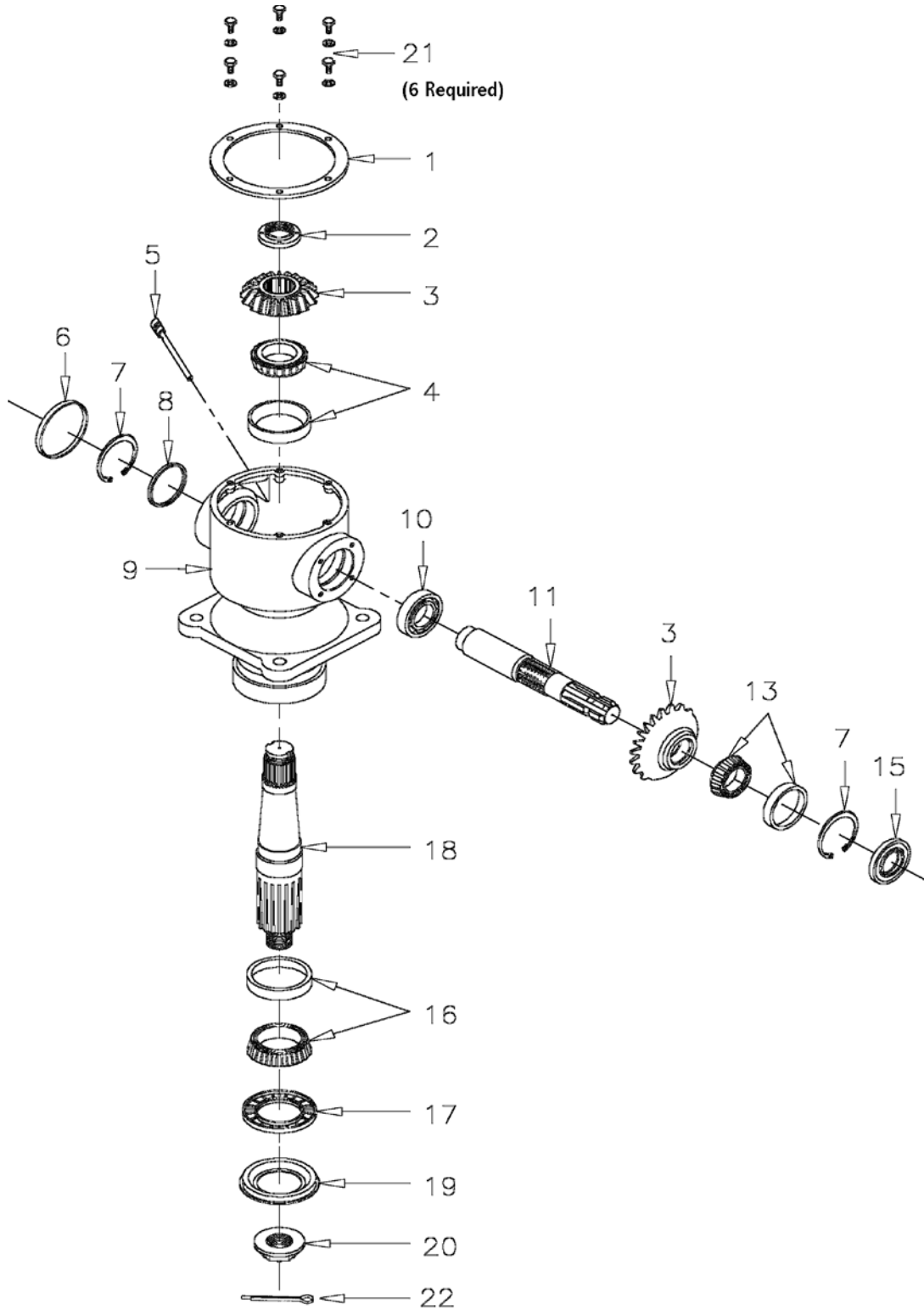

Replacement Parts

145 HP Gearbox (continued)

We have a section on our website: www.brownmfcorp.com, under Maintenance Bulletins, that is a detailed procedure for the disassembly and reassembly of this gearbox.

Ref. No.	Part No.	Description
1	BM-100	Cover plate
2	BM-110	Top output shaft nut
3	BM-104 BM-113	Gear set - 1000 RPM Gear set - 540 RPM
4	BM-111	Bearing set, top output shaft
5	T5-068	Vent plug (w/ dipstick)
6	BM-107	Rear seal plug
7	BM-103	Lock ring (2 req.)
8	BM-108	Shim Kit, 1 each of 0.2MM - 0.25MM - 0.3MM - 0.4MM Shims
9	BM-105	Gearbox housing
10	BM-109	Bearing set, rear input shaft
11	BM-102 BM-115	Input shaft - 1-3/4" x 6 spline Input shaft - 1-3/4" x 20 spline
13	T5-060	Bearing set, front input shaft
15	BM-101	Seal, input
16	BM-106 235-0032	Bearing set, bottom output shaft (32014) must specify when ordering. (old style) Bearing Set, bottom output shaft (33014) must specify when ordering.
17	T5-065	Seal, output
18	BM-112	Output shaft, tapered (must purchase w/ 235-0032 bearing)
19	T5-048	Output seal guard
20	T5-054A	Nut, flanged, castellated
21	T5-050	Bolt, Hex Head (M10 x 20) for Top Plate
Not shown	T5-074T-25	Oil plug
22	T5-052	Cotter pin, 5/16" x 3"
Not shown	T5-LUBE	85-140 gearbox lubricant (1 QT)

Replacement Parts

240/165 HP Gearbox

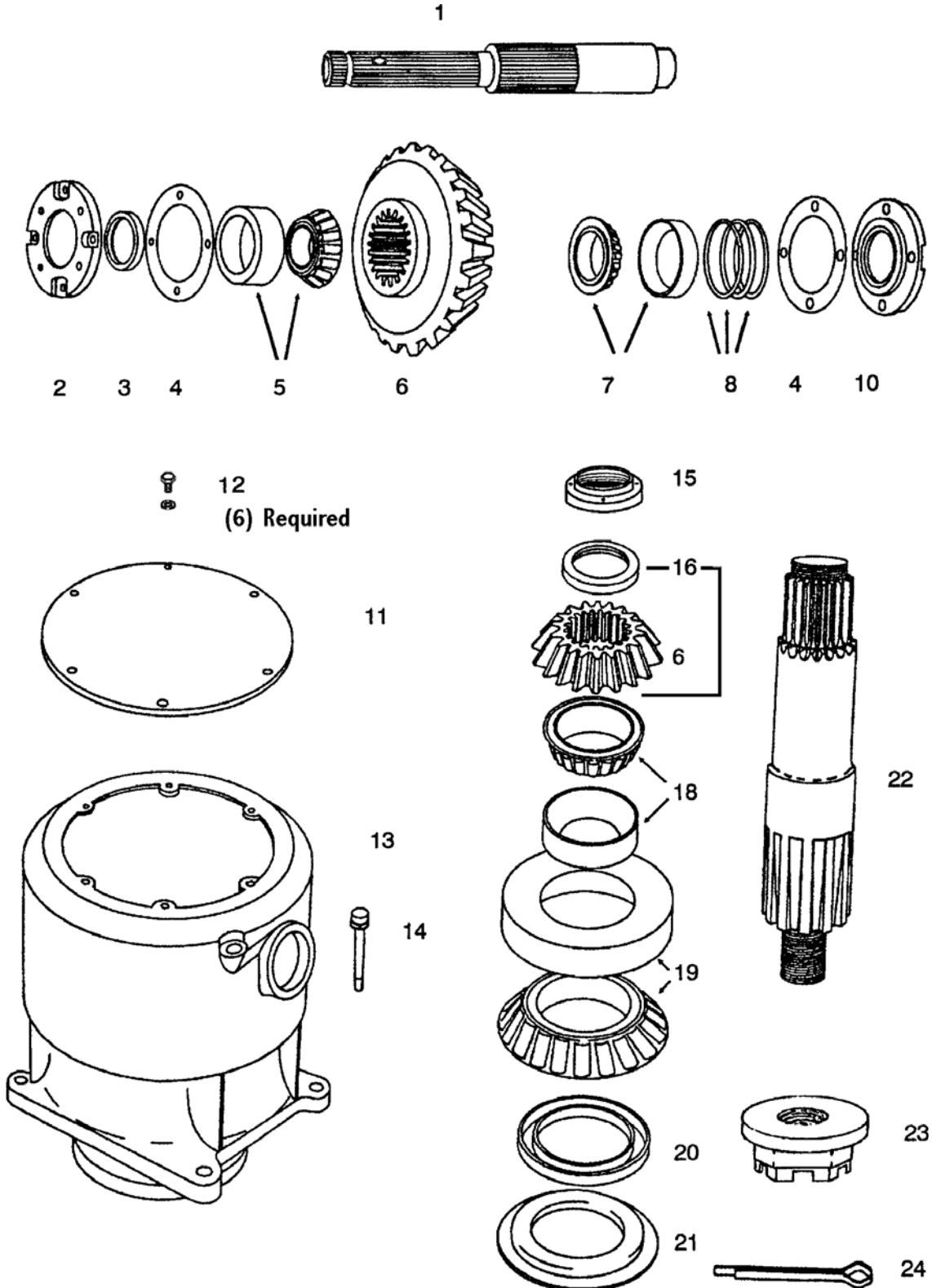

We have a section on our website: www.brownmfcorp.com, under Maintenance Bulletins, that is a detailed procedure for the disassembly and reassembly of this gearbox.

Replacement Parts

240/165 HP Gearbox (continued)

Ref. No.	Part No.	Description
1	T5-039 T5-039-20	Shaft, input - 1-3/4" x 6 spline Shaft, input - 1-3/4" x 20 spline
2	T5-036	Plate, front input
3	T5-066	Seal, input
4	T5-047	Gasket, input
5	T5-064	Bearing set, front input
6	T5-069A T5-076S	Gear set - 540 RPM Gear set - 1000 RPM
7	T5-060	Bearing set, rear input
8	BM-108	Shim Kit, 1 each of 0.2MM - 0.25MM - 0.3MM - 0.4MM Shims
10	T5-037	Plate, rear input
11	T5-035	Plate, top
12	T5-050	Bolt, Hex Head (M10 x 20) for Top Plate
13	T5-038	Housing, gearbox
14	T5-068	Plug, vent/dip
15	T5-044A	Nut, output shaft, top
16	T5-045 T5-076A	Spacer, output, 540 RPM (above gear) Spacer, output, 1000 RPM (below gear)
18	T5-061	Bearing set, upper output
19	T5-062	Bearing set, lower output
20	T5-065	Seal, output
21	T5-048	Protector, seal
22	T5-040	Shaft, output
23	T5-054A	Nut, flanged, castellated
24	T5-052	Pin, cotter
Not shown	T5-074	Gearbox - 540 RPM
Not shown	T5-074B	Gearbox - 1000 RPM
Not shown	T5-051	Bolt, front & rear input plate
Not shown	TC2-002	Bolt, Grade 8, sq. head, 3/4" x 3-1/2"
Not shown	T5-LUBE	Gearbox oil (1 QT)
Not shown	LT-120-1	Vent, breather, top plate

We have a section on our website: www.brownmfcorp.com, under Maintenance Bulletins, that is a detailed procedure for the disassembly and reassembly of this gearbox.

Replacement Parts

145 HP Blade Carrier Assembly

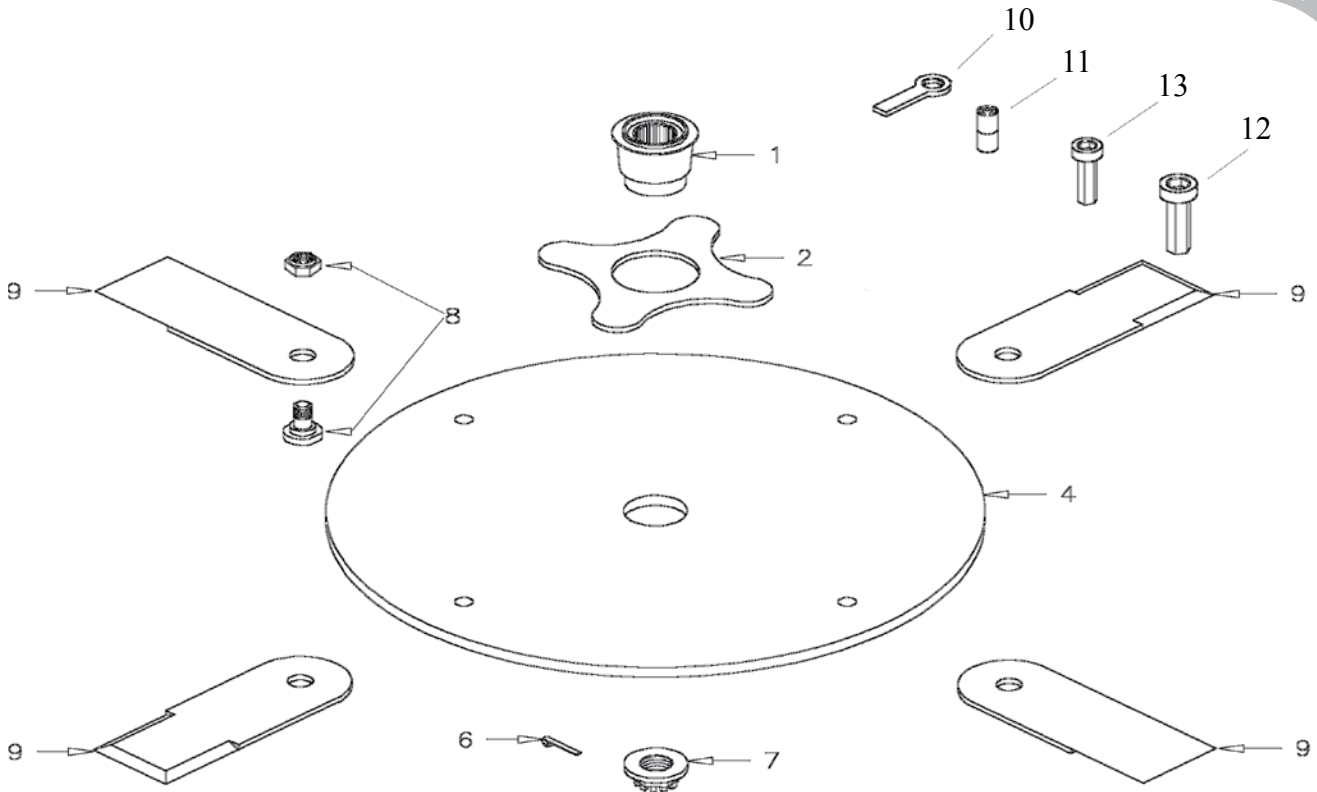

Ref. No.	Part No.	Description
1	235-4500	Blade carrier hub (<i>sold only with item 4</i>)
2	T5-078	Blade carrier star plate (<i>sold only with item 4</i>)
4	TC2-145-5 TC2-145	Blade carrier assembly (<i>includes items 1, 2, 4, 5</i>) - 5' models Blade carrier assembly (<i>includes items 1, 2, 4, 5</i>) - 6' models
6	T5-052	Cotter pin
7	T5-054A	Nut, Splined w/ flange (Castellated) Blade Carrier
8	TC-133KL TC2-005-KIT	Blade bolt kit - 5' models (matched bolt & nut) right handed threads Blade bolt kit - 6' models (matched bolt & nut) left handed threads
9	UK-905 UK-120	Blade - 5' models Blade - 6' models
10	TC-Wrench	Socket wrench
11	T-2600-001	Removal tool
12	TC2-006S	120/145 Blade bolt socket
13	T5-054AS	145/165/240 Blade bar socket
NS	TC-133S	Blade Bolt Shim, (used, if blade is binding under blade bar)
NS	TC2-005S	Blade Bolt Shim, (used, if blade is binding under blade bar)

Replacement Parts

240/165 HP Blade Carrier Assembly

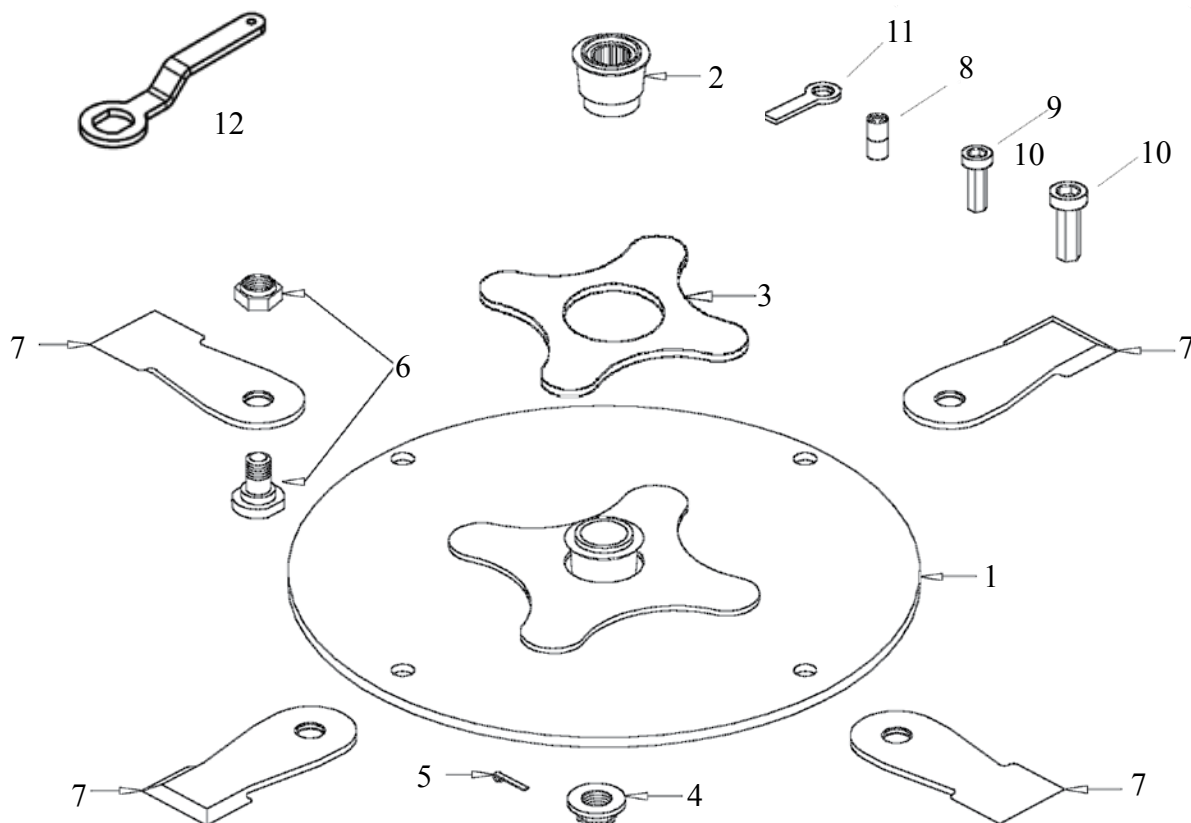

Ref. No.	Part No.	Description
1	T5-000A	Blade bar assembly
2	235-4500	Blade bar hub (<i>sold only with Item 1</i>)
3	T5-078A	Reinforcement plate, large (<i>sold only with Item 1</i>)
4	T5-054A	Nut, Splined w/ flange (Castellated) Blade Carrier
5	T5-052	Cotter pin
6	T5-165NB	Blade bolt w/ nut sold in kits only (4 req.) Right Hand Threads
7	UK-165NB	Blade, round back (4 req.) 2.75" hole, Blade angle, two up, two down!
8	T-2600-001	Removal tool
9	T5-004BS	165/240 Blade bolt socket
10	T5-054AS	145/165/240 Blade bar socket
11	TC-Wrench	Socket wrench
NS	T5-165S	Blade Bolt Shim, (used, if blade is binding under blade bar)
12	NB-133 WRENCH	Blade Bolt Head Wrench for TC-133KL Bolts
12	TC-120 WRENCH	Blade Bolt Head Wrench for TC2-005-KIT Bolts
12	TC-165B WRENCH	Blade Bolt Head Wrench for T5-165NB Bolts

Replacement Parts

Tail wheel Assembly - All Models - Please verify the WIDTH of your tree cutter when ordering replacement tail wheel parts! These items are WIDTH specific. The width is the second number in your model number i.e. TCO-2620C.

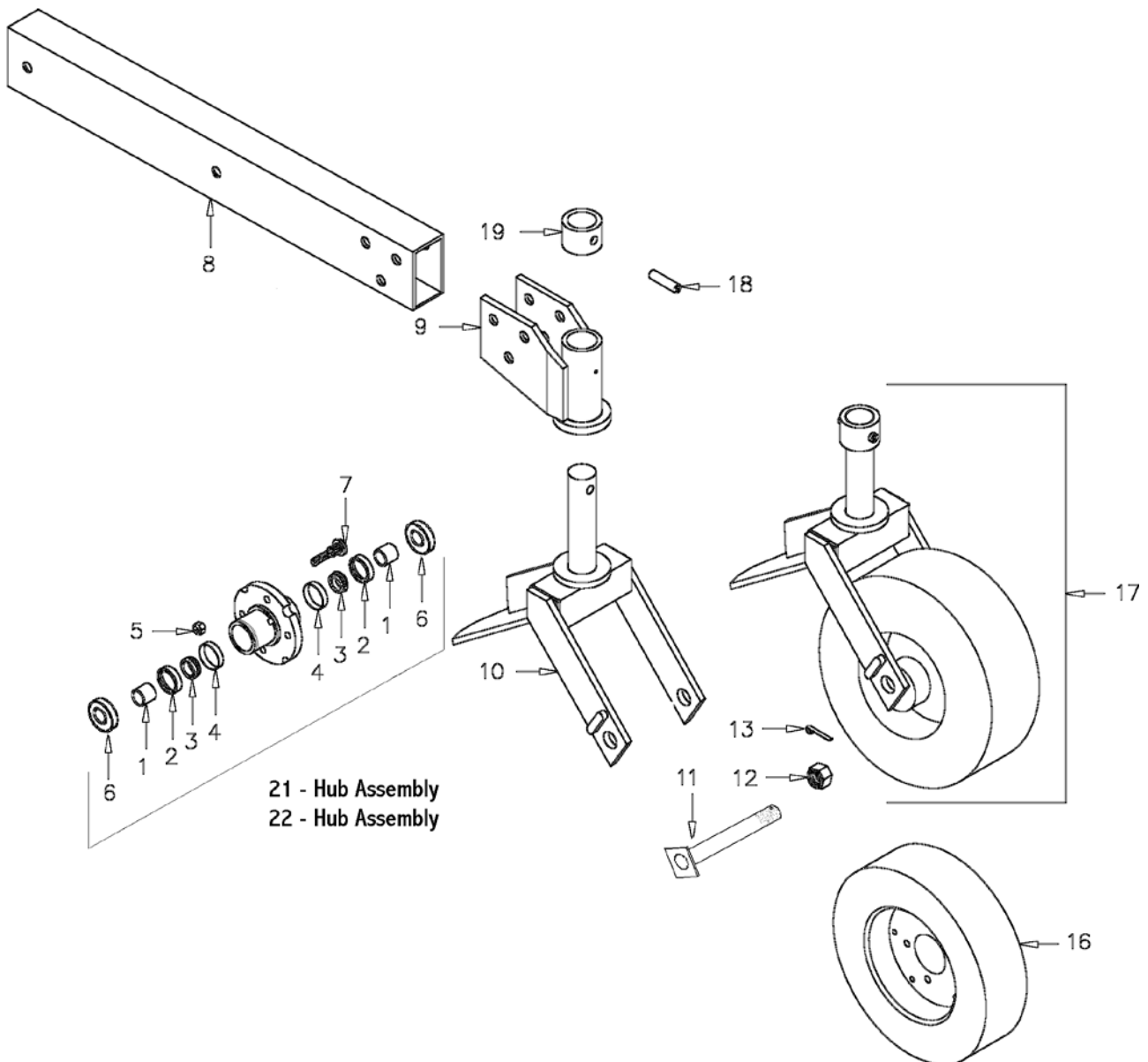

Replacement Parts

Tailwheel Assembly - All Models (continued)

Ref. No.	Part No.	Description
1	232-0087 232-6020	Spacer - (2 req.)all 6' models Spacer - (2 req.)all 5' models
2	TC-402 TC-108	Seal - (2 req.) all 6' models Seal - (2 req.) all 5' models
3	TC-401 TC-109	Bearing - (2 req.)all 6' models Bearing - (2 req.)all 5' models
4	TC-404 TC-110	Bearing cup - (2 req.)all 6' models Bearing cup - (2 req.)all 5' models
5	TC-407	Lug nut - all models
6	232-0085 232-6010	Protector, Seal - All 6' Models Protector, Seal - All 5' Models
NS	FGR1428ST	Grease Fitting, 1/4/28 Self Tapping Straight for 232-6000
7	TC-406 TC-001	Lug stud - all 6' models Lug bolt - all 5' models
8	TC-416 TC-417	Tailwheel arm - 6' models Tailwheel arm - 5' models
9	TC-119 TC-119X	Fork holder - 6' models Fork holder - 5' models
10	TC-105 TC-105A	Fork - 5' & 6' models Fork w/ collar & roll pin - 5' & 6' models
11	TC-106	Axle - all models
12	TC-114	Axle nut - all models
13	TC-115	Cotter pin - all models
16	TC-414 TC-113XA	Tire & wheel assembly - 6' models Tire & wheel assembly - 5' models
17	TC-415 TC-101X	Tailwheel assembly, complete - 6' models Tailwheel assembly, complete - 5' models
18	TC-012	Roll pin - all models
19	TC-011	Fork collar - all models
21	TC-400A	Hub assembly, complete - all 6' models
22	232-6000	Hub assembly, complete - all 5' models

Drive Shaft

Used on Tree Cutters with a identifier of "D" as the 5th character in the serial number,
EXAMPLE: T620 "D" ????

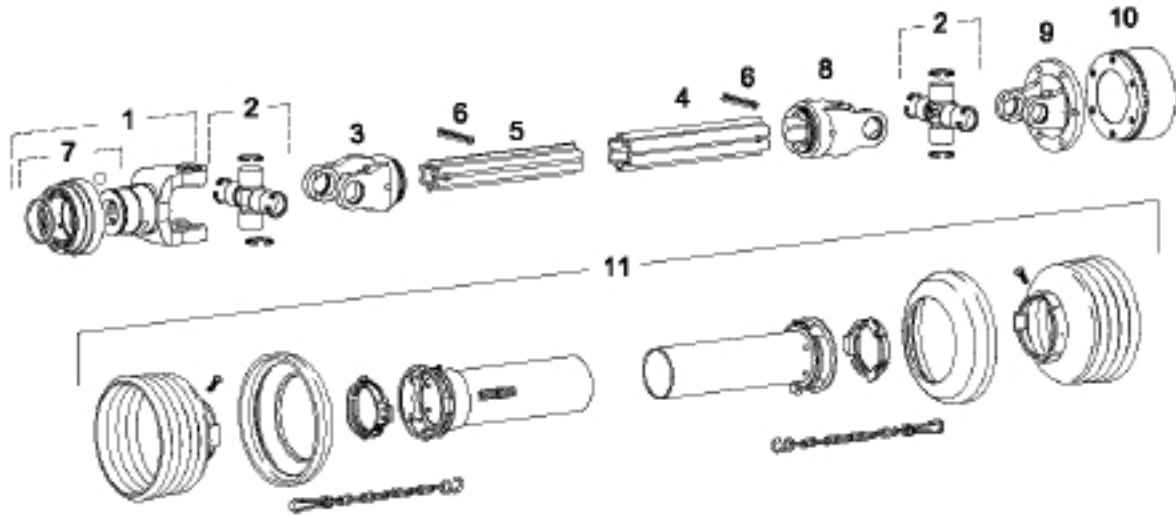

Ref. No.	Part No.	Qty.	Description
1	T5-W1 T5-W36	1	Yoke 1 3/8" - 21 Spline Tractor End 1000 RPM Yoke 1 3/8" - 6 Spline Tractor End 540 RPM
2	T5-W4	2	Cross and Bearing Kit
3	T5-W5	1	Inboard Yoke, Inner Tube
4	236-2005	1	Outer Tube, 6' Models
5	T5-WS3A	1	Inner Tube, 6 Foot Models
6	236-0612	2	Roll Pin, 10 x 90
7	T5-W2 T5-W2A	1 1	Quick Disconnect Kit 1 3/8in Quick Disconnect Kit 1 3/4in
8	T5-W7	1	Inboard Yoke, Outer Tube
9	236-2010	1	Flange Yoke, (Same as Item 2, next page)
10	236-2001 236-2101	1 1	Overrunning, clutch assembly 1-3/4 z20 spline - 1000 RPM Overrunning, clutch assembly 1-3/4 z6 spline - 540 RPM
11	T5-W42	1	Shield Assembly, Complete (Parts Not sold seperately)
Assembly	236-2100	1	Drive shaft assy. complete 1-3/8" z 6 spline 540 RPM (No Clutch)
Assembly	236-2000	1	Drive shaft assy. complete 1-3/8" z 21 spline 1000 RPM (No Clutch)

Slip Clutches 236-2001 and 236-2101

Used on Tree Cutters with a identifier of "D" as the 5th character in the serial number, EXAMPLE: T620 "D" ????

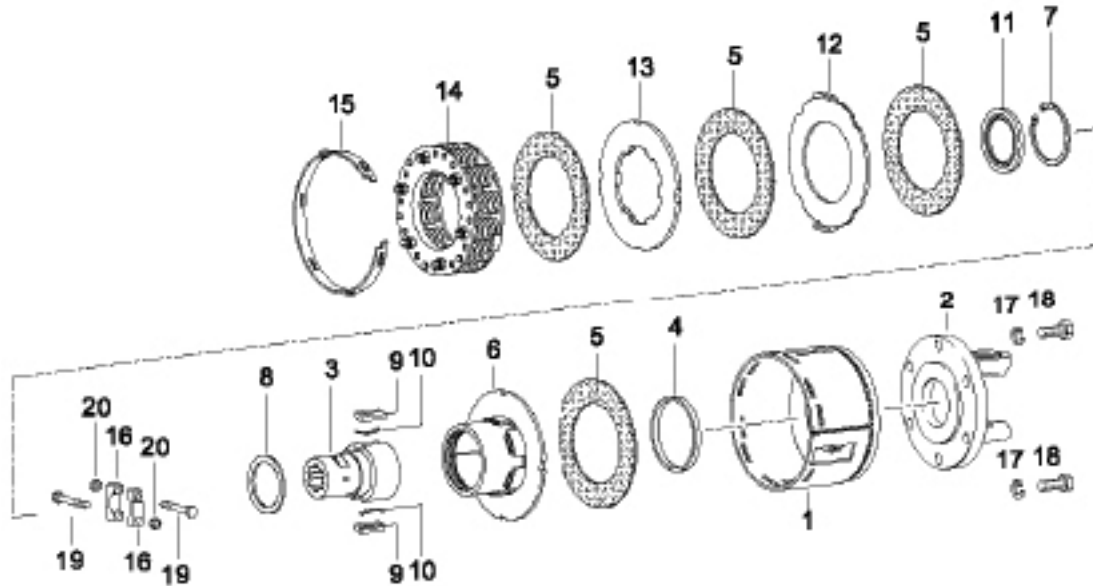

Ref. No.	Part No.	Qty.	Description
1	236-2099	1	Clutch Housing
2	236-2010	1	Yoke (Bolt On)
3	T5-W30	1	Hub, 1 3/4" x 6 Spline 540 RPM
	T5-W43	1	Hub, 1 3/4" x 20 Spline 1000 RPM
4	T5-W19	1	Centering Ring
5	T5-W20	4	Friction Lining
6	T5-W21	1	Drive Plate
7	T5-W22	1	Lock Ring
8	T5-W23	1	Supporting Ring
9	T5-W25	2	Key
10	T5-W24	2	Leaf Spring
11	T5-W32	1	Sealing Ring
12	T5-W26	1	Drive Plate (Outer)
13	T5-W27	1	Drive Plate (Inner)
14	T5-W49	1	Spring Pack
15	T5-W29	1	Setting Ring
16	T5-W33	2	Clamp Bridge
17	MLW12Z	6	Lock Washer M12
18	MCS12C30Z88	6	M12 x 1.75 x 30 x 8.8GR Bolt
19	T5-W35	2	Bolt M16 x 110mm for T5-W33
20	T5-W34	2	M16 Nut for T5-W33

TORQUE SETTING FOR OVER RUNNING / SLIP CLUTCH

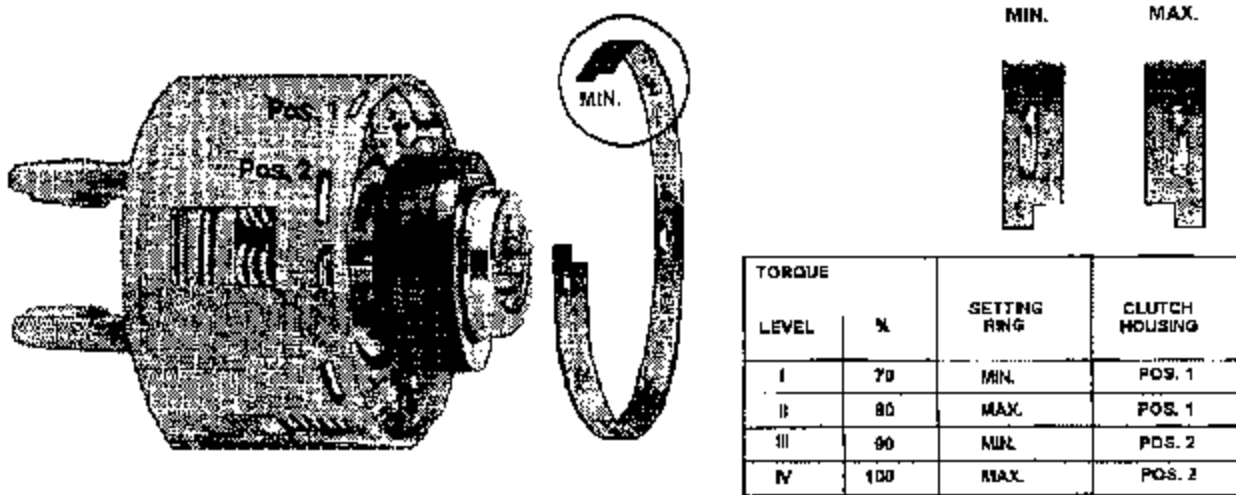

The torque setting can be modified with the aid of the setting ring and two alternative location slots in the clutch housing.

1. The setting ring provides for a MIN. position and a MAX. position.
2. The clutch housing incorporates two location positions for the setting ring, (1 and 2), which are located at different levels.
3. To adjust the clutch to a higher or lower setting, tighten the 6 (six), 13mm lock nuts with a deep well socket until the pressure is removed from the setting ring. The tightening of these bolts removes the spring pressure from the clutch. The nuts will need to be tightened sufficiently to allow a small amount of play between the clutch housing and the spring pack assembly. (Tighten lock nut until about 5/8" of the bolt protrudes through the nut).
4. With the spring pressure removed from the clutch, insert a chisel through the slot the setting ring is locked into. Strike the chisel against the setting ring dislocating the ring from the slot. Continue this process around the clutch until the setting ring is free from the clutch.
5. Refer to the above diagram for proper ring position and slot position before reinstalling the setting ring.

NOTE: IT IS RECOMMENDED TO INSPECT THE CLUTCH LININGS FOR WEAR AND POSSIBLE REPLACEMENT AT THIS TIME.

6. With the setting ring on the proper side and seated into the proper slot position. Loosen the 6 lock nuts to restore spring pressure to the clutch.

NOTE: Back the lock nut to the end of the spring bolts to insure all possible spring pressure is applied to the clutch.

Notes

236-2500 Drive Shaft with Mechanical Slip Clutch

Used on Tree Cutters with a identifier of "D" as the 5th character in the serial number,
EXAMPLE: T620 "D" ????

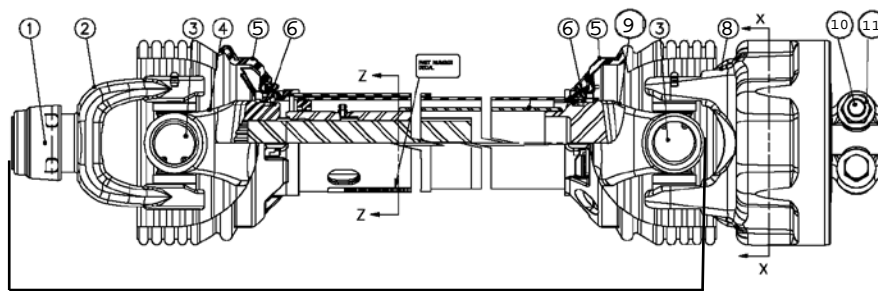

7

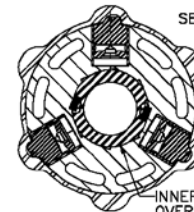

SECTION X-X

INNER HUB CLOCKWISE
OVERRUNNING ROTATION
AS VIEWED FROM END



1 3/8-21 SPLINE
PER ASAE S203.14



PHASE
SECTION Z-Z

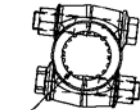

1.75-20 SPLINE

Ref. No.	Part No.	Qty.	Description
Assembly	236-2500	1	1 3/8" - 21 spline X 1 3/4" - 20 spline Driveshaft with Clutch
1	236-2531	1	Slide Lock Repair Kit
2	236-2542	1	Safety Slide Lock, 1 3/8-21 Spline
3	236-2553	2	Cross and Bearing Kit
4	236-2500-1	1	Yoke & Shaft (1.89-20 Spline) Tractor End
5	236-2528	1	Full Safety Guard
6	236-2571	2	Guard Repair Kit
7	236-2515	1	1 3/8" - 21 spline x yoke Driveshaft, NO Clutch
8	236-2525	1	Mechanical Clutch 1 3/4" -20 Spline
9	236-2500-2	1	Yoke & Shaft (1.89-20 Spline) Implement End
10	BFD16X80	2	Metric Head Flanged Bolt M16x2.0x80 plain - Wrench Size 21mm
11	NNF16CLZ	2	M16x2.0 - Wrench Size 24mm

Mechanical Slip Clutch 236-2525

Used on Tree Cutters with a identifier of "D" as the 5th character in the serial number, EXAMPLE: T620 "D" ????

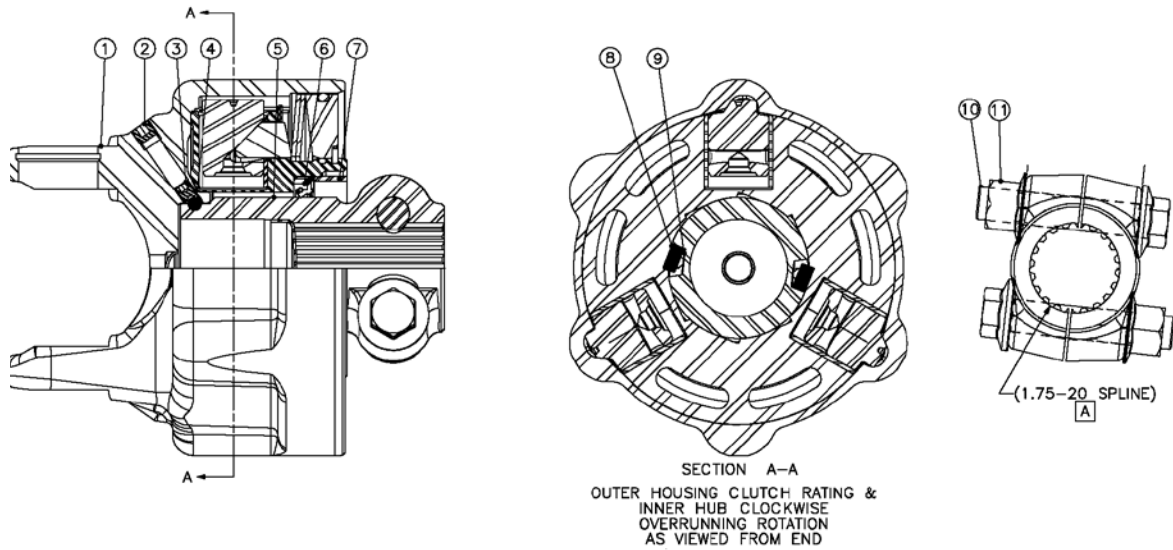

Ref. No.	Part No.	Qty.	Description
Assembly	236-2525	1	1 3/4" - 20 Spline Mechanical Clutch
			This unit is not field serviceable, please contact Brown Manufacturing for replacement.
10	BFD16X80	2	Metric Head Flanged Bolt M16x2.0x80 plain - Wrench Size 21mm
11	NNF16CLZ	2	M16x2.0 - Wrench Size 24mm

Notes

Revisions

Date	Page	Change Made
7/20/2016	53	Added Bolt Head Wrenches for new bolts, Items 12.
12/8/2016	46-47	Added Items 25 - 27, Drive Shaft Shield Components
1/25/2017	4-5	Changed Warranty Details
1/27/2017	60-61	Added Mechanical Clutch and Drive Shaft
4/10/2017	52-53	Changed Hub to 235-4500
2/2/2018	60-61	Added Components for shaft and clutch

**Thank You,
for purchasing a Brown Tree Cutter.**

From Serial Number * * * * D 0 0 0 1

Brown Tree Cutters
Version 7.3.0
October 2018



6001 E. Hwy 27 - Ozark, AL 36360
334.795.6603 - Fax: 334.795.3029